

RDQ Series

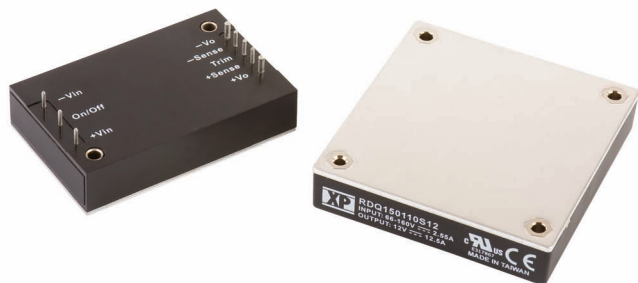

- 110 VDC Input for Rail Applications
- Up to 92% Efficiency
- Quarter and Half Brick Packages
- -40 °C to +100 °C Operating Temperature
- Baseplate-cooled
- Remote On/Off & Remote Sense
- 3 Year Warranty

Specification

Input

Input Voltage Range	• 66-160 VDC
Input Current	• See table
Idle Current	• 50 mA
Input Filter	• Pi network (see note 3)
Undervoltage Lockout	• Turn on 62.0 V, turn off 56.0 V
Input Surge	• 180 VDC for 100 ms

Output

Output Voltage Trim	• $\pm 10\%$, see application notes
Initial Set Accuracy	• $\pm 1.5\%$ max
Line Regulation	• $\pm 0.2\%$ max measured from high line to low line
Load Regulation	• $\pm 0.2\%$ max measured from 0-100% load
Start Up Time	• 60 ms typical
Transient Response	• 5% max deviation, recovery to within 1% in 200 μ s, 25% step load change
Ripple & Noise	• 5 V models: 100 mV pk-pk 12 V models: 150 mV max pk-pk 24 V models: 240 mV max pk-pk 20 MHz bandwidth (see note 1)
Overvoltage Protection	• 115-140%
Short Circuit Protection	• Continuous
Current Limit	• 110-180% nominal output
Thermal Shutdown	• Case temperature > 105 °C typical
Temperature Coefficient	• $\pm 0.03\%/^{\circ}\text{C}$
Remote On/Off	• Referenced to -Vin, Module on = open circuit, Module off ≤ 0.8 VDC
Remote Sense	• Compensates up to 10% of Vout nominal, total of output trim and remote sense

General

Efficiency	• See tables
Isolation Voltage	• 2250 VDC Input to Output 2250 VDC Input to Case 1500 VDC Output to Case
Isolation Resistance	• $10^7 \Omega$
Isolation Capacitance	• 1000 pF typical
Switching Frequency	• 200 kHz typical
Power Density	• RDQ100: 60 W/in ³ , RDQ150: 54 W/in ³
MTBF	• 380 kHrs typical to MIL-HDBK-217F at 25 °C, GB

Environmental

Operating Base Plate Temperature	• -40 °C to +100 °C, see derating curve
Storage Temperature	• -55 °C to +105 °C
Operating Humidity	• Up to 95% non-condensing
Cooling	• Baseplate-cooled, see derating curve
Cooling Test	• EN60068-2-1, -40 °C for 2 hours
Dry Heat	• EN60068-2-2, 70 °C for 6 hours
Damp Heat	• EN60068-2-30, 25 °C to 55 °C, 90-100% humidity, 2 cycles of 24 hours
Vibration	• EN61373, 2 Hz to 150 Hz, 5.72m/s ² on X axis, 2.55m/s ² on Y axis, 3.96m/s ² on Z axis
Shock	• EN61373, 50m/s ² half sine 30ms, 3 positive and 3 negative on X axis, 30m/s ² half sine 30ms, 3 positive and 3 negative on Y and Z axes,
Supply Variation	• EN50155, 0.7 to 1.4 Vn
Supply Interruption	• EN50155, 100% for 10 ms
Supply Change-Over	• EN50155, 0.6 Vn for 100 ms
Insulation Test	• EN50155, 500 VDC
Voltage Withstand	• EN50155, 2250 VDC
Supply Over-Voltage	• EN50155, 1.4 Vn for 0.1 s

EMC & Safety

General	• Complies with EN50121-3-2, Railway Applications - Electromagnetic Compatibility for Rolling Stock Apparatus
Emissions	• EN55011, 99 dB μ V (0.15-0.5 MHz), 93 dB μ V (0.5-30 MHz) conducted, class A radiated, EN55022 Level B conducted with external filter, see Application Notes.
ESD Immunity	• EN61000-4-2 Air ± 8 kV, contact ± 6 kV, indirect ± 6 kV, Perf Criteria A
Radiated Immunity	• EN61000-4-3 80-1000 MHz at 20 V/m, 1400-2100 MHz at 10V/m, 2100-2500 MHz at 5 V/m, Perf Criteria A
EFT/Burst	• EN61000-4-4 level 3, Perf Criteria A
Surge	• EN61000-4-5 level 2, Perf Criteria A*
Conducted Immunity	• EN61000-4-6 10 Vrms, Perf Criteria A
Safety Approval	• UL60950-1 (basic insulation)

Notes

* External TVS is required on the input. See Application Notes.

Models & Ratings

Input Voltage	Output Voltage	Output Current	Input Current		Efficiency	Maximum Capacitive Load	Model Number ⁽²⁾
			No Load	Full Load			
66-160 V	5.0 V	20.0 A	30 mA	1010 mA	90.0%	10000 µF	RDQ100110S05
	12.0 V	8.40 A	40 mA	993 mA	90.0%	8800 µF	RDQ100110S12
	24.0 V	4.20 A	60 mA	1030 mA	91.0%	1500 µF	RDQ100110S24

Notes

- Output Ripple and Noise measured with 10 µF tantalum and 1 µF ceramic capacitor across output.
- Add suffix 'N' to the model number to receive the unit with negative logic Remote On/Off.
- An external 120 µF electrolytic input capacitor is recommended to reduce input ripple voltage.

Mechanical Details

RDQ100

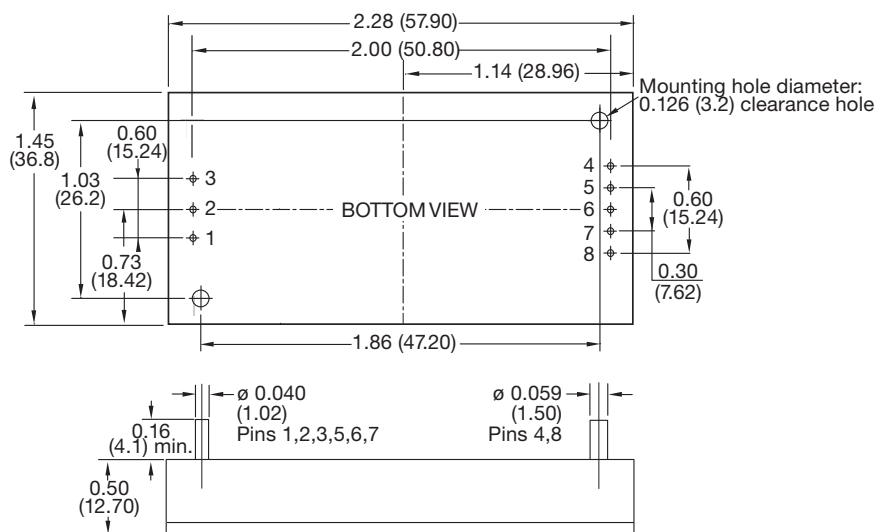

PIN CONNECTIONS	
Pin	Function
1	+Vin
2	Remote On/Off
3	-Vin
4	-Vout
5	-Sense
6	Trim
7	+Sense
8	+Vout

Notes

- Dimensions are in inches (mm)
- Tolerances: X.XX = ± 0.02 (X.X = ± 0.5)
 X.XXX = ± 0.01 (X.XX = ± 0.25)
- Weight: 0.13616 lbs (61.5 g) approx

Thermal Resistance Information (Derating Curve)

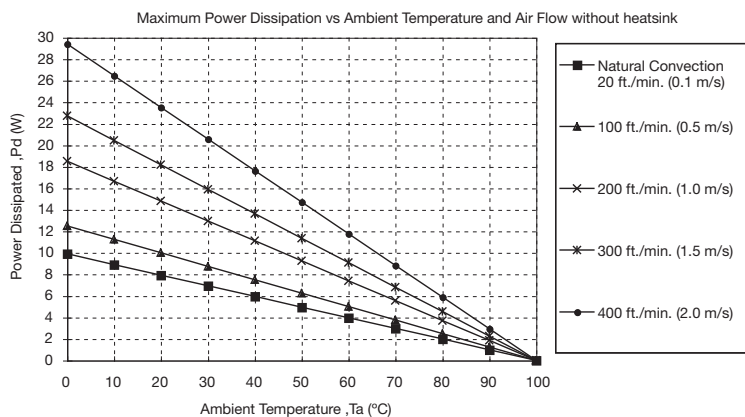

Air Flow Rate	Typical R _{ca}
Natural Convection 20 ft./min (0.1 ms)	10.1 °C/W
100 ft./min (0.5 ms)	8.0 °C/W
200 ft./min (1.0 ms)	5.4 °C/W
300 ft./min (1.5 ms)	4.4 °C/W
400 ft./min (2.0 ms)	3.4 °C/W

R_{ca} = Thermal resistance case to ambient

Models & Ratings

Input Voltage	Output Voltage	Output Current	Input Current		Efficiency	Maximum Capacitive Load	Model Number ⁽²⁾
			No Load	Full Load			
66-160 V	5.0 V	30.0 A	40 mA	1474 mA	92.5%	10000 μ F	RDQ150110S05
	12.0 V	12.5 A	40 mA	1474 mA	92.5%	5600 μ F	RDQ150110S12
	24.0 V	6.50 A	60 mA	1541 mA	91.0%	2200 μ F	RDQ150110S24

Notes

- Output Ripple and Noise measured with 10 μ F tantalum and 1 μ F ceramic capacitor across output.
- Add suffix 'N' to the model number to receive the unit with negative logic Remote On/Off.
- An external 220 μ F electrolytic input capacitor is recommended to reduce input ripple voltage.

Mechanical Details

RDQ150

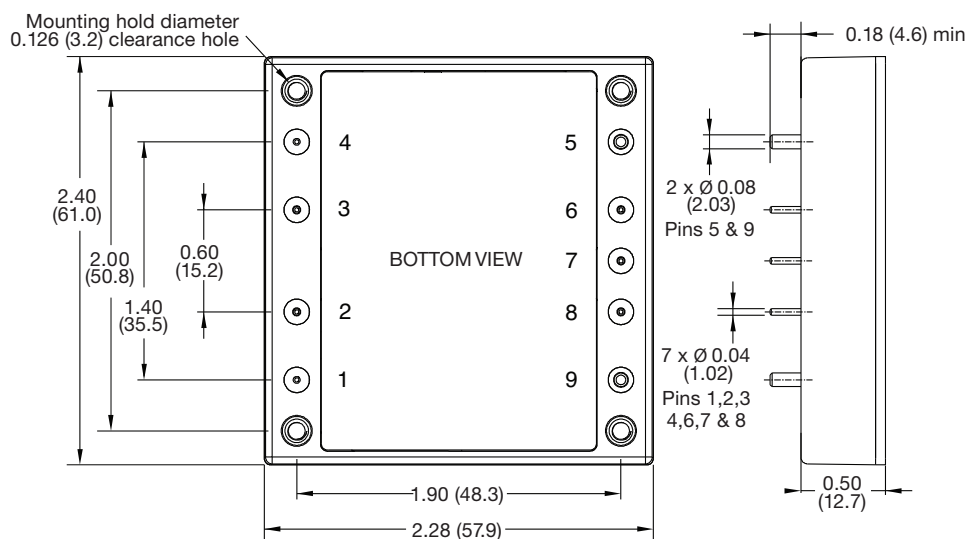

PIN CONNECTIONS	
Pin	Function
1	+Vin
2	Remote On/Off
3	Case
4	-Vin
5	-Vout
6	-Sense
7	Trim
8	+Sense
9	+Vout

Notes

- Dimensions are in inches (mm)
- Tolerances: X.XX = ± 0.02 (X.X = ± 0.5)
X.XXX = ± 0.01 (X.XX = ± 0.25)
- Weight: 0.216 lbs (90 g) approx

Thermal Resistance Information (Derating Curve)

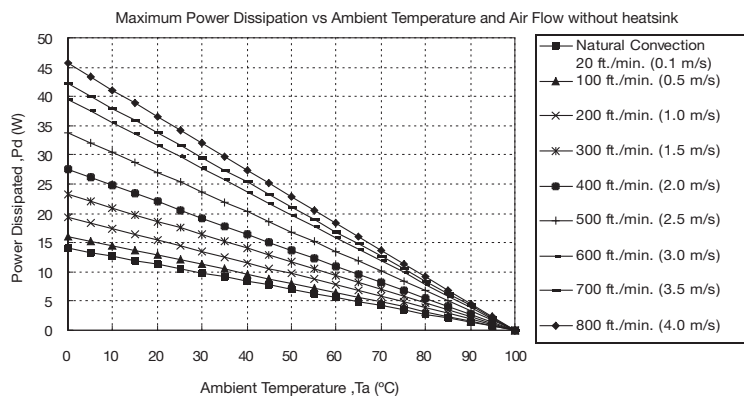

Air Flow Rate	Typical R _{ca}
Natural Convection 20 ft./min (0.1 ms)	7.12 °C/W
100 ft./min (0.5 ms)	6.21 °C/W
200 ft./min (1.0 ms)	5.17 °C/W
300 ft./min (1.5 ms)	4.29 °C/W
400 ft./min (2.0 ms)	3.64 °C/W
500 ft./min (2.5 ms)	2.96 °C/W
600 ft./min (3.0 ms)	2.53 °C/W
700 ft./min (3.5 ms)	2.37 °C/W
800 ft./min (4.0 ms)	2.19 °C/W

R_{ca} = Thermal resistance case to ambient

Suggested EMC Components

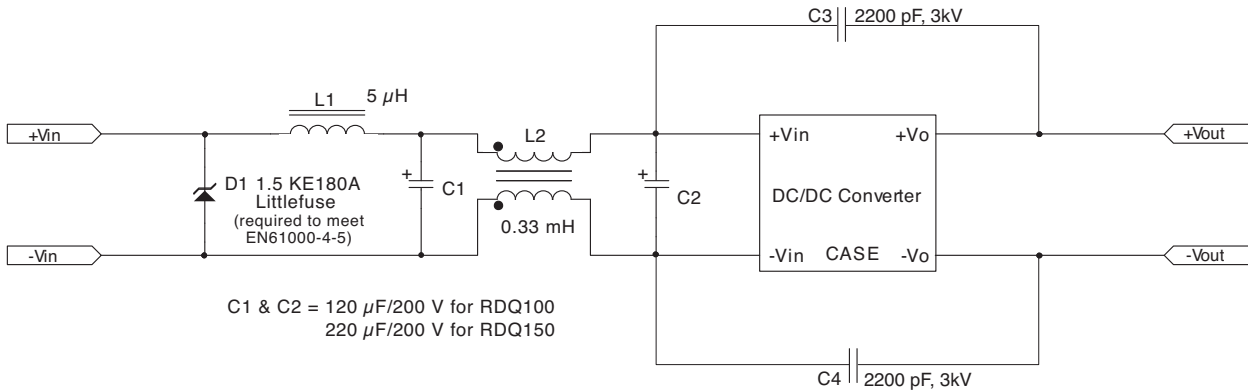

Application Notes

Output Voltage Trim

Voltage trim up

Connect trim resistor Rtrim between Trim pin and -Sense pin.

Voltage trim down

Connect trim resistor Rtrim between Trim pin and +Sense pin

$$R \text{ trim up} = \left(\frac{R1 \left(Vr - Vf \left(\frac{R2}{R2 + R3} \right) \right)}{Vdes - Vnom} \right) - \frac{R2 \times R3}{R2 + R3} \text{ (k}\Omega\text{)}$$

$$R \text{ trim down} = \frac{R1 \times (Vdes - Vr)}{Vnom - Vdes} - R2 \text{ (k}\Omega\text{)}$$

Where: R trim up/down is the external resistor in kΩ. Vnom is the nominal output voltage. Vdes is the desired output voltage. R1, R2, R3 and Vr are internal to the unit and are defined in the table below.

Output Voltage (V)	R1 (k)	R2 (k)	R3 (k)	Vr (V)	Vf (V)
5.0 V	2.32	3.3	0	2.5	0.0
12.0 V	9.10	51.0	5.1	2.5	0.46
24.0 V	20.0	100.0	7.5	2.5	0.46

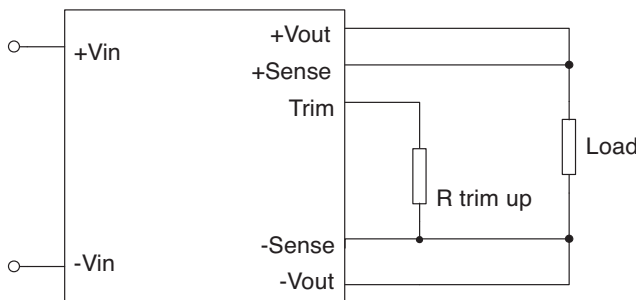

Voltage Trim-up Setup

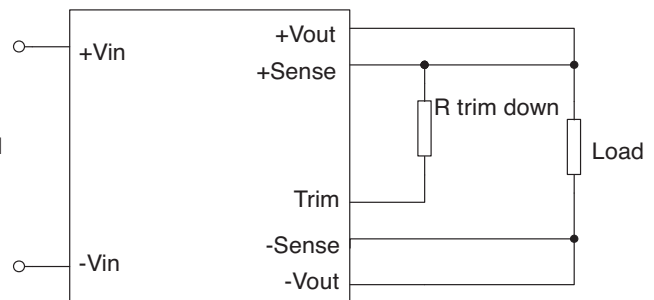

Voltage Trim-down Setup

X-ON Electronics

Largest Supplier of Electrical and Electronic Components

Click to view similar products for [Isolated DC/DC Converters](#) category:

Click to view products by [XP Power](#) manufacturer:

Other Similar products are found below :

[ESM6D044440C05AAQ](#) [FMD15.24G](#) [PSL486-7LR](#) [PSR152.5-7IR](#) [Q48T30020-NBB0](#) [AVO240-48S12B-6L](#) [AVO250-48S28B-6L](#) [NAN-0505](#) [HW-L16D](#) [JAHW100Y1](#) [217-1617-001](#) [22827](#) [SPB05C-12](#) [SQ24S15033-PS0S](#) [18952](#) [19-130041](#) [CE-1003](#) [CE-1004](#) [GQ2541-7R](#) [PSE1000DCDC-12V](#) [RDS180245](#) [MAU228](#) [419-2065-201](#) [449-2075-101](#) [J80-0041NL](#) [V300C24C150BG](#) [419-2062-200](#) [419-2063-401](#) [419-2067-101](#) [419-2067-501](#) [419-2068-001](#) [DCG40-5G](#) [DFC15U48D15](#) [449-2067-000](#) [XGS-0512](#) [XGS-1205](#) [XGS-1212](#) [XGS-2412](#) [XGS-2415](#) [XKS-1215](#) [033456](#) [NCT1000N040R050B](#) [SPB05B-15](#) [SPB05C-15](#) [SSQE48T25025-NAA0G](#) [L-DA20](#) [HP3040-9RG](#) [HP1001-9RTG](#) [XKS-2415](#) [XKS-2412](#)