

# 250 Watts

## SDR Series

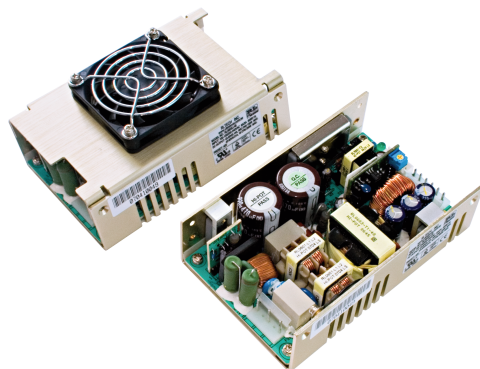

- 3.2”x 5”Footprint
- Fits 1U Applications
- Low Leakage Current
- Up to 600 W Peak Power
- Single & Dual Outputs
- Top Fan & Convection-cooled Versions
- 3 Year Warranty

### Specification

#### Input

Input Voltage	• 90-132 VAC/180-264 VAC, auto ranging
Input Frequency	• 47-63 Hz
Input Current	• 6 A at 115 VAC, 3 A at 230 VAC
Inrush Current	• Max 70 A at 230 VAC, 35 A at 115 VAC, cold start at 25 °C
Power Factor	• EN61000-3-2, class A
Earth Leakage Current	• <500 $\mu$ A at 264 VAC/50 Hz
Input Protection	• Internal T8A/250V fuse in line

#### Output

Output Voltage	• See tables
Output Voltage Trim	• $\pm$ 5% on V1 (V2 of dual output models will track by same % of adjustment)
Initial Set Accuracy	• $\pm$ 1%
Minimum Load	• 1% on single output models, 10% on both outputs for dual models
Start Up Delay	• 1.5 s max at 120 VAC
Start Up Rise Time	• 50 ms typical
Hold Up Time	• 20 ms min at 80% of full load
Line Regulation	• $\pm$ 0.5%
Load Regulation	• $\pm$ 1% 1-100% load for single outputs $\pm$ 3% V1, $\pm$ 7% V2 for dual outputs (except 0312 & 0512 models, $\pm$ 10% regulation on V2)
Over/Undershoot	• 5% max
Transient Response	• 5% max deviation, recovery to within 1% in 500 $\mu$ s for a 50% load change
Ripple & Noise	• 1% pk-pk (see note 3)
Overvoltage Protection	• <130% Vnom on output V1, recycle input to reset
Overtemperature Protection	• Measured internally with auto recovery
Overload Protection	• 110-140%
Short Circuit Protection	• Trip & restart (hiccup mode), auto recovery
Remote On/Off	• Requires a low signal to inhibit output (hiccup mode)
Fan Supply	• 12 VDC, 300 mA, not available on ‘-F’ version with built-in fan

#### General

Efficiency	• Single output models: 3.3 V & 5 V models 70%, 12 V models 80%, all other models >83% at 230 V & full load. Dual output models: >70% at 230 V & full load
Isolation	• 3000 VAC Input to Output 1500 VAC Input to Ground 100 VDC Output to Ground
Switching Frequency	• 29 kHz typical
Power Density	• 10.4 W/in <sup>3</sup>
Signals	• Power Good TTL HIGH within 100-500 ms and LOW $\leq$ 1 ms before loss of regulation
MTBF	• 150 kHrs typical to MIL-HDBK-217F at 25 °C, GB

#### Environmental

Operating Temperature	• 0 °C to +70 °C, derate at 2.5%/ °C from +50 °C to +70 °C for single output & forced air cooled dual output models. For convection cooled dual output models, (see note 7)
Storage Temperature	• -20 °C to +85 °C
Operating Humidity	• 5-90%, non-condensing
Storage Humidity	• 5-90%, non-condensing
Cooling	• ‘-F’ version has built-in fan, others require 16 CFM to meet forced air ratings
Operating Altitude	• 3000 m
Vibration	• 5-50 Hz, acceleration 7.35 m/s <sup>2</sup> on X, Y and Z axis

#### EMC & Safety

Emissions	• EN55032 level B conducted & radiated
Harmonic Currents	• EN61000-3-2, class A
Voltage Flicker	• EN61000-3-3
ESD Immunity	• EN61000-4-2, level 3 Perf Criteria A
Radiated Immunity	• EN61000-4-3, 3 V/m Perf Criteria A
EFT/Burst	• EN61000-4-4, level 2 Perf Criteria A
Surge	• EN61000-4-5, installation class 3, Perf Criteria A
Conducted Immunity	• EN61000-4-6, 3V Perf Criteria A
Dips & Interruptions	• EN61000-4-11 30% 10 ms, 60% 100 ms, 100% 5000 ms, Perf Criteria A, B, B
Safety Approvals	• UL62368-1, CSA62368-1 via cUL, EN62368-1

**Models and Ratings**

Output Voltage	Output Power	Output Current		Ripple & Noise PK-PK <sup>(2)</sup>	Model Number <sup>(3,4)</sup>
		Nominal	Peak <sup>(1)</sup>		
5 V	200 W	40.00 A	120.00 A	50 mV	SDR250AS05-F <sup>(6)</sup>
9 V	225 W	25.00 A	66.67 A	90 mV	SDR250AS09-F <sup>(6)</sup>
12 V	250 W	20.83 A	50.00 A	120 mV	SDR250AS12-F
15 V	250 W	16.70 A	40.00 A	150 mV	SDR250AS15-F
18 V	250 W	13.89 A	33.30 A	180 mV	SDR250AS18-F <sup>(6)</sup>
24 V	250 W	10.42 A	25.00 A	240 mV	SDR250AS24-F
28 V	250 W	8.93 A	21.43 A	280 mV	SDR250AS28-F <sup>(6)</sup>
36 V	250 W	6.94 A	16.67 A	360 mV	SDR250AS36-F
48 V	250 W	5.21 A	12.50 A	480 mV	SDR250AS48-F <sup>(6)</sup>
54 V	250 W	4.63 A	11.10 A	540 mV	SDR250AS54-F <sup>(6)</sup>
60 V	250 W	4.17 A	10.00 A	600 mV	SDR250AS60-F <sup>(6)</sup>

Output Voltage	Output Power	Output Current		Ripple & Noise PK-PK <sup>(2)</sup>	Model Number <sup>(3,4)</sup>
		Nominal	Peak <sup>(1)</sup>		
V1 : +3.3V	200 W	24.0 A	28.8 A	50 mV	SDR250AD0312-F <sup>(6)</sup>
V2 : +12.0V		12.0 A	14.4 A	120 mV	
V1 : +3.3V	200 W	24.0 A	28.8 A	50 mV	SDR250AD0324-F <sup>(6)</sup>
V2 : +24.0V		6.0 A	7.2 A	240 mV	
V1 : +5.0V	200 W	24.0 A	28.8 A	50 mV	SDR250AD0512-F <sup>(6)</sup>
V2 : +12.0V		12.0 A	14.4 A	120 mV	
V1 : +5.0V	200 W	24.0 A	28.8 A	50 mV	SDR250AD0524-F <sup>(6)</sup>
V2 : +24.0V		6.0 A	7.2 A	240 mV	
V1 : +5.0V	200 W	24.0 A	28.8 A	50 mV	SDR250AD0548-F <sup>(6)</sup>
V2 : +48.0V		3.0 A	3.6 A	480 mV	
V1 : +12.0V	250 W	12.0 A	14.4 A	120 mV	SDR250AD1224-F
V2 : +24.0V		6.0 A	7.2 A	240 mV	

**Notes**

1. Peak load can be taken for 500  $\mu$ s. Average power not to exceed max power.
2. Ripple & noise is measured using a 0.1  $\mu$ F ceramic capacitor in parallel with 22  $\mu$ F electrolytic and 20 MHz bandwidth.
3. Add suffix 'D' for optional output terminal block except the 5 V and 9 V output models which are only available with output terminal blocks.<sup>(6)</sup>
4. Add suffix 'E' for optional input terminal block.<sup>(6)</sup>
5. Available for OEM quantities, contact Sales.

**Mechanical Details**

Enclosed with top fan (option -F)

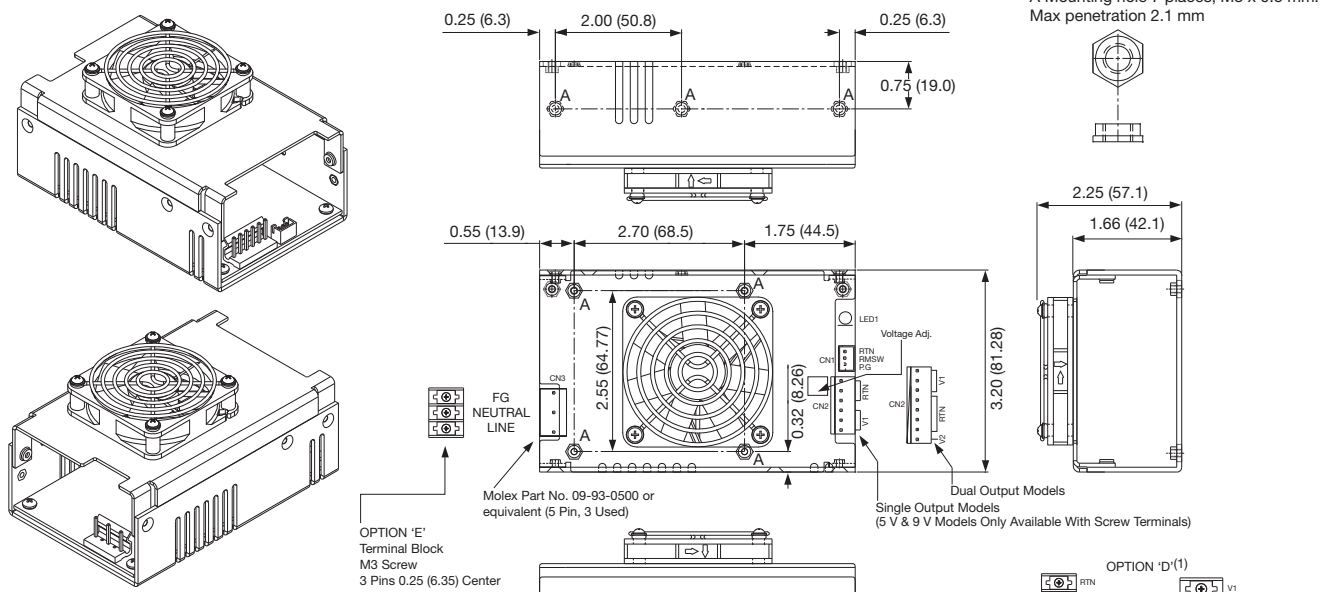

**Notes**

1. All dimensions are in inches (mm). Tolerance:  $\pm 0.012$  ( $\pm 0.3$ )
2. Weight: 0.95 lbs (430 g)
3. Signal connector CN1 mates with JST XHP-3 or equivalent & crimp terminals SXH-002T-P0.6.
4. Input: Molex No. 09-93-0500, crimp terminals Molex series 6838.
5. Output: Molex No. 09-93-0600 for 12 V to 60 V single output models, 09-93-0800 for dual output models, crimp terminals Molex series 6838.
6. Terminal block for 5 V to 9 V single output models.

Mechanical Details

Output Voltage	Forced-cooled		Convection-cooled		Peak Current <sup>(2)</sup>	Ripple & Noise Pk-Pk <sup>(3)</sup>	Model Number <sup>(1,4,5,6)</sup>
	Output Power	Output Current	Output Power	Output Current			
5 V	200 W	40.00 A	100 W	20.00 A	120.00 A	50 mV	SDR250AS05 <sup>(6)</sup>
9 V	225 W	25.00 A	121 W	13.50 A	66.67 A	90 mV	SDR250AS09 <sup>(6)</sup>
12 V	250 W	20.83 A	135 W	11.23 A	50.00 A	120 mV	SDR250AS12
15 V	250 W	16.70 A	135 W	9.00 A	40.00 A	150 mV	SDR250AS15
18 V	250 W	13.89 A	135 W	7.50 A	33.30 A	180 mV	SDR250AS18 <sup>(6)</sup>
24 V	250 W	10.42 A	135 W	5.63 A	25.00 A	240 mV	SDR250AS24
28 V	250 W	8.93 A	135 W	4.82 A	21.43 A	330 mV	SDR250AS28 <sup>(6)</sup>
36 V	250 W	6.94 A	135 W	3.75 A	16.67 A	360 mV	SDR250AS36
48 V	250 W	5.21 A	135 W	2.81 A	12.30 A	480 mV	SDR250AS48 <sup>(6)</sup>
54 V	250 W	4.63 A	135 W	2.50 A	11.10 A	540 mV	SDR250AS54 <sup>(6)</sup>
60 V	250 W	4.17 A	135 W	2.25 A	10.00 A	600 mV	SDR250AS60 <sup>(6)</sup>

Output Voltage	Forced-cooled		Convection-cooled		Peak Current <sup>(2)</sup>	Ripple & Noise Pk-Pk <sup>(3)</sup>	Model Number <sup>(1,4,5,6,7)</sup>
	Output Power	Output Current	Output Power	Output Current			
V1 : +3.3 V	200 W	24.0 A	100 W	12.0 A	28.8 A	50 mV	SDR250AD0312 <sup>(6)</sup>
V2 : +12.0 V		12.0 A		7.0 A	14.4 A	120 mV	
V1 : +3.3 V	200 W	24.0 A	100 W	12.0 A	28.8 A	50 mV	SDR250AD0324 <sup>(6)</sup>
V2 : +24.0 V		6.0 A		4.0 A	7.2 A	240 mV	
V1 : +5.0 V	200 W	24.0 A	100 W	12.0 A	28.8 A	50 mV	SDR250AD0512 <sup>(6)</sup>
V2 : +12.0 V		12.0 A		7.0 A	14.4 A	120 mV	
V1 : +5.0 V	200 W	24.0 A	100 W	12.0 A	28.8 A	50 mV	SDR250AD0524 <sup>(6)</sup>
V2 : +24.0 V		6.0 A		4.0 A	7.2 A	240 mV	
V1 : +5.0 V	200 W	24.0 A	100 W	12.0 A	28.8 A	50 mV	SDR250AD0548 <sup>(6)</sup>
V2 : +48.0 V		3.0 A		2.0 A	3.6 A	480 mV	
V1 : +12.0 V	250 W	12.0 A	135 W	7.0 A	14.4 A	120 mV	SDR250AD1224
V2 : +24.0 V		6.0 A		4.0 A	7.2 A	240 mV	

Notes

1. Add suffix 'L' to model number for optional 500 μA leakage current.<sup>(8)</sup>
2. Peak load can be taken for 500 μs. Average power not to exceed max power.
3. Ripple & noise is measured using a 0.1 μF ceramic capacitor in parallel with 22 μF electrolytic and 20 MHz bandwidth.
4. For optional vented cover add suffix '-C' to model number.
5. Add suffix '-D' for optional output terminal block except the 5 V and 9 V output models which are only available with output terminal blocks.<sup>(6)</sup>
6. Add suffix '-E' for optional input terminal block.<sup>(8)</sup>
7. Operating temperature - 0 °C to +60 °C, derate at 5%/ °C from 50 °C to 60 °C for convection cooled dual output models.
8. Available for OEM quantities, contact Sales.

Mechanical Details

U-Channel

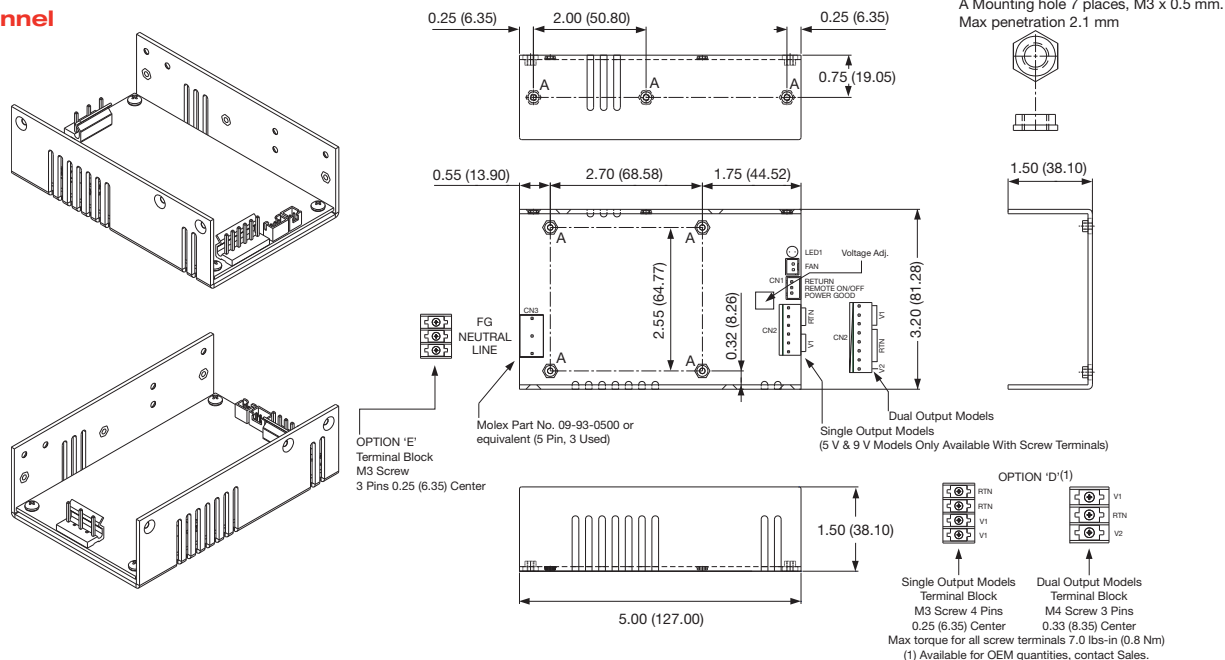

Notes

1. All dimensions are in inches (mm). Tolerance: ±0.012 (±0.3)
2. Weight: 0.88 lbs (400 g)
3. Signal connector CN1 mates with JST XHP-3 or equivalent & crimp terminals SXH-002T-P0.6.
4. Fan connector mates with JST XHP-2 or equivalent & crimp terminals.
5. Input: Molex No. 09-93-0500, crimp terminals Molex series 6838.
6. Output: Molex No. 09-93-0600 for 12 V to 60 V single output models, 09-93-0800 for dual output models, crimp terminals Molex series 6838.
7. Terminal block for 5 V to 9 V single output models.

**Mechanical Details**

**U-Channel with cover (Option 4C)**

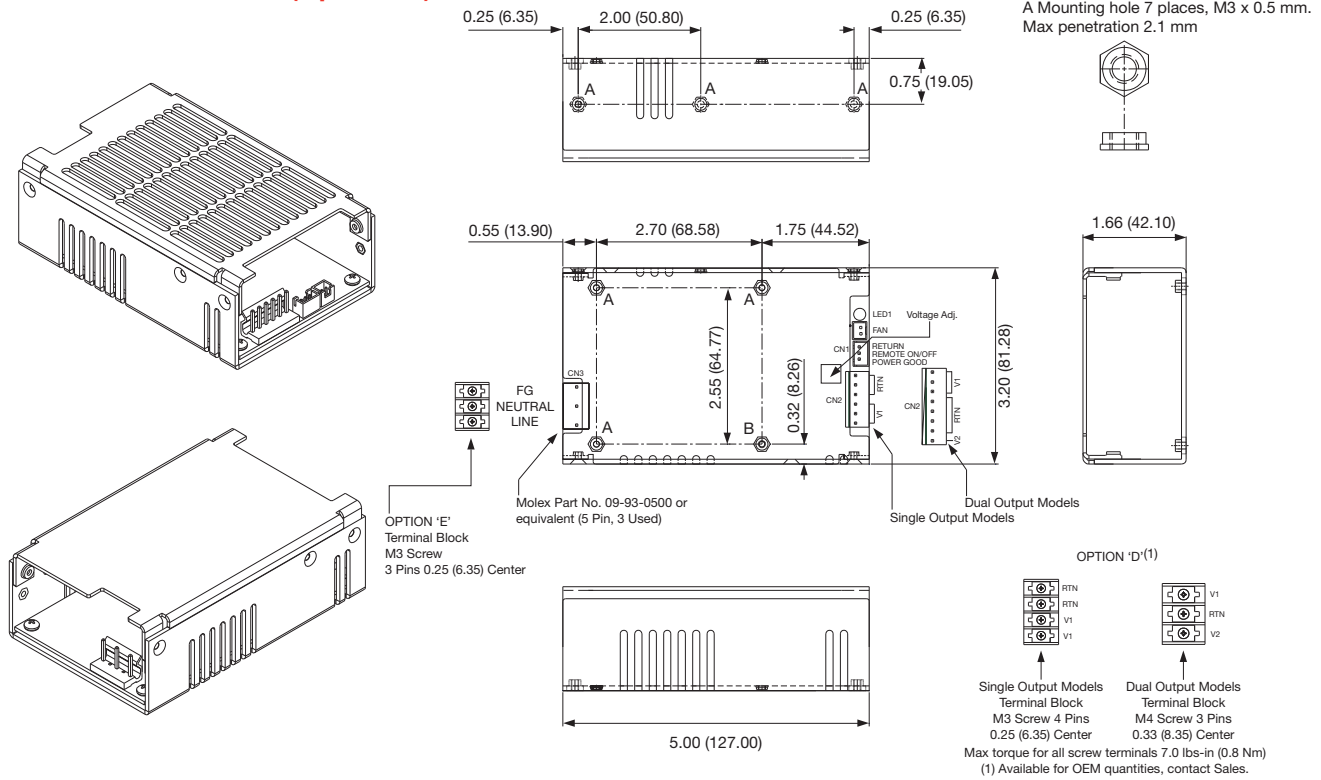

**Notes**

1. All dimensions are in inches (mm). Tolerance:  $\pm 0.012$  ( $\pm 0.3$ )
2. Weight: 0.93 lbs (420 g)
3. Signal connector CN1 mates with JST XHP-3 or equivalent & crimp terminals SXH-002T-P0.6.
4. Fan connector mates with JST XHP-2 or equivalent & crimp terminals.
5. Input: Molex No. 09-93-0500, crimp terminals Molex series 6838.
6. Output: Molex No. 09-93-0600 for 12 V to 60 V single output models, 09-93-0800 for dual output models, crimp terminals Molex series 6838.
7. Terminal block for 5 V to 9 V single output models

**Application Notes**

**Remote On/Off**

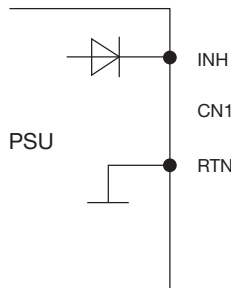

**Note:**

1. Applying  $< 0.3$  V or short between pins 2 and 1 turns the output OFF.
2. Applying  $> 4.5$  V or open circuit between pins 2 and 1 turns output ON.
3. The output will enter hiccup mode. Recommended maximum time is 3 minutes.

**Power Good**

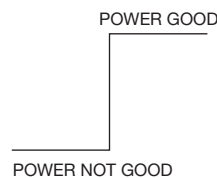
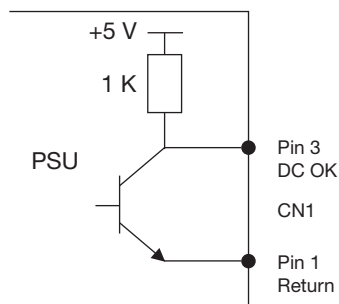

Sink current = 6 mA  
Source current = 1 mA

## X-ON Electronics

Largest Supplier of Electrical and Electronic Components

*Click to view similar products for [Switching Power Supplies](#) category:*

*Click to view products by [XP Power](#) manufacturer:*

Other Similar products are found below :

[70841011](#) [73-551-0005](#) [73-551-0048](#) [PS3E-B12F](#) [PS3E-E12F](#) [AAD600S-4-OP](#) [R22095](#) [KD0204](#) [9021](#) [LDIN100150](#) [LPM000-BBAR-01](#)  
[LPX17S-C](#) [EVS57-10R6/R](#) [FP80](#) [FRV7000G](#) [22929](#) [PS3E-F12F](#) [CQM1IA121](#) [40370121900](#) [VI-PU22-EXX](#) [40370121910](#) [LDIN5075](#)  
[LPM615-CHAS](#) [LPX140-C](#) [09-160CFG](#) [70841025](#) [VPX3000-CBL-DC](#) [VI-LUL-IU](#) [LPM000-BBAR-05](#) [LPM000-BBAR-08](#) [LPM124-](#)  
[OUTA1-48](#) [LPM000-BBAR-07](#) [LPM109-OUTA1-10](#) [LPM616-CHAS](#) [08-30466-1055G](#) [08-30466-2175G](#) [08-30466-2125G](#) [DMB-EWG](#)  
[TVQF-1219-18S](#) [6504-226-2101](#) [CQM1IPS01](#) [SP-300-5](#) [CQM1-IPS02](#) [VI-MUL-ES](#) [22829](#) [08-30466-0065G](#) [VI-RU031-EWWX](#) [08-30466-](#)  
[0028G](#) [EP3000AC48INZ](#) [VP-C2104853](#)