

产品规格书

Fuses Specification

1. 适用范围 (Available range) :

本保险丝适用于保护家用电器，电子仪器，电源供应器、显示器等。

For protecting instruments, power supply devices and telephone sets etc.

2. 型号定义解释 (Model meaning):

4F: 快断系列产品 (4F: Quick Blow Fuses)

4T: 慢断系列产品 (4T: Slow Blow Fuses)

3. 相关标准 (Safety Standards) : GB9364 IEC60127

通过认证 (Approved file No):

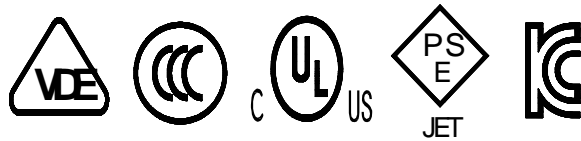

4. 尺寸与结构 (Size and Structure):

4.1 外形、结构及尺寸 (The out view, construction and dimensions):

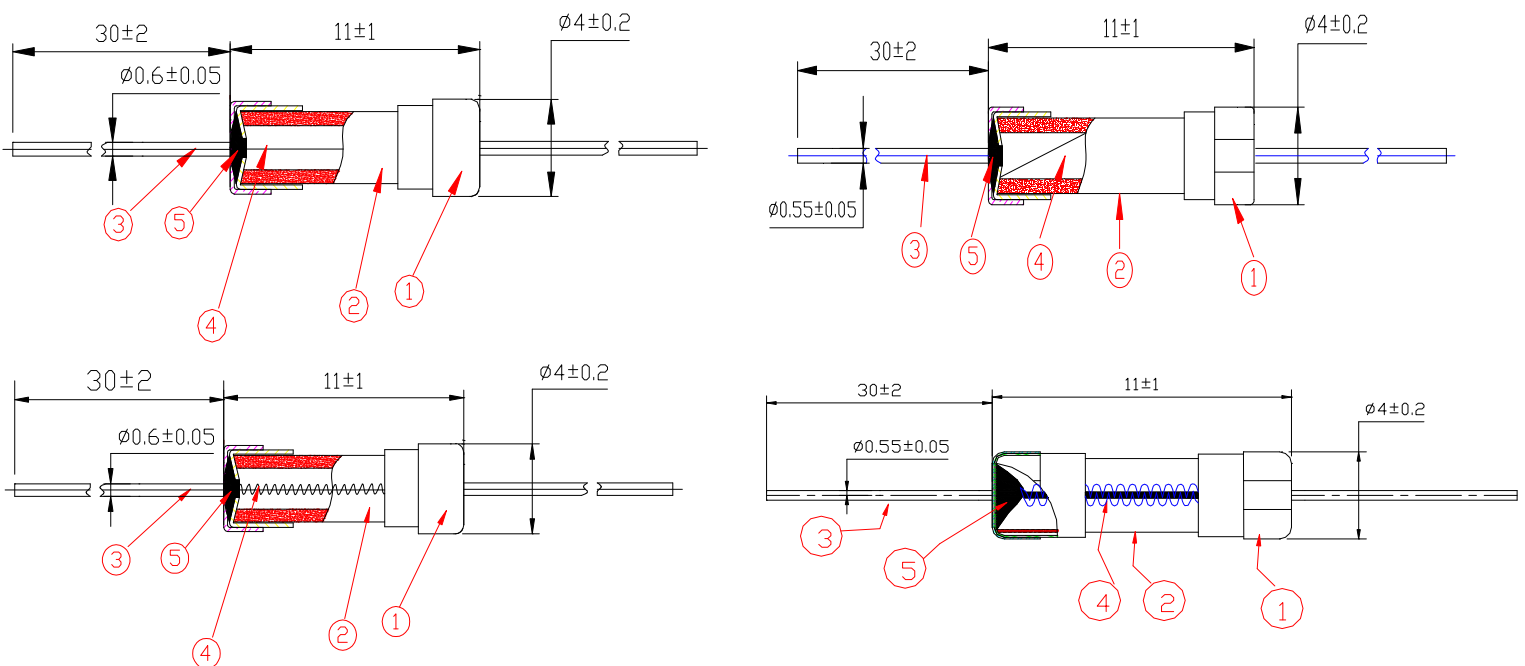

参考下图 Refer to the following figure.

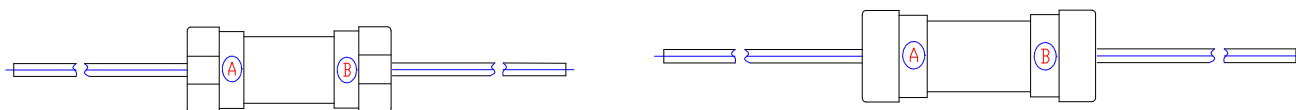

编号 No.	部件 Part Name	材料 Material	备注 Remarks
①	铜帽 Brass Cap	镀镍黄铜 Nickel plated copper	
②	陶瓷管 Ceramic Tube	陶瓷 ceramic	
③	带线 Pigtail	镀锡铜线 tannest plated copper	
④	熔丝 Fuse Element	合金 Alloy	
⑤	焊锡 Solder	锡线 (Sn99. 3%Cu0. 7%) Solder wire(Sn99. 3%Cu0. 7%)	ROHS

4.2 型号及标示 (Model and marking)



型号 Model	A 表示 Indication A	B 表示 Indication B	备注 Remarks
	额定电压/电流 Rated Voltage/Current	商标. 品名. 认证 Trademark. Type. Approved mark	认证号 Approval No.
4F Series	4F F500mA-6. 3A250V		VDE: 40029361 CCC: 2020970207000072 UL: E249609 PSE: JET5173-31007-1005 KC: SU05031-10013 KC: SU05031-10014 KC: SU05031-10015
4T Series	4T T250mA-6. 3A250V		VDE: 40029295 CCC: 2020970207000074 UL: E249609 PSE: JET5173-31007-1006 KC: SU05031-10016 KC: SU05031-10017 KC: SU05031-10018

4.3 陶瓷管 (Ceramic Tube)

管体本体无破裂、缺损等现象。

The tube shall have no defects such as crack, injury and contamination.

4.4 铜帽 (Brass caps)

铜帽应焊接牢固，以保证在未损坏熔断体时，铜帽不能被卸脱。铜帽表面镀层应结实，端帽两端均可承受大小至少为 5N、保持 1min 的轴向拉力。

The cap should be firmly attached so that it is not possible to remove them without damaging the fuse itself. The plated material should be firm. Each of the cap should be bear an axial pull of 5N for 1min.

4.5 焊点 (Soldering joint)

焊接铜帽端时，残留的助焊剂及焊锡等异物不应超出铜帽口和沾附在保险管外表面。

Soldering joint in end cap shall not melt during normal operation and shall not have solder clips on the tube, element in view and outer surface of caps.

4.6 引脚 (Lead)

保险管引脚应铆接牢固，作如下测试时，保险管引脚不应有松动或损坏：

The fuse-links lead should be firmly attached, At the conclusion of testing, the fuse-links lead shall remain firmly attached:

- 1) 拉力测试：固定保险管本体，对引脚施加 10N 的轴向拉力 1min。

Tensile: the force applied shall be 10N

- 2) 推力测试：固定保险管本体，对引脚施加 2N 的轴向推力 1min。

Thrust: the force applied shall be 2N

- 3) 弯折测试：距离铜帽约 2mm 的地方将引脚弯折 90° 一次，并且施加 5N 的拉力。

Bending: the force applied shall be 5N and the number of bends shall be one.

5. 机械特性 (Mechanical characteristics)

保险丝应能承受下列试验:

Fuses should endure both of the following tests:

- 5.1 扭力试验: 固定保险丝的一端铜帽, 然后在另一端铜帽上顺时针和逆时针方向上顺序施加 100g.cm 力矩, 两端铜帽不应松动, 管体也不应破碎。

Wresting test: Fixed one cap of the fuse, applied 100g.cm of torsion power in clockwise and counter-clockwise on the other cap, as a result, the tube shall be no damage and the cap should be no loosening.

- 5.2 拉力试验: 固定保险丝的一端铜帽, 然后在另一端铜帽上, 沿水平轴方向施加 5N 的拉力 1min, 两端铜帽不应松动且管体不应破碎。

Pulling test: Fixed one cap of the fuse, applied level pull force of 5N to the other cap for 1 minute, there shall be no damage with the tube and no loosening with the caps and the pigtails.

- 5.3 管子强度试验: 两端铜帽固定好后, 在管体的中心位置施加 10N 的压力, 管体不应破碎。

Stress test: Fixed two caps of the fuse, applied the stress of 10N to the tube center, there shall be no damage with the tube.

6. 电气特性 (Electrical performance)

6.1 测试条件 (Testing Ambient)

测试条件都应在下列大气条件下进行:

All tests should be carried out under the following conditions:

-温度 (Surrounding temperature): 15°C ~ 35°C;

-相对湿度 (Relative humidity): 45% ~ 75%;

-大气压力 (Atmosphere pressure): 8.6×10^4 Pa ~ 1.06×10^5

6.2 时间/电流特性 (Time-current Characteristic)

电流 (In ratio) 型号类别 (Item No.)	150%	210%	275%
4F 系列 4F Series	> 1h	< 30min	≥ 10ms ≤ 3s
4T 系列 4T Series	> 1h	< 120s	≥ 400ms < 10s

6.3 分断能力 (Breaking capacity)

1) AC 250V 35A 或 10In (注: In 代表额定电流) 取最大。

Breaking capacity: 35A or 10I_n (AC250V), whichever is greater.

2) 每一次测试, 保险管能安全动作, 不能出现以下现象:

In each of the tests, the fuse-link shall operate satisfactorily without any of the following phenomena:

- 持续电弧;
- permanent arcing;
- 引燃;
- ignition;
- 保险管爆炸;
- Bursting of the fuse-link.

注意: 颜色改变不认为是合格。

NOTE: changes in color are not considered as a failure.

型号 Model	额定电流 Rated Current	安全认证分断电流 Safe attestation Breaking current
		
4T/4F 系列 4T/4F Series	In ≤ 3.15A	35A AC 250V
	In > 3.15A	10In AC 250V

6.4 时间电流特性曲线图 (Time-current curves)

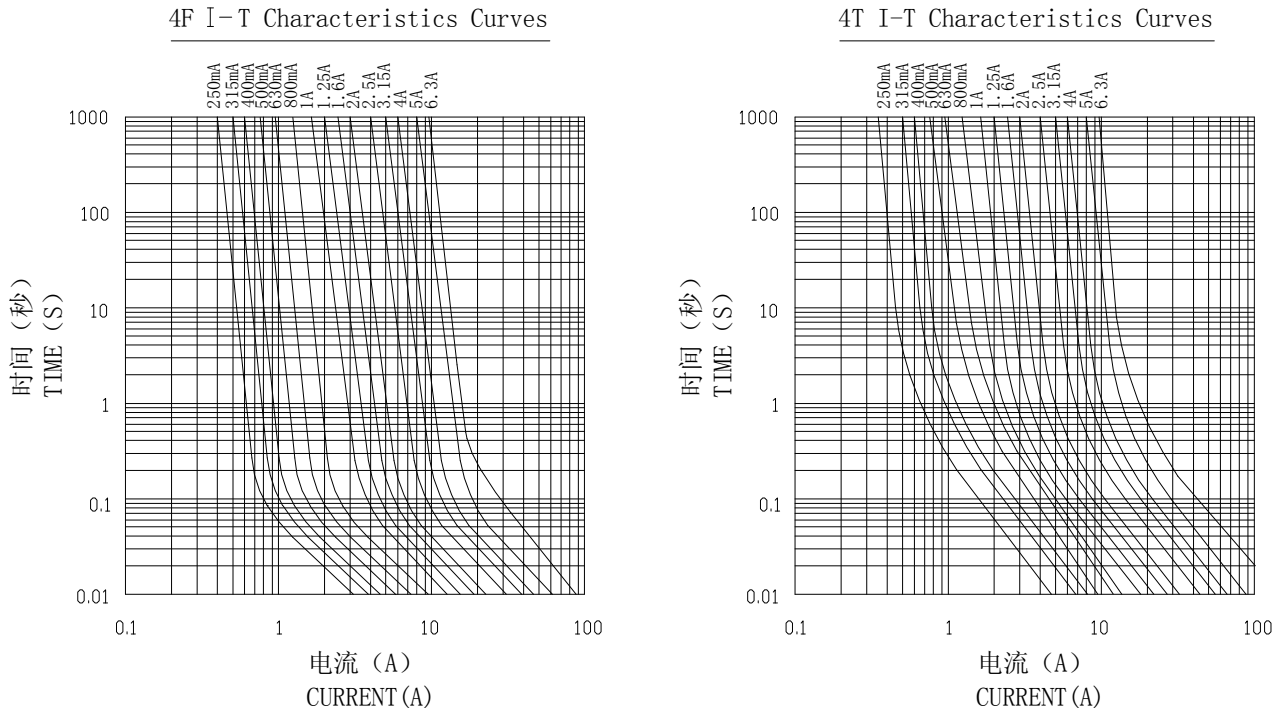

6.5 耐久性试验 (Endurance test)

1) 对保险丝通过 1 倍额定电流 1 小时，然后切断 15 分钟，重复此循环 100 次。

A current $1 I_n$ is passed through the fuse-link for a period of 1h. The current is then switched off for a period of 15 min. The cycle is repeated 100 times.

2) 然后对熔断体通以 1.5 倍额定电流 1 小时。

A current $1.5 I_n$ is then passed through the fuse-link for 1h.

3) 测量熔断体两端的电压降，试验后，熔断体两端的电压降的增大量不大于试验前测得值的 10%。

Finally, the voltage drop across the fuse-link is measured. The voltage drop across the fuse-link after the test shall not have increased by more than 10% of the value measured before the test.

4) 试验后，标记仍应清晰可辨，而且诸如端帽上的焊点不应出现任何明显的劣变。

After the test, the marking shall still be legible and soldered joints on end caps, for example, shall not show and appreciable deterioration.

7. 安装方式及条件 Installation Way and Parameters

7.1 建议如下图安装方式安装

Propose that the following picture installation way is installed

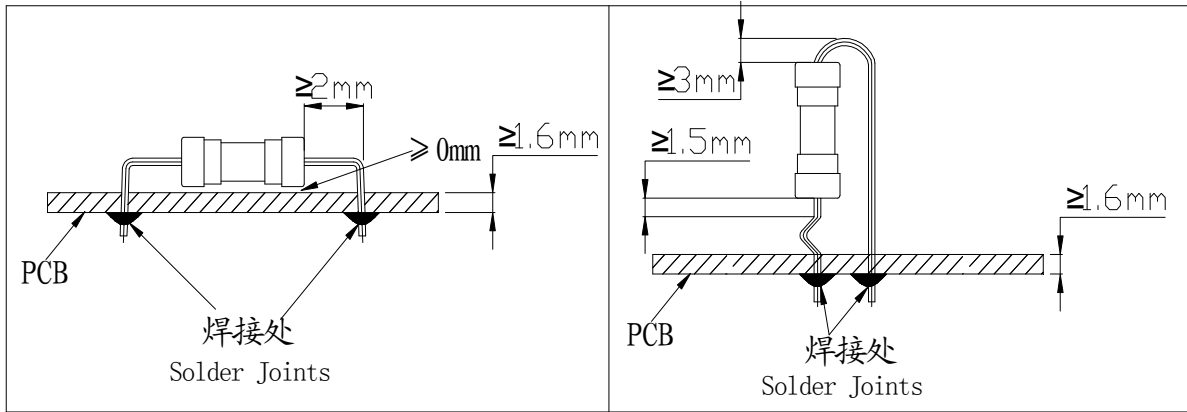

7.2 环保焊接条件 Soldering conditions (RoHS)

波峰焊/Wave solder: 260°C, ≤5S

手工焊/Hand solder: 360°C, ≤1S

8. 环境特性 Environmental characteristic

8.1 温度-电流负荷比曲线 Temperature-Current Curve

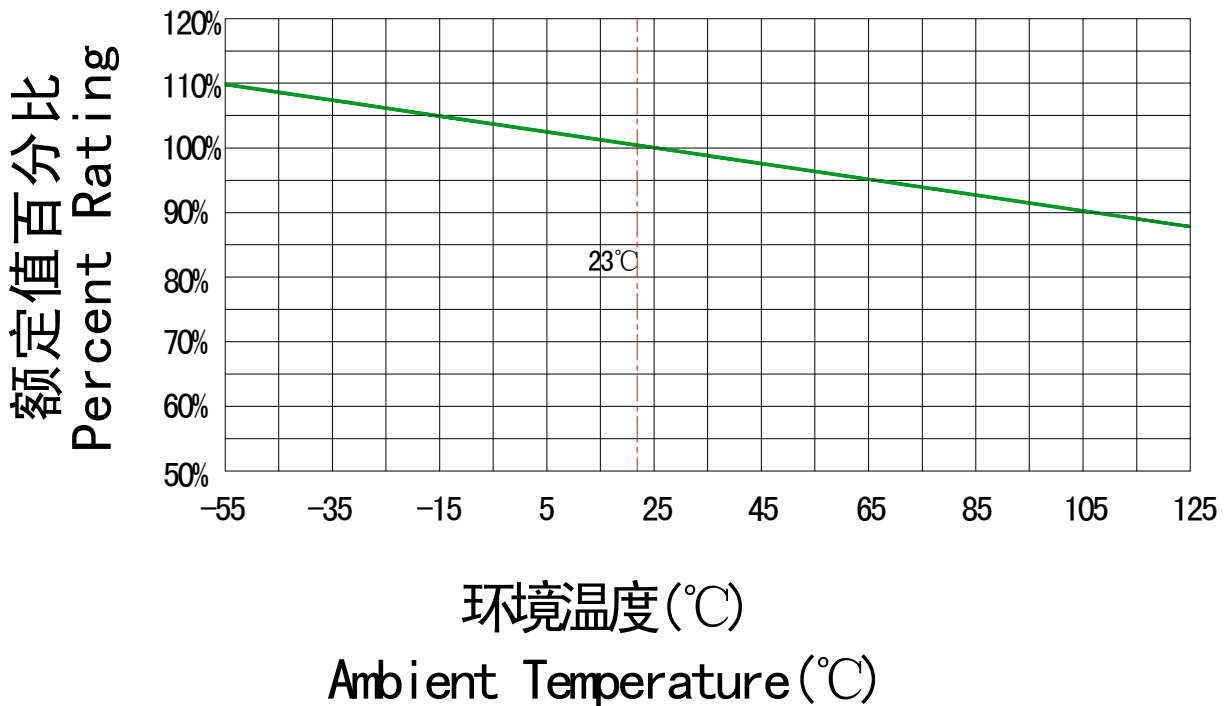

8.2 贮存条件 Storage conditions

贮存温度/Storage temperature: 5℃ ~ 35℃

贮存湿度/Storage humidity: 25% ~ 85%

贮存周期/Storage time: 6 months

9. 信赖性试验 (Reliability test)

项目/Item	试验要求/Test Requirement	试验条件/Test Condition
高低温试验 High & low Temperature Test	试验后保险丝管的电阻符合范围 After test, the resistance value of the fuses shall be in range	测试高温: 85℃, 测试时间: 48h Test high temperature: 85℃, Test time: 48h 测试低温: -20℃, 测试时间: 48h Test low temperature: -20℃, Test time: 48h
高温试验 High Humidity Test	试验后保险丝管的电阻符合范围 After test, the resistance value of the fuses shall be in range	测试温度: 85℃, 测试湿度: 95%, 测试时间: 96h Test temperature: 85℃, Test humidity: 95%, Test time: 96h
落下、冲击实验 Falling Shock Test	铜帽应固定牢固, 以保证在未损坏熔断体时, 铜帽不能被卸下, 铜帽表面镀层应牢固不易脱落, 每个端帽应能经受专用的设备外加轴向拉力 5N, 保持 1 分钟, 陶瓷管必须无缺陷破裂和缺损。试验后保险丝管的电阻符合范围。 Cap should be firmly attached so that it is not possible to remove them without damaging the fuse itself. The means of attachment shall be sufficient to withstand an axial pull of 5N applied to each cap for 1 minute. The cap shall be nickel plated firmly. The glass tube shall have no defects such as crack and injury. After falling shock test, the resistance value of the fuses shall be in range.	保险管从 152cm 高自由落下, 跌落 5 次。 Falling Height: 152cm Falling Times: 5
振动试验 Vibration	试验后保险丝管的电阻符合范围 After test, the resistance value of the fuses shall be in range	振幅 1.5mm, 频率 10 ~ 55 ~ 10Hz, 时间 2 小时 Amplitude: 1.5mm, Frequency: 10 ~ 55 ~ 10Hz, Test time: 2h

10. 产品标志 (Marking)

10.1 保险丝上的标志应易于看清。

The marking on fuse shall be indelibly marked on the end cap and easily visible.

10.2 每个保险丝标记应包含下列内容:

The symbol for every fuse shall be as prescribed below:

1) 额定电流 (Rated current): 250mA-6.3A

2) 额定电压 (Rated voltage): 250V

3) 型号 (Model): 4T/4F

4) 安全认证标志 (Safety mark logo):



5) 厂标 (Trade mark): 

11. 包装 (200PCS/包、4800PCS/盒、24000PCS/箱) 仅供参考, 以实际数量为准.

Packaging (200PCS/Bag, 4800PCS/Box, 24000PCS/ External Carton).



12. 料号解释/Part No. Description

例如:

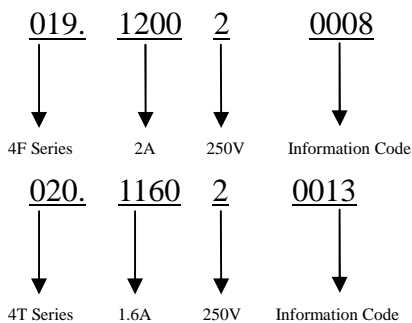

X-ON Electronics

Largest Supplier of Electrical and Electronic Components

Click to view similar products for [Surface Mount Fuses](#) category:

Click to view products by [Xucheng](#) manufacturer:

Other Similar products are found below :

[FHC20402ADTP](#) [NFVC6125S0R50TRF](#) [TF16SN2.00TTD](#) [0686-5000-01](#) [0685-4000-01](#) [FCC16501ABTP](#) [FCC16102ABTP](#)
[FHC16322ADTP](#) [0308001.UR](#) [FCC16202ABTP](#) [7010.9962.63](#) [SEF 12A 65V \(G\)](#) [MST 250mA 250V](#) [TB60](#) [06 100.4](#) [TBF50](#) [TBF40](#)
[2010T315mA250V](#) [06 110.7](#) [12 100.1.5](#) [06 110.5](#) [1206FA-R250](#) [R06.100.6](#) [R12.100.15](#) [R06.000.0.375](#) [R06.000.6](#) [R06.100.0.25](#) [R12.000.8](#)
[R06.000.0.5](#) [R06.000.0.75](#) [R06.000.8](#) [R06.100.0.75](#) [R06.100.8](#) [R06.100.0.375](#) [R06.100.0.5](#) [R06.000.7](#) [R06.100.7](#) [S0603-S-2.0A](#) [F06F3.5](#)
[F12F20](#) [TA3VT2](#) [F12F1](#) [F06F7](#) [F06T3.5](#) [F06F0.375](#) [F06T8](#) [F12F30](#) [4T2A250V](#) [R12.100.7](#) [R12.100.30](#)