

TS-1002
W6.00xD6.00xH

| | |
|---|--|
| 按压力度(Press pressure) : 1.0N/1.6N/2.5N | 开关行程(Switch stroke) : 0.25±0.1mm |
| 操作方式(Operation mode): 正按式/Positive press | 操作寿命(Operation life): 100,000 Cycles Min |
| 储存温度(Storage temperature): -30°C TO +80°C | 焊接温度(Welding temperature): 350±5° 3s |
| 额定负荷(Rated load): DC 12V 50mA | 焊接方式(Welding mode): 插件式/DIP |
| 接触电阻(Contact resistance): 100mΩ max. | 包装方式(Packaging method): 散装/Bulk |
| 绝缘电阻(Insulation resistance): 100MΩ min. | 最小包装(Minimum packing): 1,000/PCS |

外形尺寸 (UNIT:MM) / Size Chart

www.xunpudianzi.com

更多资料请参考技术选型档!

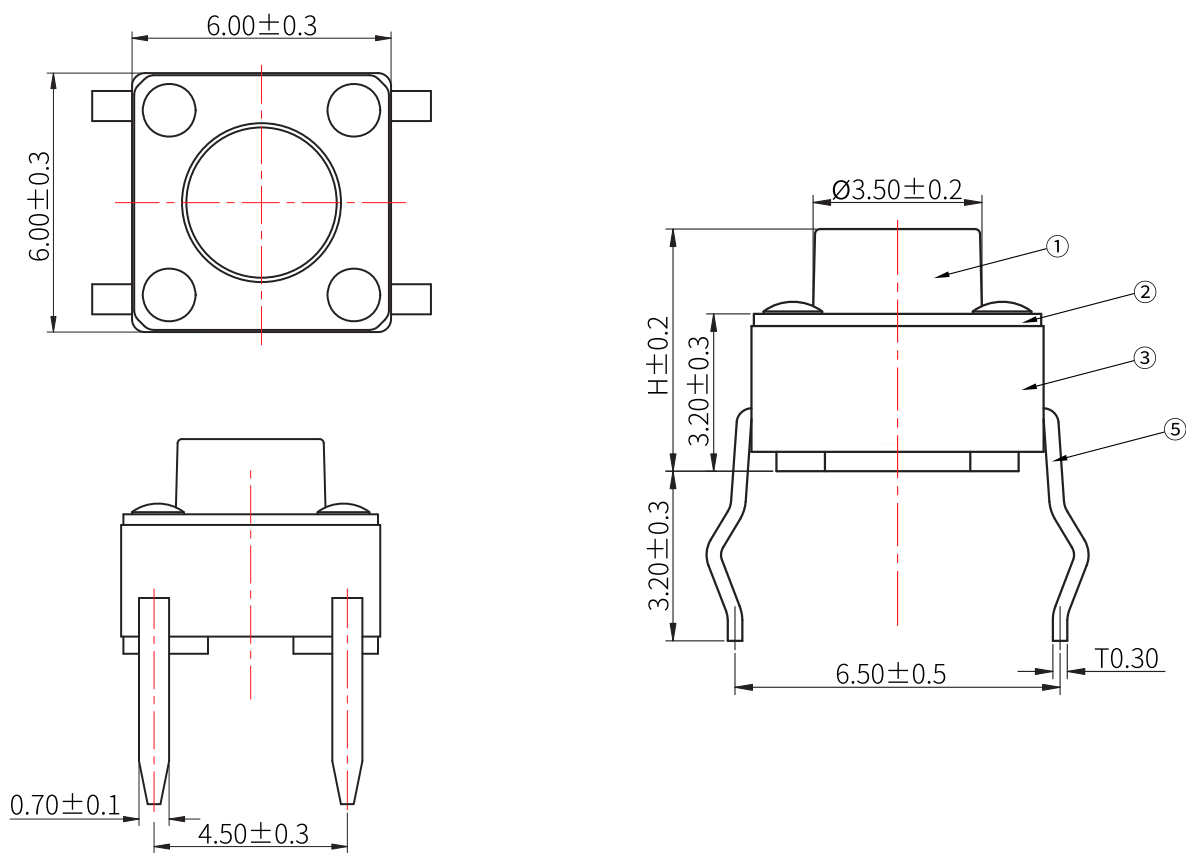

产品编号/Product No

TS-1002-X X XXX XX

| | |
|-------------------|-----------------|
| A: 不锈钢(SUS) | Operating force |
| B: 覆银铜(C5210) | Product height |
| C: 带柱(Column) | |
| R: 不带柱(No Column) | |

产品高度/Product Height

| Code | Product height(mm) | Code | Product height(mm) |
|------|--------------------|-------|--------------------|
| 043 | 4.3 | 065 | 6.5 |
| 045 | 4.5 | 070 | 7.0 |
| 050 | 5.0 | 075 | 7.5 |
| 055 | 5.5 | | |
| 060 | 6.0 | 190 | 19.0 |

材质/Material

| NO | NAME | MATERIAL | FINISHING |
|----|----------------|------------|---------------------|
| ① | 按钮 Button | Nylon | 黑色 Black |
| ② | 盖子 Cover | SPCC | 镀镍 Nickel plated |
| ③ | 基座 Base | Nylon | 黑色 Black |
| ④ | 弹片 Shrapnel | F.Ag/C5210 | 镀银 Silvering |
| ⑤ | 端子 Terminal | Brass | 镀银 Silvering |

操作力度/Operating Force

| Code | Press force(N) | Return force |
|------|----------------|--------------|
| 16 | 1.6±0.5 | 0.4min |
| 26 | 2.6±0.5 | 0.4min |

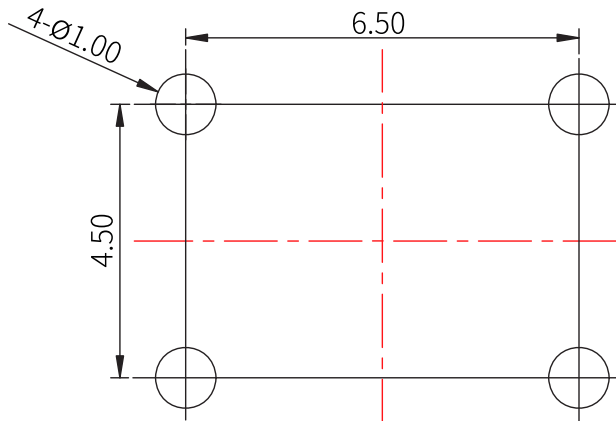

RECOMMENDED P.C.B LAYOUT
安装尺寸图

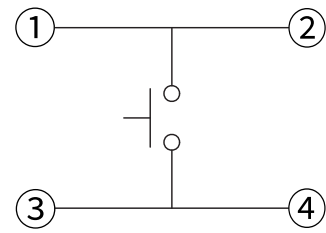

CIRCUIT DIAGRAM
回路图

焊接条件 / Welding conditions

● 回流焊/Reflow soldering

适用表面贴装型产品/Applicable to surface mount products
温度分布/Temperature distribution



● 手焊式/Hand welding

| 项目/Project | 条件/condition |
|-----------------------------------|--------------|
| 焊接温度 Welding temperature | 350°C max. |
| 持续焊接时间 Continuous welding time | 3s max. |
| 焊剂斗容量 Flux bucket capacity | 60W max. |

● 浸焊式/Immersion soldering

| 项目/Project | 条件/condition |
|------------------------------------|---|
| 助焊剂附着量 Flux adhesion | 不附着于零部件贴装面的程度 Not attached to the mounting surface of components |
| 预热温度 Preheating temperature | 印刷电路板焊接面的周围温度 100°C max. The temperature around the welding surface of PCB is 100 °C max |
| 预热温度时间 Preheat temperature time | 60s max. |
| 焊接温度 welding temperature | 260°C max. |
| 焊接浸渍时间 Welding immersion time | 5s max. |
| 焊接次数 Welding times | 2 times max. |

注:

1. 加热方式:以远红外线上下加热方式。
2. 温度测量:用Φ0.1~0.2 的 CA(K)或 CC(T)测量位置在焊接连接部(锡/铜箔面)。
3. 固定方式:采用耐热胶带。

X-ON Electronics

Largest Supplier of Electrical and Electronic Components

Click to view similar products for [Tactile Switches](#) category:

Click to view products by [XUNPU](#) manufacturer:

Other Similar products are found below :

[5GTH92001](#) [5GTH9202242](#) [ADTSA62NV](#) [ADTSA62RV](#) [B3F-3123](#) [1977177-8](#) [1977266-1](#) [ADTSA63NV](#) [ADTSM21NSVTR](#)
[ADTSM25RVTR](#) [ADTSM32NVTR](#) [ADTSMW64RV](#) [FSMRA4JHA04](#) [GS4.70F300QP](#) [3ESH9R](#) [KSC241J](#) [SP DELTA LFS](#) [3FTL600RAS](#)
[3FTL640RAS](#) [Y96K132V0FPLFS](#) [5GSH92001](#) [5GTH9658222](#) [ADTSM31NVTR](#) [2-1977120-7](#) [TSJW-5.2-260-TR](#) [KMT011MNGJLHS](#)
[ADTSG648NV](#) [ADTSM62KSVTR](#) [ADTSM648NV](#) [95C06E3RAT](#) [3ATH9Q](#) [FSM4JSMLXTR](#) [FSM4JSMXL](#) [FSMRA8JHA04](#) [HARS0073](#)
[Y97HS12A5RAFP](#) [Y97BT23B2HAFP](#) [Y33R411N9FPLFT](#) [Y31C01402FPLFS](#) [PTS645SK50SMTR92](#) [ADTSM32NVB](#) [KMS233GPWTLFG](#)
[Y78B42324FP](#) [Y33R21116FPLFT](#) [Y31B43131FPLFG](#) [Y78B64124FP](#) [Y71243251FP](#) [Y33R31119FPLFT](#) [Y97HS12A5TAFP](#)
[PTS638SK25SMTR2LFS](#) [Y97LT25BADBFP](#)