

One Cell Lithium-ion/Polymer Battery Protection IC

GENERAL DESCRIPTION

The XBG6158 ZR Series product is a high integration solution for lithium-ion/polymer battery protection. XBG6158 ZR Series contains advanced power MOSFET, high-accuracy voltage detection circuits and delay circuits. XBG6158 ZR Series is put into an ultra-small DFN2X2-6 package and only one external component makes it an ideal solution in limited space of battery pack.

XBG6158 ZR Series has all the protection functions required in the battery application including overcharging, overdischarging, overcurrent and load short circuiting protection etc. The accurate overcharging detection voltage ensures safe and full utilization on charging. The low standby current drains little current from the cell while in storage.

The device is not only targeted for digital cellular phones, but also for any other Li-Ion and Li-Poly battery-powered information appliances requiring long-term battery life.

- Integrate Advanced Power MOSFET with Equivalent of $22\text{m}\Omega R_{\text{DS(ON)}}$
- Ultra-small DFN2x2-6 Package
- Over-temperature Protection
- Overcharge Current Protection
- Two-step Overcurrent Detection:
 - Over-discharge Current
 - Load Short Circuiting
- Charger Detection Function
- $<1\text{V}(\text{typ.})$ Battery Forbidden Charging Function
- Delay Times are generated inside
- High-accuracy Voltage Detection
- Low Current Consumption
 - Operation Mode: $1.4\mu\text{A}$ typ.
 - Power-down Mode: 10nA max.
- RoHS Compliant and Lead (Pb) Free
- ESD HBM: 8KV ; ESD CDM: 2KV ; ESD MM: 300V

APPLICATIONS

One-Cell Lithium-ion Battery Pack
Lithium-Polymer Battery Pack

FEATURES

- Protection of Charger Reverse Connection
- Protection of Battery Cell Reverse Connection with external load

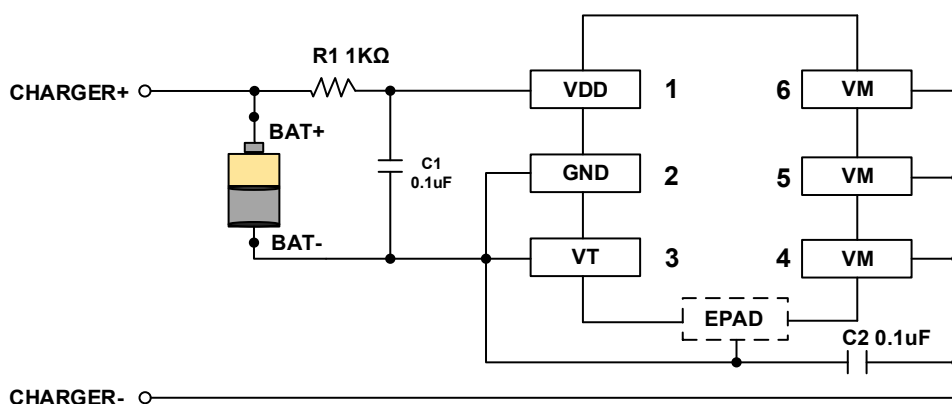

Figure 1. Typical Application Circuit

ORDERING INFORMATION

PART NUMBER	OCV [VCU] (V)	OCR _V [VCL] (V)	ODV [VDL] (V)	ODR _V [VDR] (V)	TOP MARK
XBG6158Q2SZR	4.275±25mV	4.075±50mV	2.8±100mV	3.0±100mV	YWxxx(note)
XBG6158J2SZR	4.425±25mV	4.25±50mV	2.8±100mV	3.0±100mV	YWxxx(note)
XBG6158M2SZR	4.475±25mV	4.30±50mV	2.8±100mV	3.0±100mV	YWxxx(note)
XBG6158UA2SZR	4.525±25mV	4.350±50mV	2.8±100mV	3.0±100mV	YWxxx(note)
XBG6158R2SZR	4.55±25mV	4.375±50mV	2.8±100mV	3.0±100mV	YWxxx(note)
XBG6158V2SZR	4.575±25mV	4.40±50mV	2.8±100mV	3.0±100mV	YWxxx(note)

Note:1).“YW” is manufacture date code, “Y” means the year, “W” means the week.
 2).“xxx” is internal product code of XySemi.

PIN CONFIGURATION

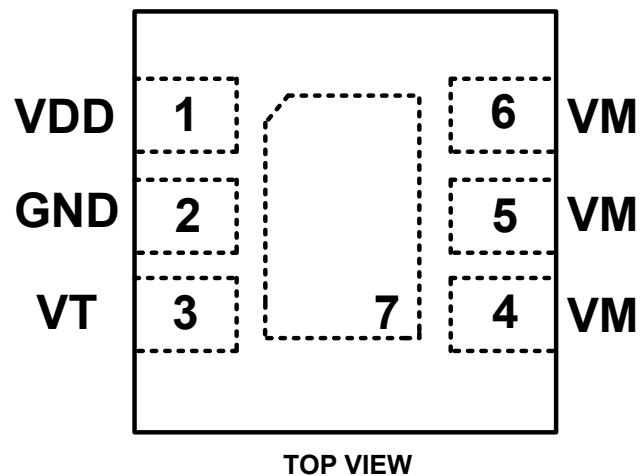

Figure 2. PIN Configuration



XBG6158 ZR Series

PIN DESCRIPTION

XBG6158 ZR SERIES PIN NUMBER	PIN NAME	PIN DESCRIPTION
1	VDD	Power Supply.
2	GND	Ground, connect the negative terminal of the battery to these pins.
3	VT	For test mode debugging(Can be connected to ground).
4,5,6	VM	The negative terminal of the battery pack. The internal FET switch connects this terminal to GND.
7	EPAD	Please connected EPAD with mass metal GND.

ABSOLUTE MAXIMUM RATINGS

(NOTE: DO NOT EXCEED THESE LIMITS TO PREVENT DAMAGE TO THE DEVICE. EXPOSURE TO ABSOLUTE MAXIMUM RATING CONDITIONS FOR LONG PERIODS MAY AFFECT DEVICE RELIABIL-

PARAMETER	VALUE	UNIT
VDD input pin voltage	-0.3 to 12	V
VM input pin voltage	-15 to 15	V
Operating Ambient Temperature	-40 to 85	°C
Maximum Junction Temperature	150	°C
Storage Temperature	-55 to 150	°C
Lead Temperature (Soldering, 10 sec)	300	°C
Power Dissipation at T=25°C	0.4	W
Package Thermal Resistance (Junction to Ambient) θ_{JA}	250	°C/W
Package Thermal Resistance (Junction to Case) θ_{JC}	130	°C/W
ESD HBM	8000	V
ESD MM	300	V
ESD CDM	2000	V

ELECTRICAL CHARACTERISTICS

Typical and limits appearing in normal type apply for TA = 25°C, unless otherwise specified.

PARAMETER	SYMBOL	TEST CONDITIONS	MIN	TYP	MAX	UNIT
Detection voltage						
0V Battery forbidden charge Battery voltage	*V _{01NH}	0V Battery forbidden charge	0.9	1	1.2	V
Detection Current						
Over-discharge Current Detection	I _{IOV1}	V _{DD} =3.6V	0.55	0.8	1.05	A
Overcharge Current Detection	I _{CHOC}	V _{DD} =3.6V	1.16	1.7	2.25	A
Load Short-Circuiting Detection	*I _{SHORT}	V _{DD} =3.6V	1.88	2.7	3.52	A
Current Consumption						
Current Consumption in Normal Operation	I _{OPE}	V _{DD} =3.6V V _M =0V		1.4	2	μA
Current Consumption in Power Down	I _{PD}	V _{DD} =2.0V V _M pin floating			10	nA
VM Internal Resistance						
Internal Resistance between VM and V _{DD}	R _{VMD}	V _{DD} =2.0V V _M pin floating	200	300	400	kΩ
Internal Resistance between VM and GND	R _{VMS}	V _{DD} =3.6V V _M =1.0V	50	100	150	kΩ
FET on Resistance						
Equivalent FET on Resistance	*R _{DS(ON)}	V _{DD} =3.6V I _{VM} =0.1A		22	29	mΩ
Over Temperature Protection						
Over Temperature Protection	*T _{SHD+}			150		°C
Over Temperature Recovery Degree	*T _{SHD-}			110		°C
Detection Delay Time						
Overcharge Voltage Detection Delay Time	t _{CU}		70	160	250	mS
Overdischarge Voltage Detection Delay Time	t _{DL}		15	40	65	mS
Overdischarge Current1 Detection Delay Time	t _{IOV1}	V _{DD} =3.6V	5	10	20	mS
Overcharge Current Detection Delay Time	t _{CHOC}	V _{DD} =3.6V	5	10	20	mS
Load Short-Circuiting Detection Delay Time	*t _{SHORT}	V _{DD} =3.6V	80	200	620	μS

Note1: *---The parameter is guaranteed by design.

FUNCTIONAL BLOCK DIAGRAM

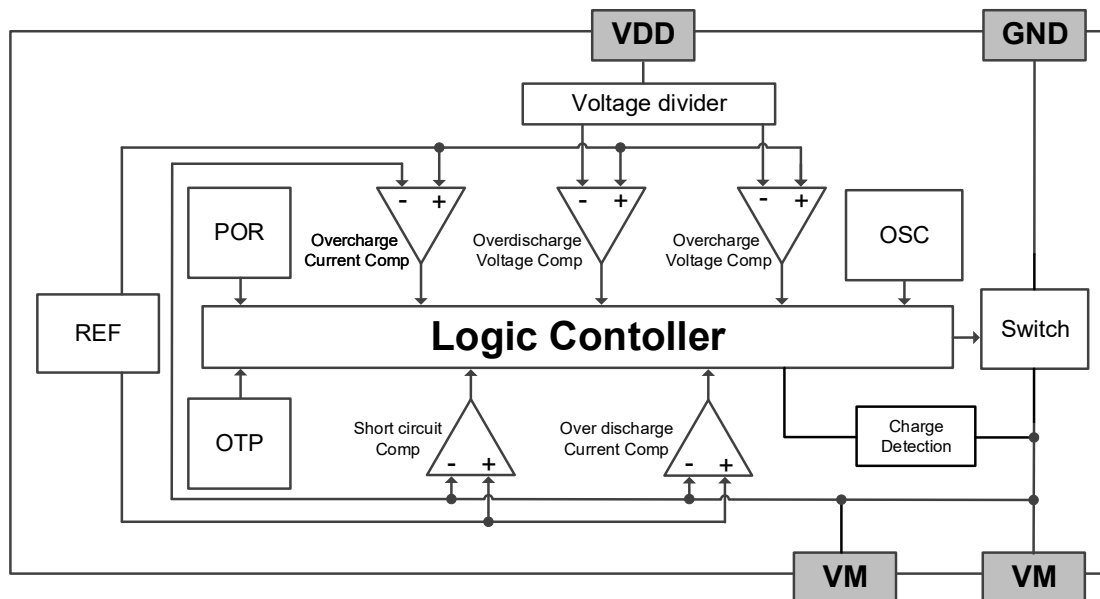

Figure 3. Functional Block Diagram

FUNCTIONAL DESCRIPTION

The XBG6158 ZR Series monitors the voltage and current of a battery and protects it from being damaged due to overcharge voltage, overdischarge voltage, overdischarge current, and short circuit conditions by disconnecting the battery from the load or charger. These functions are required in order to operate the battery cell within specified limits.

The device requires only one external capacitor. The MOSFET is integrated and its $R_{DS(ON)}$ is as low as 22mΩ typical.

Normal operating mode

If no exception condition is detected, charging and discharging can be carried out freely. This condition is called the normal operating mode.

Overcharge Condition

When the battery voltage becomes higher than the overcharge detection voltage (V_{CU}) during charging under normal condition and the state continues for the overcharge detection delay time (t_{CU}) or longer, the XB

G6158 ZR Series turns the charging control FET off to stop charging. This condition is called the overcharge condition. The overcharge condition is released in the following two cases:

1. When the battery voltage drops below the overcharge release voltage (V_{CL}), the XBG6158 ZR Series turns the charging control FET on and returns to the normal condition.

2. When a load is connected and discharging starts, the XBG6158 ZR Series turns the charging control FET on and returns to the normal condition. The release mechanism is as follows: the discharging current flows through an internal parasitic diode of the charging FET immediately after a load is connected and discharging starts, and the VM pin voltage increases about 0.7 V (forward voltage of the diode) from the GND pin voltage momentarily. The XBG6158 ZR Series detects this voltage and releases the overcharge condition. Consequently, in the case that the battery voltage is equal to or lower than the overcharge detection voltage (V_{CU}), the XBG6158 ZR Series returns to the normal condition immediately.

ely, but in the case the battery voltage is higher than the overcharge detection voltage (V_{CU}), the chip does not return to the normal condition until the battery voltage drops below the overcharge detection voltage (V_{CU}) even if the load is connected. In addition, if the VM pin voltage is equal to or lower than the overcurrent 1 detection voltage when a load is connected and discharging starts, the chip does not return to the normal condition.

Remark :

If the battery is charged to a voltage higher than the overcharge detection voltage (V_{CU}) and the battery voltage does not drop below the overcharge detection voltage (V_{CU}) even when a heavy load, which causes an overcurrent, is connected, the overcurrent does not work until the battery voltage drops below the overcharge detection voltage (V_{CU}). Since an actual battery has, however, an internal impedance of several dozens of $m\Omega$, and the battery voltage drops immediately after a heavy load which causes an overcurrent is connected, the overcurrent works. Detection of load short-circuiting works regardless of the battery voltage.

Overdischarge Condition

When the battery voltage drops below the overdischarge detection voltage (V_{DL}) during discharging under normal condition and it continues for the overdischarge detection delay time (t_{DL}) or longer, the XBG6158 ZR Series turns the discharging control FET off and stops discharging. This condition is called overdischarge condition. After the discharging control FET is turned off, the VM pin is pulled up by the R_{VMD} resistor between VM and VDD in XBG6158 ZR Series. Meanwhile when VM is bigger than $1.5V_{(typ.)}$ (the load short-circuiting detection voltage), the current of the chip is reduced to the power-down current (I_{PDN}). This condition is called power-down condition. The VM and VDD pins are shorted by the R_{VMD} resistor in the IC under the overdischarge and power-down conditions.

The power-down condition is released when a charger is connected and the potential difference between VM and VDD beco

mes $1.3V_{(typ.)}$ or higher (load short-circuiting detection voltage). At this time, the FET is still off. When the battery voltage becomes the overdischarge detection voltage (V_{DL}) or higher (see note), the XBG6158 ZR Series turns the FET on and changes to the normal condition from the overdischarge condition.

Remark:

If the VM pin voltage is no less than the charger detection voltage (V_{CHA}), when the battery under overdischarge condition is connected to a charger, the overdischarge condition is released (the discharging control FET is turned on) as usual, provided that the battery voltage reaches the overdischarge release voltage (V_{DU}) or higher.

Overcurrent Condition

When the discharging current becomes equal to or higher than a specified value (the VM pin voltage is equal to or higher than the overcurrent detection voltage) during discharging under normal condition and the state continues for the overcurrent detection delay time or longer, the XBG6158 ZR Series turns off the discharging control FET to stop discharging. This condition is called overcurrent condition. (The overcurrent includes overcurrent, or load short-circuiting.)

The VM and GND pins are shorted internally by the R_{VMS} resistor under the overcurrent condition. When a load is connected, the VM pin voltage equals the VDD voltage due to the load.

The overcurrent condition returns to the normal condition when the load is released and the impedance between the B+ and B- pins becomes higher than the automatic recoverable impedance. When the load is removed, the VM pin goes back to the GND potential since the VM pin is shorted to the GND pin with the R_{VMS} resistor. Detecting that the VM pin potential is lower than the overcurrent detection voltage (V_{IOV1}), the IC returns to the normal condition.

Abnormal Charge Current Detection

If the VM pin voltage drops below the charger detection voltage (V_{CHA}) during charging under the normal condition and it continues for the overcharge detection delay time (t_{CU}) or longer, the XBG6158 ZR Series turns the charging control FET off and stops charging. This action is called abnormal charge current detection.

Abnormal charge current detection works when the discharging control FET is on and the VM pin voltage drops below the charger detection voltage (V_{CHA}). When an abnormal charge current flows into a battery in the overdischarge condition, the XBG6158 ZR Series consequently turns the charging control FET off and stops charging after the battery voltage becomes the over discharge detection voltage and the overcharge detection delay time (t_{CU}) elapses.

Abnormal charge current detection is released when the voltage difference between VM pin and GND pin becomes lower than the charger detection voltage (V_{CHA}) by separating the charger. Since the 0 V battery charging function has higher priority than the abnormal charge current detection function, abnormal charge current may not be detected by the product with the 0 V battery charging function while the battery voltage is low.

Load Short-circuiting condition

If voltage of VM pin is equal or below short circuiting protection voltage (V_{SHORT}), the XBG6158 ZR Series will stop discharging and battery is disconnected from load. The maximum delay time to switch current off is t_{SHORT} . This status is released when voltage of VM pin is higher than short protection voltage (V_{SHORT}), such as when disconnecting the load.

Delay Circuits

The detection delay time for overdischarge current 2 and load short-circuiting starts when overdischarge current 1 is detected. As soon as overdischarge current 2 or load short-circuiting is detected over detection delay time for overdischarge current 2 or load short-circuiting, the XBG6158 ZR Series

stops discharging. When battery voltage falls below overdischarge detection voltage due to overdischarge current, the XBG6158 ZR Series stop discharging by overdischarge current detection. In this case the recovery of battery voltage is so slow that if battery voltage after overdischarge voltage detection delay time is still lower than over discharge detection voltage, the XBG6158 ZR Series shifts to power-down.

0V Battery Charging Forbidden Function ^{(1) (2) (3)}

When connecting the battery with internal short circuit (0 V battery), prohibit charging function. When the battery voltage is below the battery voltage (V_{OINH}), the gate pole of the FET for charge control is fixed at the BAT- terminal voltage, and charging is prohibited. When the battery voltage is above V_{OINH} , it can be charged.

As shown in figure 4. $V_{bat}=2.0$ V (current limiting 10 mA), $V_{ch}=4.2$ (current limiting 10 mA); Reduce V_{bat} voltage again: $V_{step}=-1$ mV; The initial V_{bat} current is 10 mA, and the voltage point when the V_{bat} current is less than 1 mA is the forbidden charging voltage V_{OINH} .

Note:

There are lithium-ion batteries that are not recommended to be recharged after being fully discharged. This is determined by the characteristics of lithium-ion battery, so please confirm the details with the battery manufacturer when you decide to charge the 0 V battery < possible > or < forbidden >.

V_{bat} need to be tested with a battery simulator; if there is no battery simulator, replace the battery simulator with power and load.

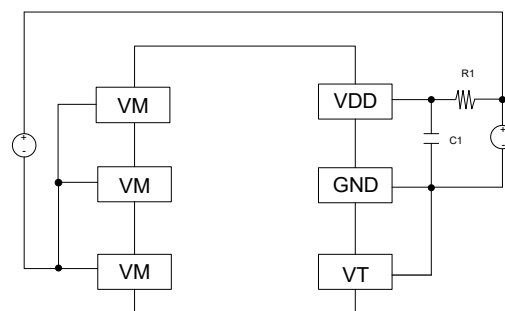

Figure 4

TIMING CHART

1. Overcharge and Overdischarge voltage detection

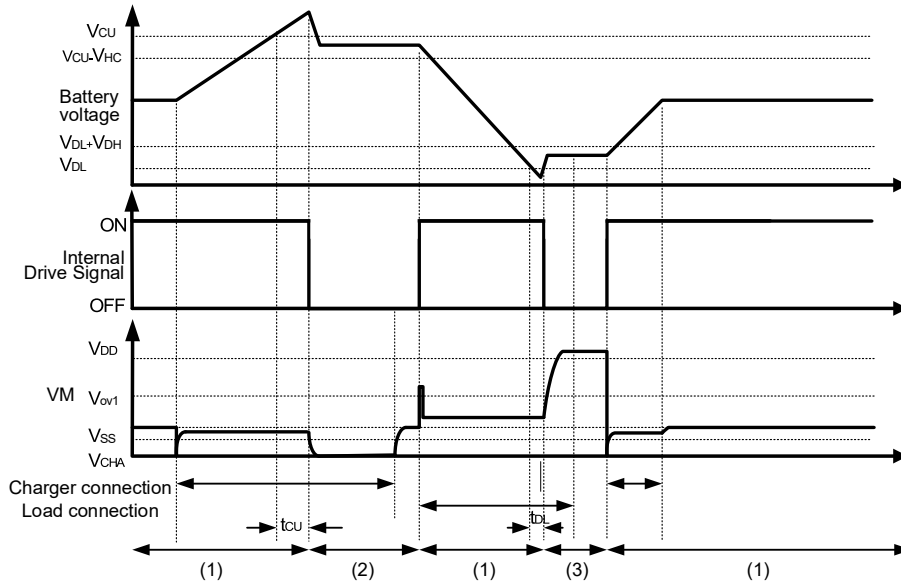

Figure5-1 Overcharge and Overdischarge Voltage Detection

Remark: (1) Normal condition (2) Overcharge voltage condition (3) Overdischarge voltage condition

2. Overdischarge Current and Load Short detection

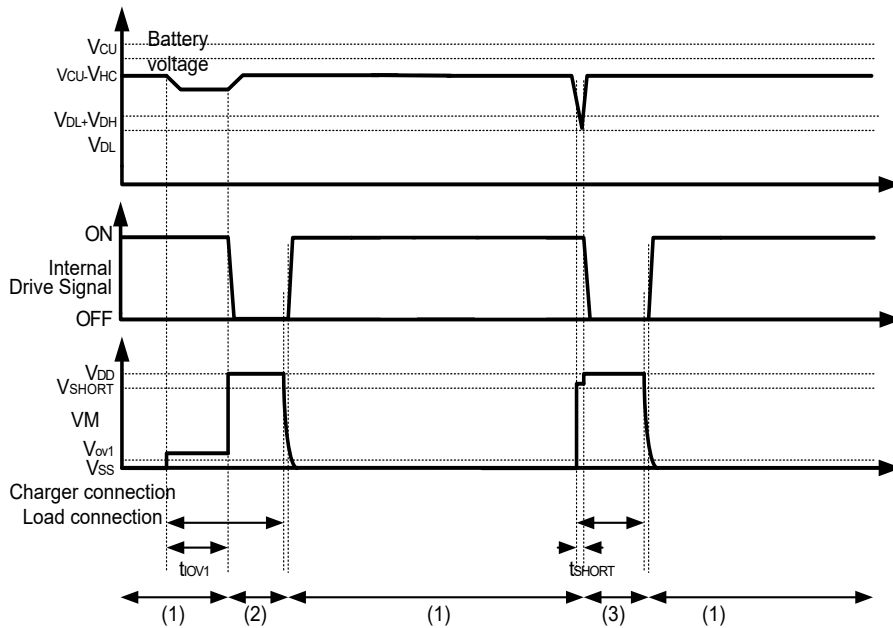

Figure5-2 Overdischarge Current and Short Detection

Remark: (1) Normal condition (2) Overcharge voltage condition (3) Overdischarge voltage condition

3. Abnormal Charger Detection

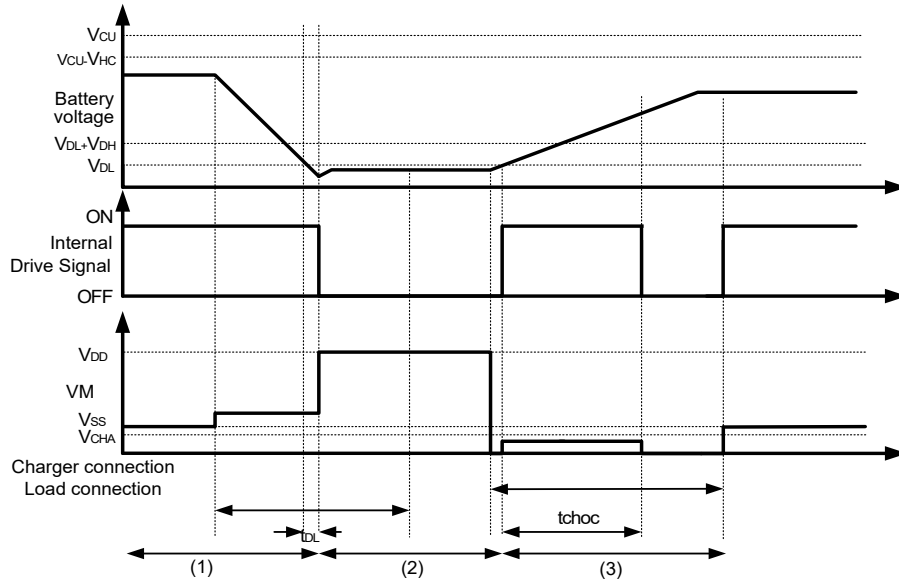

Figure5-3 Abnormal Charger Detection

Remark: (1) Normal condition (2) Overdischarge voltage condition (3) Overcharge voltage condition

TYPICAL APPLICATION

As shown in Figure 6, the current path which must be kept as short as possible. For thermal management, ensure that these trace widths are adequate. C1 is a decoupling capacitor which should be placed as close as possible to XBG6158 ZR Series.

If add one 0.1uF capacitor between VM pin and GND pin closely, the system ESD level and anti-interference capability of circuit will improve greatly.

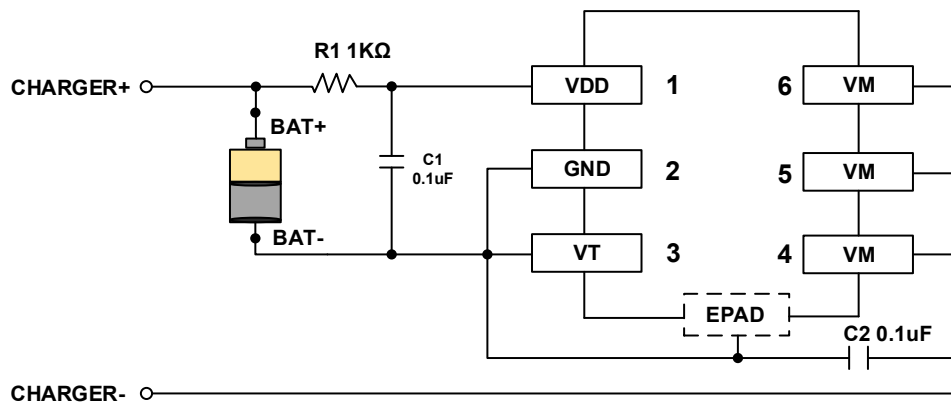

Figure 6 XBG6158 ZR SERIES in a Typical Battery Protection Circuit

Symbol	Typ	Value range	Unit
R1	1	-	KΩ
C1	0.1	0.1~2.2	μF

Remark:

- 1.The above parameters may be changed without notice;
- 2.The schematic diagram and parameters of the IC are not used as the basis to ensure the operation of the circuit. Please conduct full measurement on the actual application circuit before setting the parameters.
- 3.If the resistance value is large , the overcharging voltage will be correspondingly larger by several mV.

Precautions

- Pay attention to the operating conditions for input/output voltage and load current so that the power loss in XBG6158 ZR series does not exceed the power dissipation of the package.
- Do not apply an electrostatic discharge to this XBG6158 ZR series that exceeds the performance ratings of the built-in electrostatic protection circuit.

APPLIED MEASUREMENT METHOD

(1).Overcharge characteristic test method:

a. According to the figure7-1, connect the power supply DC1 to the B + and GND pins of the system board and set the voltage to about 3.6V. Connect the power supply from GND to VM to DC2 power supply and set 100mV current limiting 10mA. Observe the waveform.

b. Adjust the power supply voltage V1 and increase it by 0.001V until the output level of VM pin c changes from 0 to negative (-100mV). Record the overcharge protection voltage and measure the protection delay.

c. Adjust the power supply voltage V1 to decrease by 0.001V until the output voltage of VM pin is recovered from negative (-100mV) to 0 level, and record the overcharge recovery voltage.

(2).Over discharge characteristic test method:

a. According to the figure7-2, connect the power supply DC1 to the B + and GND pins of the system board and set the voltage to about 3.6V. Connect the DC2 power supply from VM to GND, set the 100mV current limiting 10mA, and observe the waveform.

b. Adjust the power supply voltage V1 and increase it by 0.001V until the output level of VM pin c changes from 0 to positive (100mV). Record the overcharge protection voltage and measure the protection delay.

c. Adjust the power supply voltage V1 to decrease by 0.001 V until the output voltage of VM pin is restored from positive (100 mV) to 0 level, and record the overcharge recovery voltage.

(3).Discharge over current test method:

a. According to the figure7-3, connect the DC1 power supply to the B + and GND pins of the system board and set the voltage to about 3.0V/3.6V/4.2V. Connect the electronic load from B + to VM and observe the waveform.

b. Adjust the electronic load increase it by 0.1A step, detect that the current from B + to VM is turned off and meet the delay standard (about 10ms), and record the discharge delay time.

(4).Charging over current test method:

a. According to the figure7-4, connect the DC1 power supply to the B + and GND pins of the system board and set the voltage to about 3.0V/3.6V/4.2V, and load DC2 power supply from GND to VM.

b. Adjust the current limiting value of DC2 power supply to increase by 0.1A step, detect that the current from GND to VM is turned off and meet the delay standard(about 10ms), and record the charging over-current delay time.

(5).Iq test method:

a. As shown in the figure7-5, connect the positive pole of DC1 to B +, and the negative pole to GND, and set the voltage to 3.6V;

b. VM grounding, record the current passing through DC1 (Iq).

(6).Isd test method:

a. As shown in the figure7-6, connect the positive pole of DC1 to B + and the negative pole to GND, and set the voltage to 2V;

b. VM is suspended and the current passing through DC1 is recorded as Isd.

SCHEMATIC DIAGRAM OF TEST METHOD

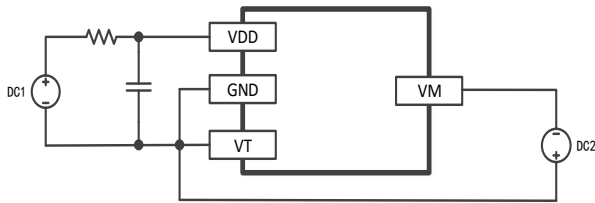

Figure7-1

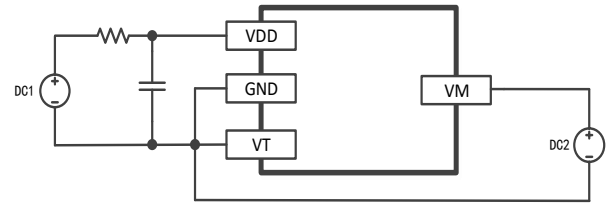

Figure7-2

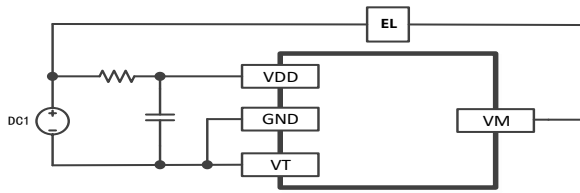

Figure7-3

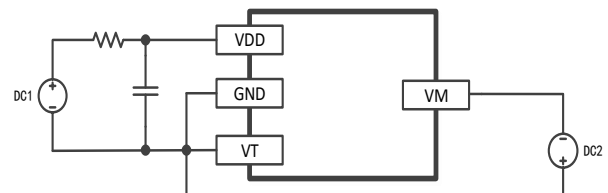

Figure7-4

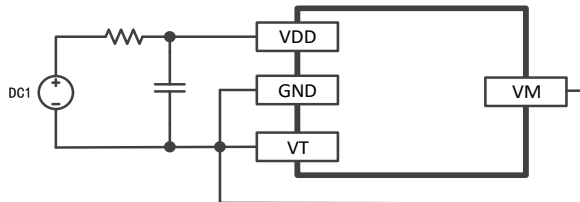

Figure7-5

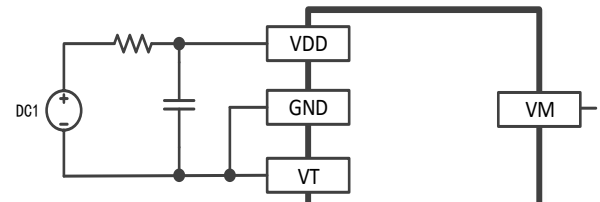
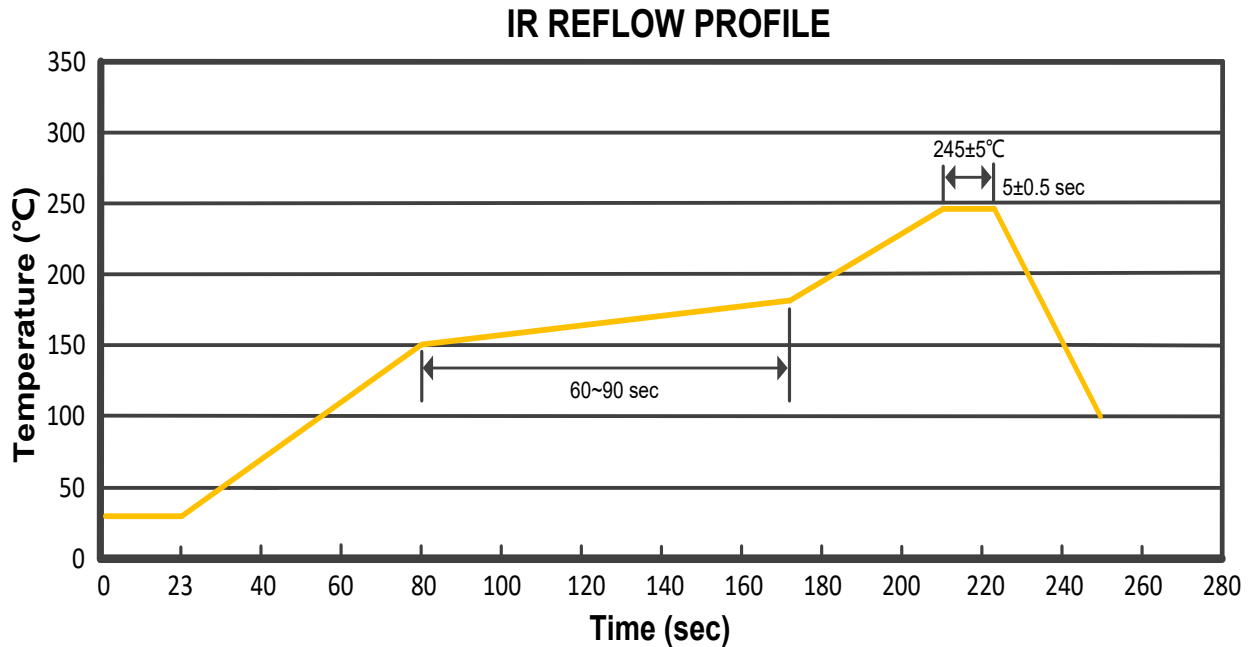

Figure7-6

Solderability Curve of Lead-Free Reflow Soldering (applicable to SMT tube)



Explain:

1. Preheating temperature 25~150°C, duration 60~90sec;
2. Peak temperature 245 ± 5 °C, duration 5 ± 0.5 sec;
3. Cooling rate of welding process is 2~10°C/sec.

Resistance to welding heat conditions

Temperature: 270 ± 5 °C; Time: 10 ± 1 sec

PACKAGE OUTLINE(DFN2x2-6)

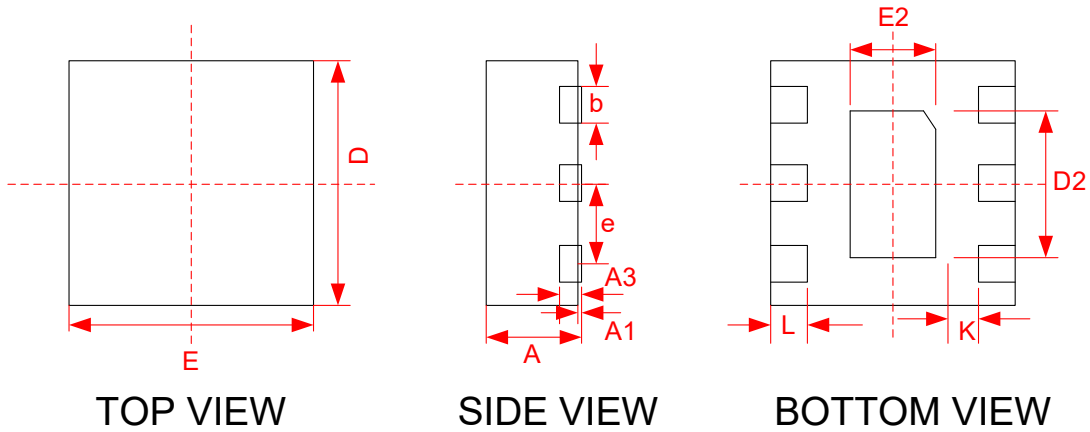

PACKAGE TYPE			
SYMBOLS	MIN	NOM	MAX
A		0.65	
A1	0.000	0.020	0.050
A3	0.20REF		
b	0.25	0.3	0.35
D	1.924	2.0	2.076
E	1.924	2.0	2.076
e	0.650 TYP		
L	0.224	0.30	0.376
K	0.20	-	-
E2	0.60	0.70	0.80
D2	1.10	1.20	1.30

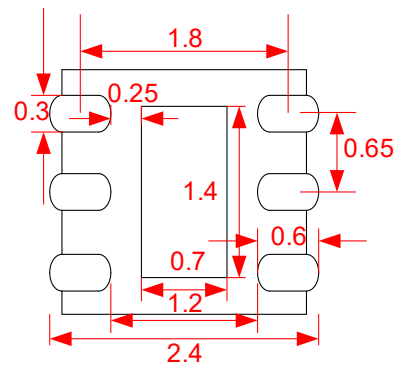

RECOMMENDED LAND PATTERN unit (mm)

DISCLAIMER

The information described herein is subject to change without notice.

Suzhou XySemi Electronic Technology Co., Limited is not responsible for any problems caused by circuits or diagrams described herein whose related industrial properties, patents, or other rights belong to third parties. The application circuit examples explain typical applications of the products, and do not guarantee the success of any specific mass-production design.

When the products described herein are regulated products subject to the Wassenaar Arrangement or other arrangements, they may not be exported without authorization from the appropriate governmental authority.

Use of the information described herein for other purposes and/or reproduction or copying without express permission of Suzhou XySemi Electronic Technology Co., Limited is strictly prohibited.

The products described herein cannot be used as part of any device or equipment affecting the human body, such as exercise equipment, medical equipment, security systems, gas equipment, or any apparatus installed in airplanes and other vehicles, without prior written permission of Suzhou XySemi Electronic Technology Co., Limited.

Although Suzhou XySemi Electronic Technology Co., Limited. exerts the greatest possible effort to ensure high quality and reliability, the failure or malfunction of semiconductor may occur. The use of these products should therefore give thorough

consideration to safety design, including redundancy, fire-prevention measure and malfunction prevention, to prevent any accidents, fires, or community damage that may ensue.

X-ON Electronics

Largest Supplier of Electrical and Electronic Components

Click to view similar products for [Battery Management](#) category:

Click to view products by [XySemi](#) manufacturer:

Other Similar products are found below :

[VN5R003HTR-E](#) [NCP1855FCCT1G](#) [FAN54063UCX](#) [LC05132C01NMTTTG](#) [ISL78714ANZ](#) [CM1104-EH](#) [CM1104-DBB](#) [CM1104-MBB](#)
[XC6801A421MR-G](#) [ISL95521BHRZ](#) [ISL95521BIRZ](#) [MP2639AGR-P](#) [S-82D1AAE-A8T2U7](#) [S-82D1AAA-A8T2U7](#) [S-8224ABA-I8T1U](#)
[MC33772CTC0AE](#) [BQ28Z610DRZR-R1](#) [MCP73832-4ADI/MC](#) [MCP73832T-2DCIMC](#) [MCP73833T-AMIMF](#) [MCP73833T-AMI/UN](#)
[MCP73838-NVI/MF](#) [MCP73213-A6BI/MF](#) [MCP73831-2ACI/MC](#) [MCP73831T-2ATIMC](#) [MCP73832-2ACI/MC](#) [MCP73832T-3ACIMC](#)
[MCP73833T-FCI/MF](#) [MCP73853-IML](#) [BQ25895RTWR](#) [BQ29704DSER](#) [BQ78Z100DRZR](#) [ISL78610ANZ](#) [FAN5403UCX](#)
[NCP367DPMUECTBG](#) [FAN54015BUCX](#) [MAX8934BETI+](#) [BQ24311DSGR](#) [BQ25100HYFPR](#) [BQ29707DSER](#) [MAX17048G+T10](#)
[BQ24130RHLLR](#) [BQ25120AYFPR](#) [BQ29703DSER](#) [BQ771807DPJR](#) [BQ25120AYFPT](#) [MAX17710GB+T](#) [MAX14634EWC+](#)
[BQ25121AYFPR](#) [BD99954GW-E2](#)