

# DATA SHEET

**Class 1, NP0 50/100/200/500 V  
Noble Metal Electrode  
Surface-mount ceramic  
multilayer capacitors**

Product specification  
Supersedes data of 11th September 2000

2001 Jul 16 Rev.6

## Surface-mount ceramic multilayer capacitors

## Class 1, NP0 50/100/200/500 V Noble Metal Electrode

### FEATURES

- Six standard sizes
- High capacitance per unit volume
- Supplied in tape on reel or in bulk case (case sizes 0402, 0603 and 0805 only)
- For high frequency applications
- NiSn terminations.

### APPLICATIONS

- Consumer electronics
- Telecommunications
- Automotive
- Data processing.

### DESCRIPTION

The capacitor consists of a rectangular block of ceramic dielectric in which a number of interleaved precious metal electrodes are contained. This structure gives rise to a high capacitance per unit volume.

The inner electrodes are connected to the two terminations, either by silver palladium (AgPd) alloy, or silver dipped with a barrier layer of plated nickel and finally covered with a layer of plated tin (NiSn). A cross section of the structure is shown in Fig.1.

### QUICK REFERENCE DATA

DESCRIPTION	VALUE
Rated voltage $U_R$ (DC)	50 V, 100 V, 200 V and 500 V (IEC)
Capacitance range (E12 series); note 1: 50 V; note 2 100 V 200 V 500 V	0.47 pF to 22 nF 10 pF to 22 nF 10 pF to 5.6 nF 10 pF to 3.3 nF
Tolerance on capacitance: $C \geq 10$ pF $C < 10$ pF	$\pm 5\%$ ; $\pm 2\%$ $\pm 0.5$ pF; $\pm 0.25$ pF
Test voltage (DC) for 1 minute: 50 V and 100 V 200 V 500 V	$2.5 \times U_R$ $3 \times U_R$ $2 \times U_R$
Sectional specifications	IEC 60384-10, second edition 1989-04; also based on CECC 32 100
Detailed specification	based on CECC 32 101-801
Climatic category (IEC 60068)	55/125/56

### Notes

1. Other values below 10 pF and non E12 series are available on request.
2. Also applicable for applications up to 63 V.

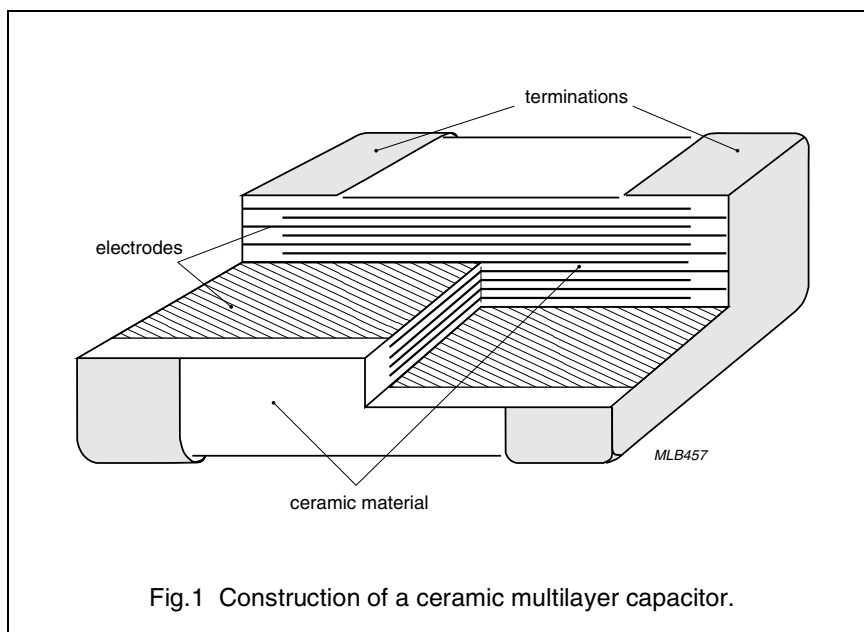

# Surface-mount ceramic multilayer capacitors

# Class 1, NP0 50/100/200/500 V Noble Metal Electrode

## MECHANICAL DATA

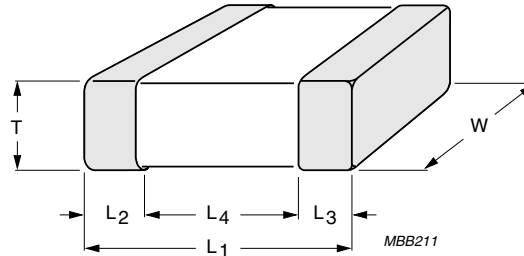

For dimensions see Table 1.

Fig.2 Component outline.

## Physical dimensions

Table 1 Capacitor dimensions

CASE SIZE	L <sub>1</sub>	W	T		L <sub>2</sub> and L <sub>3</sub>		L <sub>4</sub> MIN.
			MIN.	MAX.	MIN.	MAX.	
<b>Dimensions in millimetres</b>							
0402	1.0 ±0.05	0.5 ±0.05	0.45	0.55	0.20	0.30	0.40
0603	1.6 ±0.10	0.8 ±0.07	0.73	0.87	0.25	0.65	0.40
0805	2.0 ±0.10	1.25 ±0.10	0.50	1.35	0.25	0.75	0.55
1206	3.2 ±0.15	1.6 ±0.15	0.50	1.75	0.25	0.75	1.40
1210	3.2 ±0.20	2.5 ±0.20	0.50	1.80	0.25	0.75	1.40
1812	4.5 ±0.20	3.2 ±0.20	0.50	1.80	0.25	0.75	2.20
<b>Dimensions in inches</b>							
0402	0.040 ±0.002	0.020 ±0.002	0.018	0.022	0.008	0.012	0.016
0603	0.063 ±0.004	0.032 ±0.003	0.029	0.035	0.010	0.026	0.016
0805	0.079 ±0.004	0.049 ±0.004	0.020	0.053	0.010	0.030	0.022
1206	0.126 ±0.006	0.063 ±0.006	0.020	0.069	0.010	0.030	0.056
1210	0.126 ±0.008	0.098 ±0.008	0.020	0.072	0.010	0.030	0.056
1812	0.177 ±0.008	0.126 ±0.008	0.020	0.072	0.010	0.030	0.088

# Surface-mount ceramic multilayer capacitors

# Class 1, NP0 50 V Noble Metal Electrode

## SELECTION CHART FOR 50 V

C (pF)	LAST THREE DIGITS OF 12NC	50 V					
		0402	0603	0805	1206	1210	1812
0.47	477						
0.56	567						
0.68	687						
0.82	827						
1.0	108						
1.2	128						
1.5	158						
1.8	188						
2.2	228						
2.7	278						
3.3	338						
3.9	398						
4.7	478						
5.6	568						
6.8	688						
8.2	828						
10	109	0.5 ±0.05					
12	129						
15	159						
18	189		0.8 ±0.07				
22	229						
27	279						
33	339			0.6 ±0.1			
39	399						
47	479						
56	569				0.6 ±0.1		
68	689						
82	829						
100	101						
120	121						
150	151						
180	181						
220	221						
270	271						
330	331						
390	391						
470	471						
560	561						
680	681						
820	821					0.5 to 1.0	
1000	102						
1200	122						
1500	152			0.85 ±0.1			
1800	182						
2200	222			1.25 ±0.1			0.5 to 1.0
2700	272						
3300	332						
3900	392				0.85 ±0.1		
4700	472						
5600	562				1.15 ±0.1		
6800	682						
8200	822						
10000	103						
12000	123						

# Surface-mount ceramic multilayer capacitors

# Class 1, NP0 50 V Noble Metal Electrode

C (pF)	LAST THREE DIGITS OF 12NC	50 V					
		0402	0603	0805	1206	1210	1812
15000	153						0.5 to 1.0
18000	183						0.9 to 1.3
22000	223						

### Note

1. Values in shaded cells indicate thickness class.

### Thickness classification and packing quantities

THICKNESS CLASSIFICATION (mm)	8 mm TAPE WIDTH QUANTITY PER REEL				12 mm TAPE WIDTH QUANTITY PER REEL	QUANTITY PER BULK CASE		
	Ø180 mm; 7"		Ø330 mm; 13"		Ø180 mm; 7" BLISTER	0402	0603	0805
	PAPER	BLISTER	PAPER	BLISTER	1812			
0.5 ±0.05	10000	–	50000	–	–	50000	–	–
0.6 ±0.1	4000	–	20000	–	–	–	–	10000
0.8 ±0.07	4000	–	15000	–	–	–	15000	–
0.85 ±0.1	4000	–	15000	–	–	–	–	8000
0.5 to 1.0	–	4000	–	10000	2000	–	–	–
0.9 to 1.3	–	3000	–	10000	1500	–	–	–
1.15 ±0.1	–	3000	–	10000	–	–	–	–
1.25 ±0.1	–	3000	–	10000	–	–	–	5000

Surface-mount ceramic  
multilayer capacitors

Class 1, NP0 50 V  
Noble Metal Electrode

**ORDERING INFORMATION FOR 50 V**

Components may be ordered by using either a simple 15-digit clear text code or Phycomp's unique 12NC.

**Clear text code**

EXAMPLE: 0805CG102J9B200

SIZE CODE	TEMP. CHAR.	CAPACITANCE	TOL.	VOLTAGE	TERMINATION	PACKING	MARKING	SERIES
0402 0603 0805 1206 1210 1812	CG = NP0	102 = 1000 pF; the third digit signifies the multiplying factor: 8 = × 0.01 9 = × 0.1 0 = × 1 1 = × 10 2 = × 100 3 = × 1000	C = ±0.25 pF D = ±0.5 pF G = ±2% J = ±5%	9 = 50 V	B = NiSn	2 = 180 mm; 7" paper 3 = 330 mm; 13" paper B = 180 mm; 7" blister F = 330 mm; 13" blister P = bulk case	0 = no marking	0 = conv. ceramic

**Ordering code 12NC**

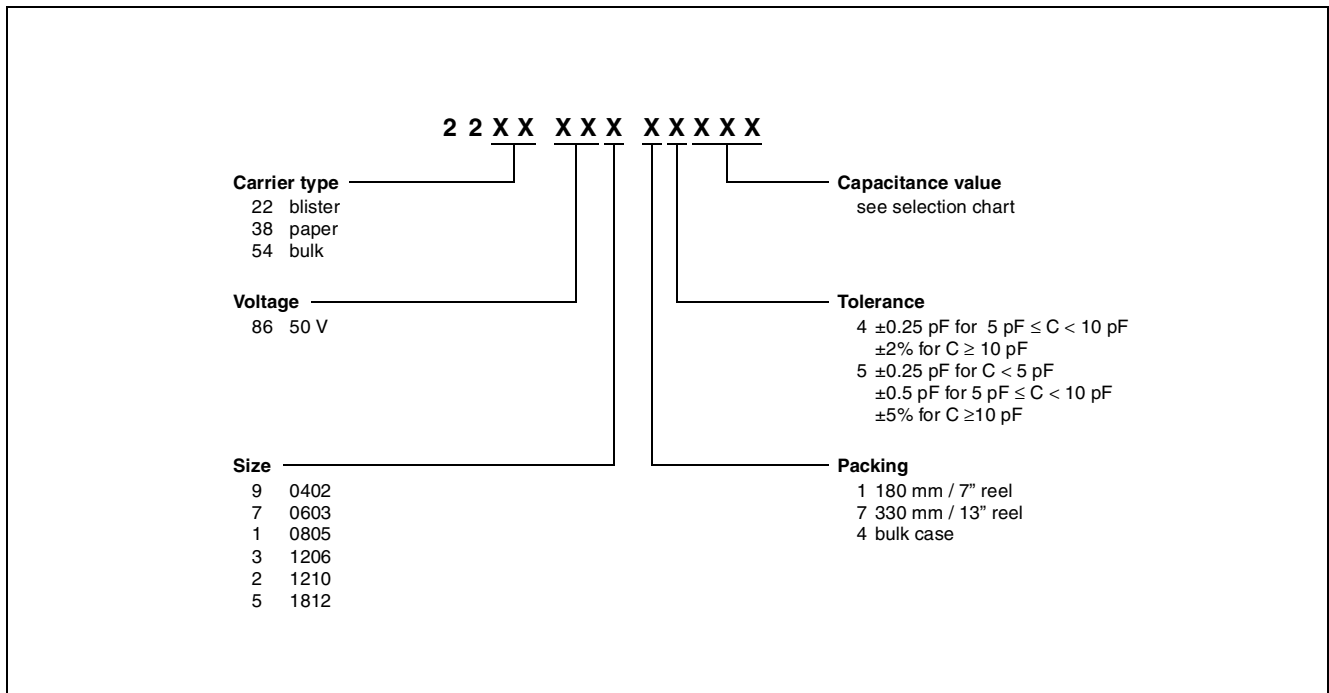

# Surface-mount ceramic multilayer capacitors

# Class 1, NP0 100 V Noble Metal Electrode

## SELECTION CHART FOR 100 V

C (pF)	LAST TWO DIGITS OF 12NC	100 V				
		0603	0805	1206	1210	1812
10	23					
12	24					
15	25					
18	26					
22	27					
27	28					
33	29					
39	31					
47	32					
56	33					
68	34					
82	35	0.8 ±0.07				
100	36					
120	37		0.6 ±0.1			
150	38					
180	39					
220	41			0.6 ±0.1		
270	42					
330	43					
390	44					
470	45					
560	46					
680	47					
820	48					
1000	49					
1200	51					
1500	52		0.85 ±0.1			
1800	53					
2200	54		1.25 ±0.1			
2700	55					
3300	56					
3900	57			0.85 ±0.1		
4700	58					
5600	59			1.15 ±0.1		
6800	61					
8200	62				0.5 to 1.0	
10000	63					
12000	64					0.5 to 1.0
15000	65					
18000	66					0.9 to 1.3
22000	67					

### Note

1. Values in shaded cells indicate thickness class.

Surface-mount ceramic  
multilayer capacitors

Class 1, NP0 100 V  
Noble Metal Electrode

Thickness classification and packing quantities

THICKNESS CLASSIFICATION (mm)	8 mm TAPE WIDTH QUANTITY PER REEL				12 mm TAPE WIDTH QUANTITY PER REEL	QUANTITY PER BULK CASE	
	Ø180 mm; 7"		Ø330 mm; 13"		Ø180 mm; 7" BLISTER	0603	0805
	PAPER	BLISTER	PAPER	BLISTER	1812		
0.6 ±0.1	4000	–	20000	–	–	–	10000
0.8 ±0.07	4000	–	15000	–	–	15000	–
0.85 ±0.1	4000	–	15000	–	–	–	8000
0.5 to 1.0	–	4000	–	10000	2000	–	–
0.9 to 1.3	–	3000	–	10000	1500	–	–
1.15 ±0.1	–	3000	–	10000	–	–	–
1.25 ±0.1	–	3000	–	10000	–	–	5000

ORDERING INFORMATION FOR 100 V

Components may be ordered by using either a simple 15-digit clear text code or Phycomp's unique 12NC.

Clear text code

EXAMPLE: 0805CG102G0B200

SIZE CODE	TEMP. CHAR.	CAPACITANCE	TOL.	VOLTAGE	TERMINATION	PACKING	MARKING	SERIES
0603	CG = NP0	102 = 1000 pF; the third digit signifies the multiplying factor: 0 = × 1 1 = × 10 2 = × 100 3 = × 1000	G = ±2% J = ±5%	0 = 100 V	B = NiSn	2 = 180 mm; 7" paper 3 = 330 mm; 13" paper B = 180 mm; 7" blister F = 330 mm; 13" blister P = bulk case	0 = no marking	0 = conv. ceramic

Ordering code 12NC

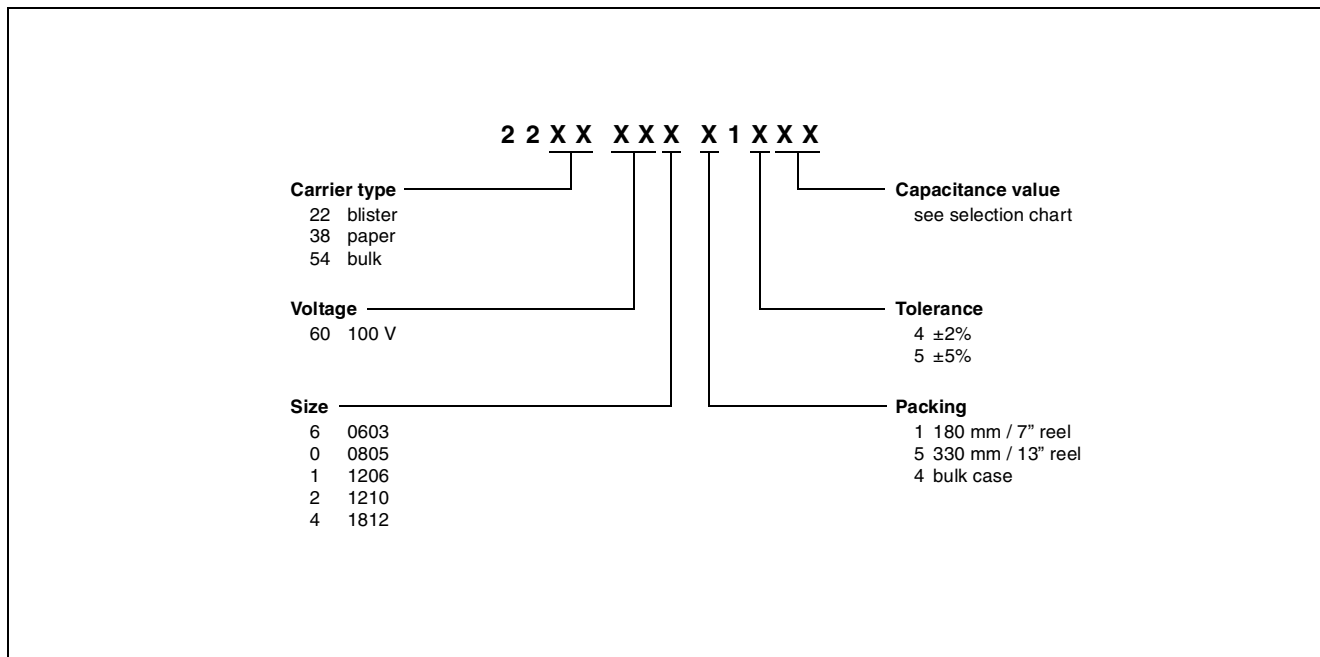



# Surface-mount ceramic multilayer capacitors

# Class 1, NP0 200 V and 500 V Noble Metal Electrode

## SELECTION CHART FOR 200 V AND 500 V

C (pF)	LAST TWO DIGITS OF 12NC	200 V				500 V		
		0805	1206	1210	1812	1206	1210	1812
10	23							
12	24							
15	25							
18	26							
22	27							
27	28							
33	29							
39	31							
47	32	0.6 ±0.1				0.6 ±0.1		
56	33							
68	34		0.6 ±0.1					
82	35							
100	36							
120	37							
150	38							
180	39							
220	41						0.8 to 1.0	
270	42							
330	43	0.85 ±0.1				0.85 ±0.1		
390	44							
470	45		0.85 ±0.1					
560	46	1.25 ±0.1						
680	47					1.15 ±0.1		
820	48							
1000	49							
1200	51						0.9 to 1.3	
1500	52		1.15 ±0.1					
1800	53			0.8 to 1.0			1.2 to 1.75	
2200	54							
2700	55			0.9 to 1.3				0.9 to 1.3
3300	56							
3900	57				0.8 to 1.0			
4700	58				0.9 to 1.3			
5600	59							

### Note

- Values in shaded cells indicate thickness class.

### Thickness classification and packing quantities

THICKNESS CLASSIFICATION (mm)	8 mm TAPE WIDTH QUANTITY PER REEL				12 mm TAPE WIDTH QUANTITY PER REEL	QUANTITY PER BULK CASE
	Ø180 mm; 7"		Ø330 mm; 13"		Ø180 mm; 7" BLISTER	
	PAPER	BLISTER	PAPER	BLISTER	1812	0805
0.6 ±0.1	4000	–	20000	–	–	10000
0.85 ±0.1	4000	–	15000	–	–	8000
0.8 to 1.0	–	4000	–	10000	2000	–
0.9 to 1.3	–	3000	–	10000	1500	–
1.15 ±0.1	–	3000	–	10000	–	–
1.25 ±0.1	–	3000	–	10000	–	5000
1.2 to 1.75	–	2500	–	10000	1200	–

## Surface-mount ceramic multilayer capacitors

## Class 1, NP0 200 V and 500 V Noble Metal Electrode

### ORDERING INFORMATION FOR 200 V AND 500 V

Components may be ordered by using either a simple 15-digit clear text code or Phycomp's unique 12NC.

#### Clear text code

EXAMPLE: 1206CG102GBB200

SIZE CODE	TEMP. CHAR.	CAPACITANCE	TOL.	VOLTAGE	TERMINATION	PACKING	MARKING	SERIES
0805 1206 1210 1812	CG = NP0	102 = 1 000 pF; the third digit signifies the multiplying factor: 0 = × 1 1 = × 10 2 = × 100 3 = × 1 000	G = ±2% J = ±5%	B = 200 V D = 500 V	B = NiSn	2 = 180 mm; 7" paper 3 = 330 mm; 13" paper B = 180 mm; 7" blister F = 330 mm; 13" blister P = bulk case	0 = no marking	0 = conv. ceramic

#### Ordering code 12NC

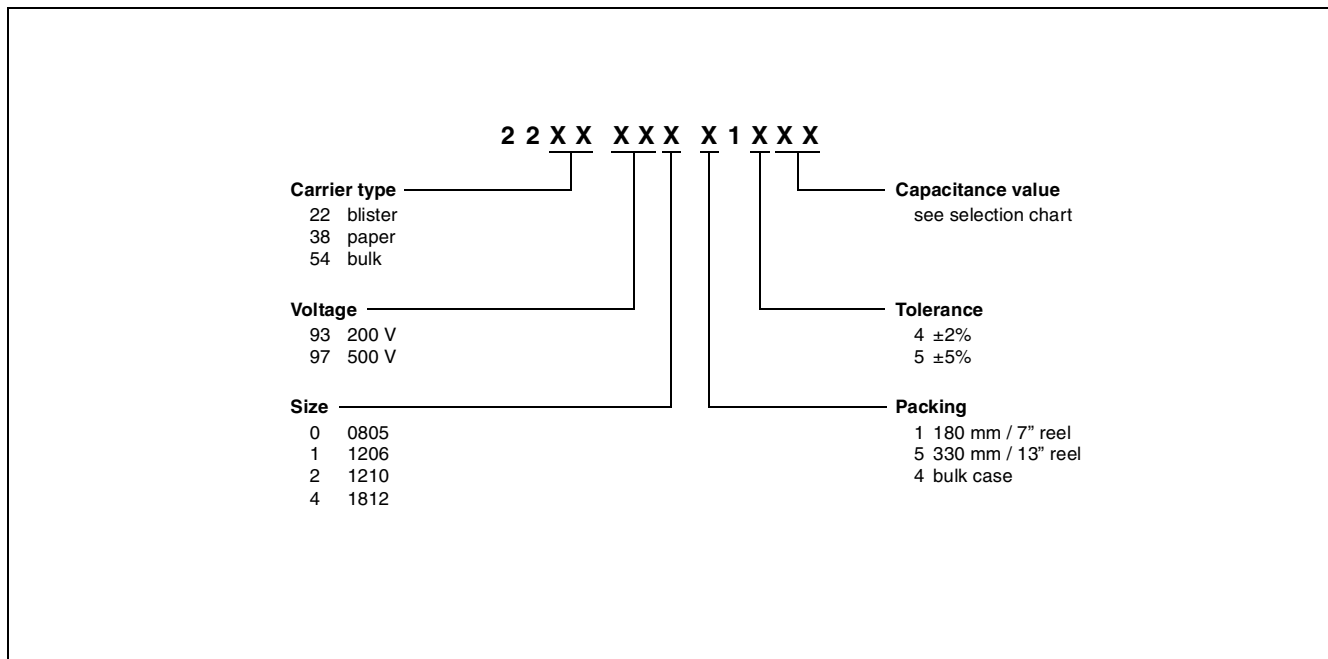

## Surface-mount ceramic multilayer capacitors

## Class 1, NP0 50/100/200/500 V Noble Metal Electrode

### ELECTRICAL CHARACTERISTICS

#### Class 1 capacitors; NP0 dielectric; NiSn terminations

Unless otherwise stated all electrical values apply at an ambient temperature of  $20 \pm 1$  °C, an atmospheric pressure of 86 to 106 kPa, and a relative humidity of 63 to 67%.

DESCRIPTION	VALUE
Capacitance range (E12 series); note 1: 50 V 100 V 200 V 500 V	0.47 pF to 22 nF 10 pF to 22 nF 10 pF to 5.6 nF 10 pF to 3.3 nF
Tolerance on capacitance after 1000 hours: $C \geq 10$ pF $5 \text{ pF} \leq C < 10$ pF $C < 5$ pF	$\pm 5\%$ ; $\pm 2\%$ $\pm 0.5$ pF, $\pm 0.25$ pF $\pm 0.25$ pF
Tan $\delta$ ; note 1: $C < 10$ pF $C \geq 10$ pF	$\leq 10 \left( \frac{3}{C} + 0.7 \right) \times 10^{-4}$ or $30 \times 10^{-4}$ , whichever is smallest $\leq 10 \times 10^{-4}$
Insulation resistance after 1 minute at $U_R$ (DC)	$R_{\text{ins}} > 100 \text{ G}\Omega$
Temperature coefficient: $C < 10$ pF $C \geq 10$ pF	$(0 \pm 150) \times 10^{-6}/\text{K}$ ; note 2 $(0 \pm 30) \times 10^{-6}/\text{K}$ ; note 2
Ageing	not applicable

#### Notes

1. Measured at 1 V, 1 MHz for  $C \leq 1000$  pF and 1 V, 1 kHz for  $C > 1000$  pF, using a four-gauge method.
2. For sizes 0402 and 0603 all capacitance values from 0.47 pF to 150 pF have a temperature coefficient of  $(0 \pm 30) \times 10^{-6}/\text{K}$ .

Surface-mount ceramic  
multilayer capacitors

Class 1, NP0 50/100/200/500 V  
Noble Metal Electrode

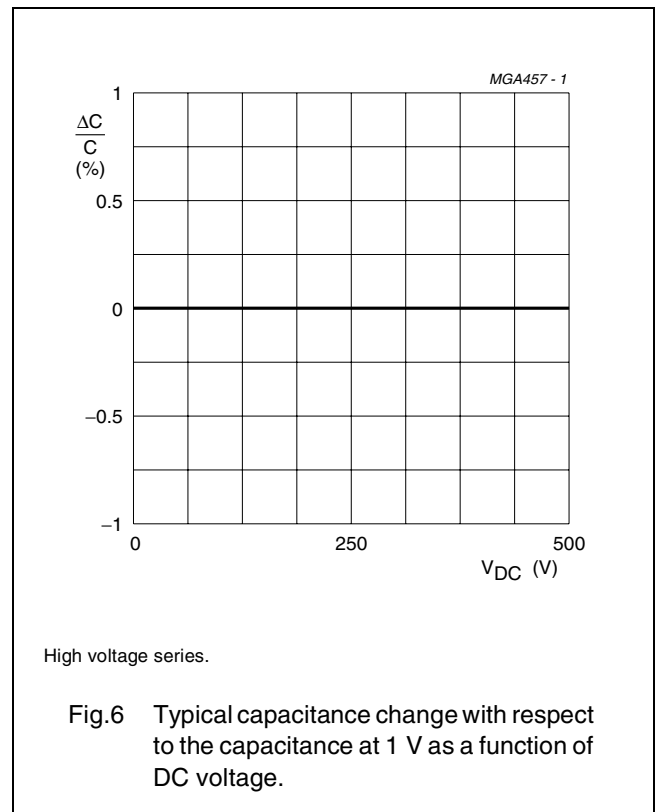
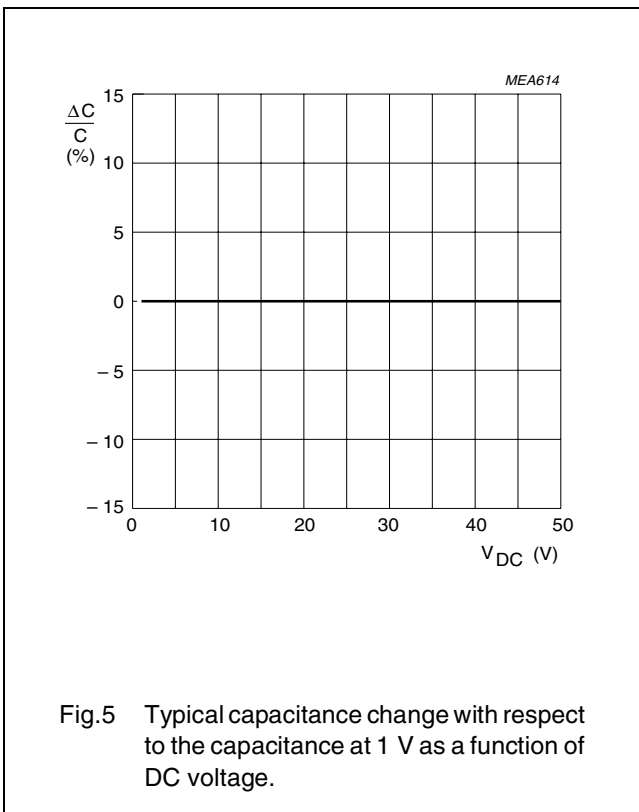
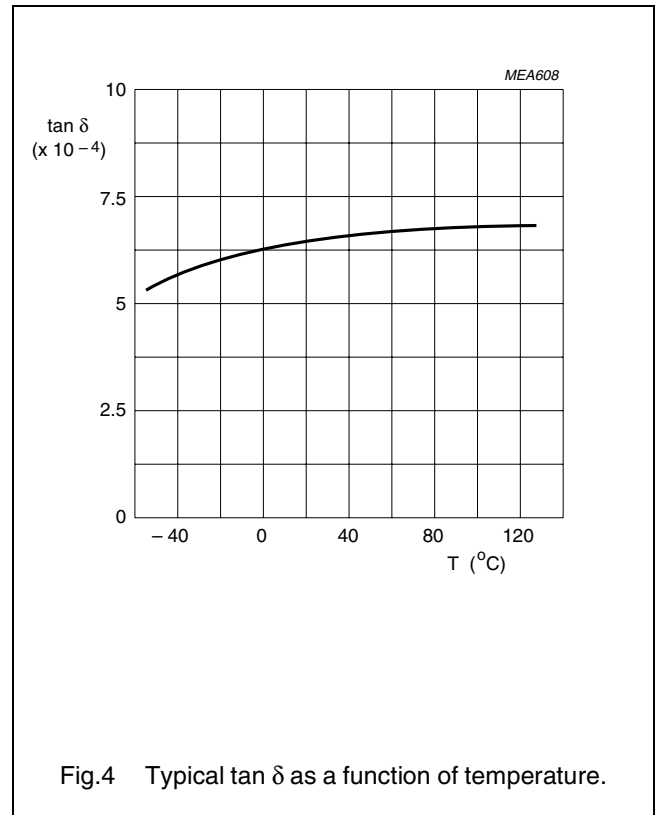
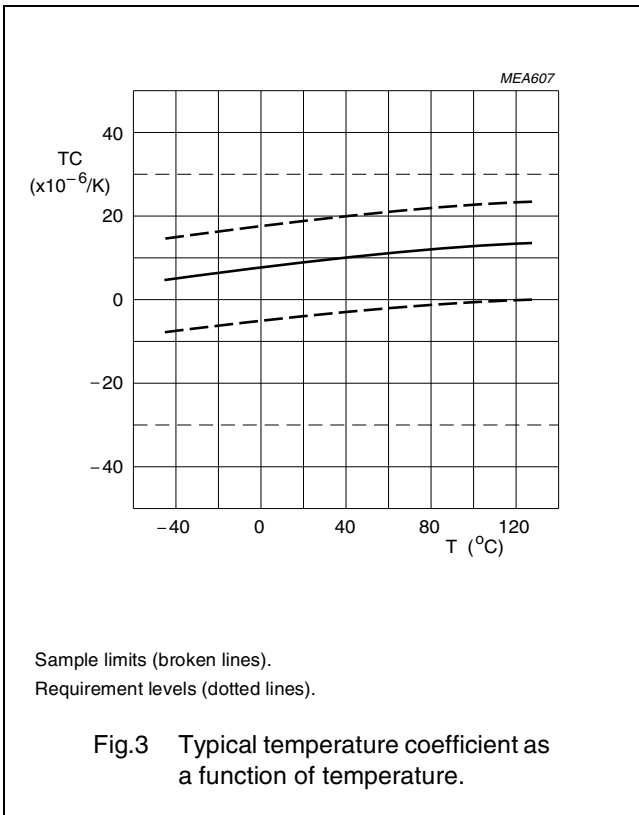

Surface-mount ceramic multilayer capacitors

Class 1, NP0 50/100/200/500 V Noble Metal Electrode

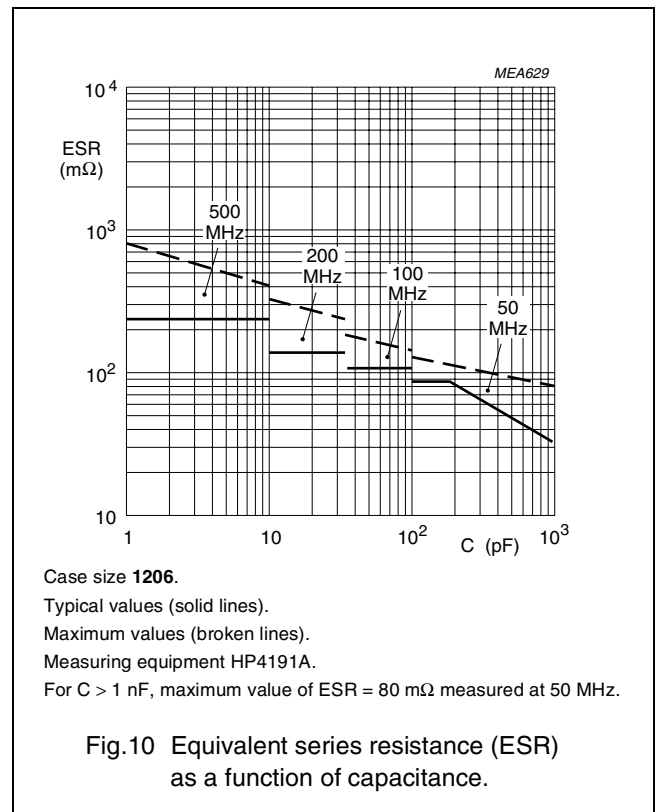
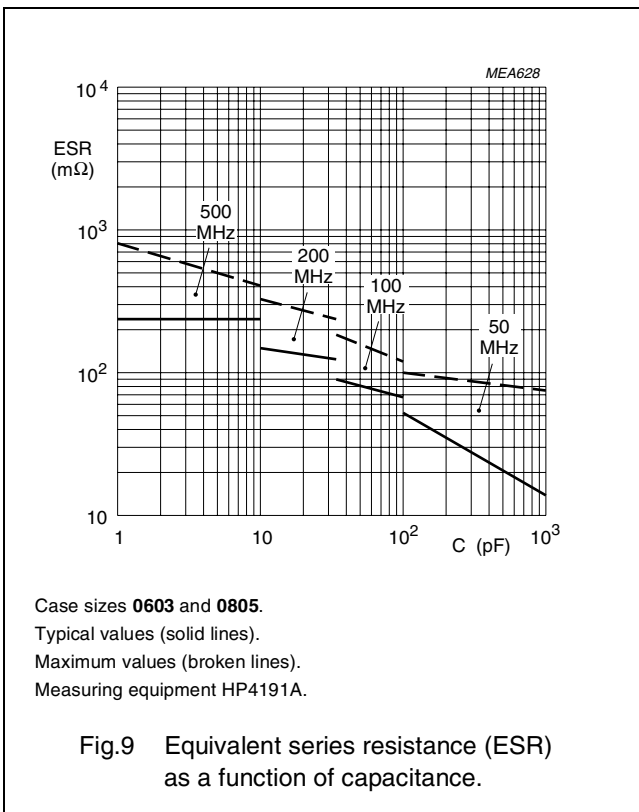
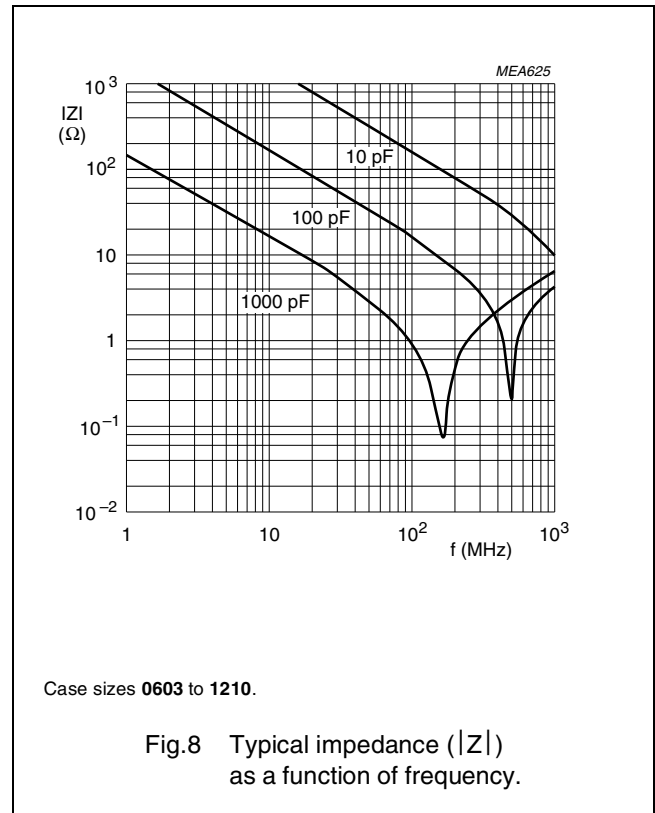
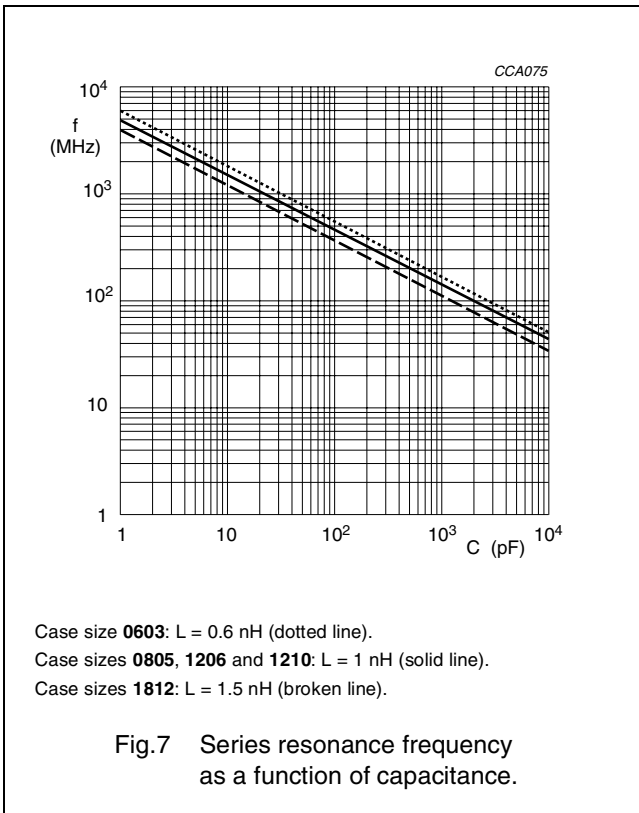

Surface-mount ceramic multilayer capacitors

Class 1, NP0 50/100/200/500 V Noble Metal Electrode

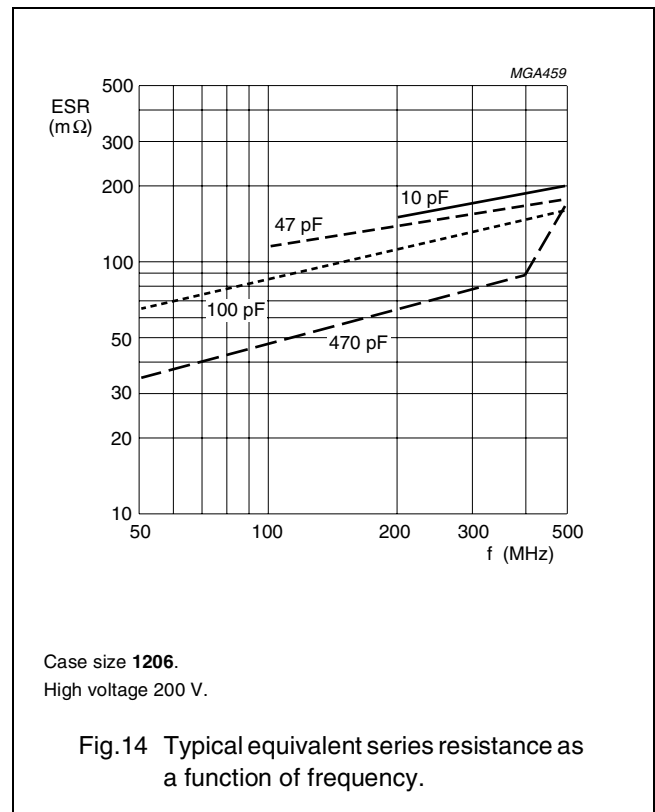
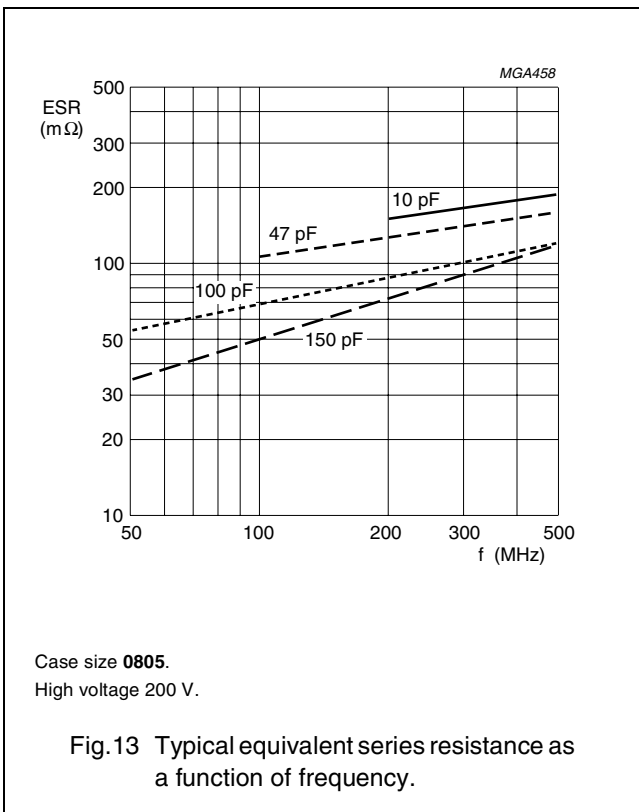
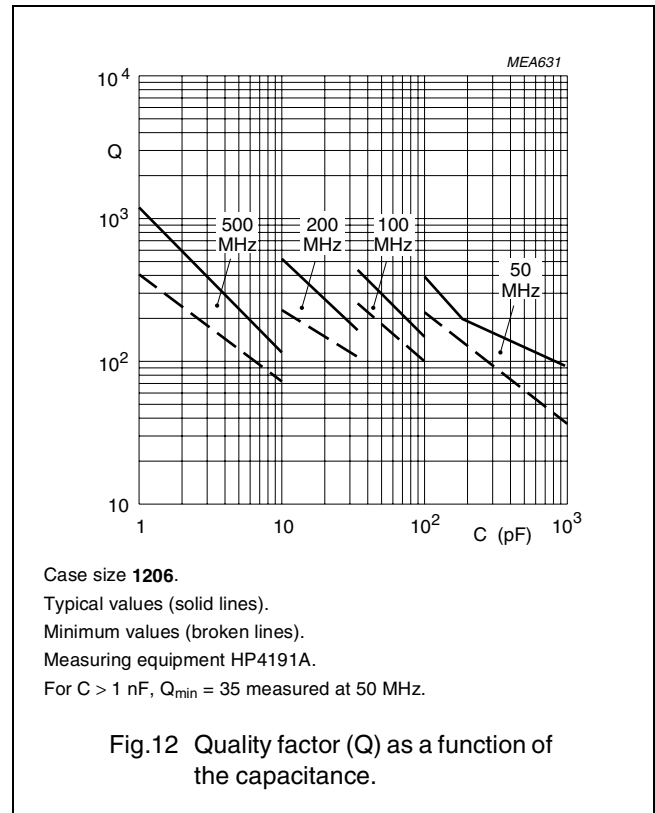
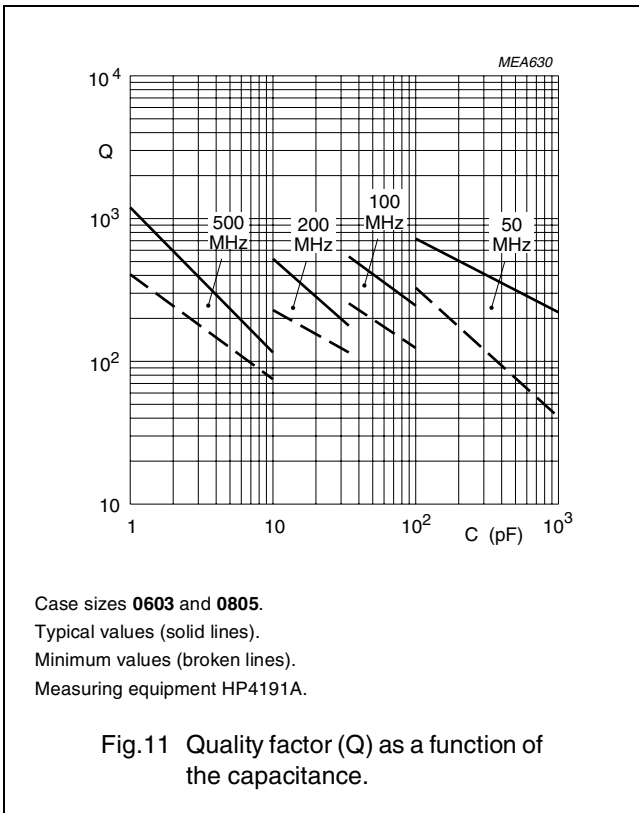

## Surface-mount ceramic multilayer capacitors

## Class 1, NP0 50/100/200/500 V Noble Metal Electrode

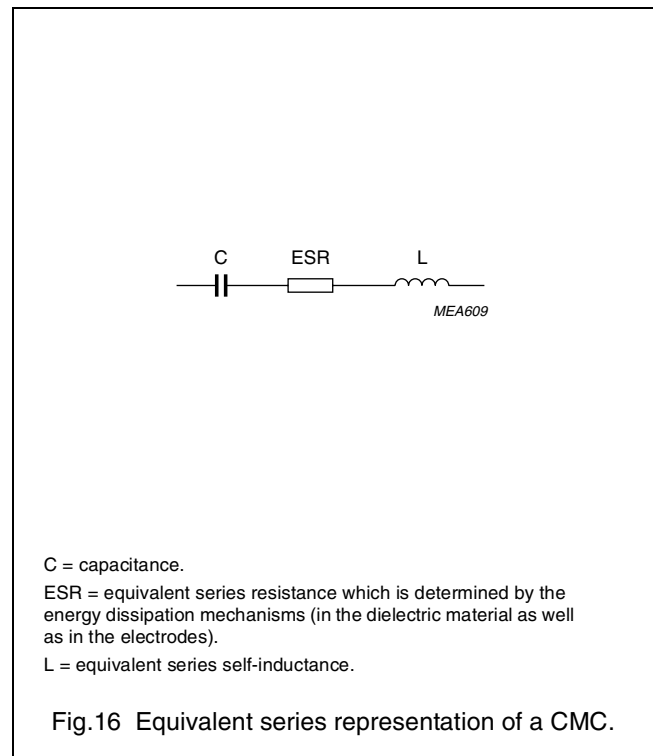
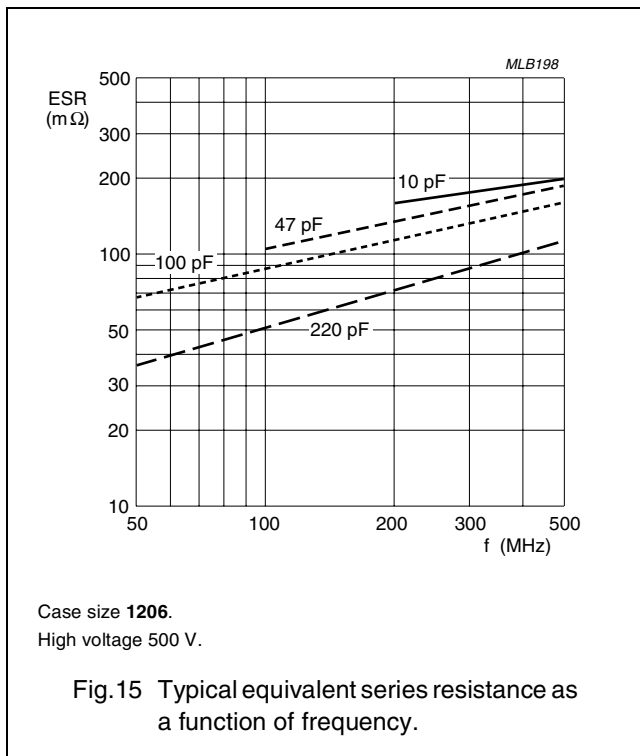

### HIGH FREQUENCY BEHAVIOUR OF CERAMIC MULTILAYER CAPACITORS

Ceramic multilayer capacitors (CMC) are suitable for use at high frequencies. At frequencies below the series resonance frequency, the CMC can be represented by an equivalent circuit as shown in Fig.16.

In general, the quantities C, ESR and L are frequency dependent. For most applications, C and L can be regarded as frequency independent below 1 GHz.

The equivalent series self-inductance L is:

- Independent of the dielectric material.
- Dependent on the size of the capacitor, it increases with increasing length and decreases with increasing width or thickness of the product.
- The value of L is approximately:
  - 0.6 nH for case size 0603
  - 1 nH for case sizes 0805, 1206 and 1210
  - 1.5 nH for case size 1812.

These figures are accurate to within 20%.

Because of the inductance L, associated with the CMC, there will be a frequency at which the inductive reactance will be equal to the reactance of the capacitor.

This is known as the series resonance frequency (SRF) and is given by:

$$SRF = \frac{1}{2\pi\sqrt{LC}}$$

At the SRF, the CMC will appear as a small resistor. The transmission loss through the CMC at this series resonance frequency will be low.

Using the values of C, L = 1 nH and the ESR at a specific frequency (f), two often used quantities can be derived.

The impedance (Z) is given by:

$$Z = \frac{1 - (2\pi f)^2 LC}{2j\pi f C} + ESR$$

The quality factor (Q) is given by:

$$Q = \frac{|1 - (2\pi f)^2 LC|}{2\pi f ESR C}$$

---

Surface-mount ceramic  
multilayer capacitors

---

Class 1, NP0 50/100/200/500 V  
Noble Metal Electrode

---

**REVISION HISTORY**

Revision	Date	Change Notification	Description
Rev.6	2001 Jul 16	–	<ul style="list-style-type: none"><li>- Converted to Phycomp brand</li><li>- Highest value in 50 V range reduced from 47 nF to 33 nF</li><li>- Various thickness classes corrected</li><li>- Products in 2020 case size removed</li><li>- AgPd finishing for terminations no longer supported</li></ul>



## X-ON Electronics

Largest Supplier of Electrical and Electronic Components

*Click to view similar products for [Multilayer Ceramic Capacitors MLCC - SMD/SMT](#) category:*

*Click to view products by [Yageo](#) manufacturer:*

Other Similar products are found below :

[M39014/01-1467](#) [M39014/02-1218V](#) [M39014/02-1225V](#) [M39014/02-1262V](#) [M39014/02-1301](#) [M39014/22-0631](#) [1210J5000102JCT](#)  
[1210J2K00102KXT](#) [1210J5000103KXT](#) [1210J5000223KXT](#) [D55342E07B379BR-TR](#) [D55342E07B523DR-T/R](#) [1812J1K00103KXT](#)  
[1812J1K00473KXT](#) [1812J2K00680JCT](#) [1812J4K00102MXT](#) [1812J5000102JCT](#) [1812J5000103JCT](#) [1812J5000682JCT](#) [NIN-FB391JTRF](#)  
[NIN-FC2R7JTRF](#) [NPIS27H102MTRF](#) [C1206C101J1GAC](#) [C1608C0G1E472JT000N](#) [C2012C0G2A472J](#) [CA050M0047REH-0607](#)  
[2220J2K00101JCT](#) [KHC201E225M76N0T00](#) [1812J1K00222JCT](#) [1812J2K00102KXT](#) [1812J2K00222KXT](#) [1812J2K00472KXT](#) [2-1622820-](#)  
[7-CUT-TAPE](#) [2220J3K00102KXT](#) [2225J2500824KXT](#) [CCR07CG103KM](#) [CGA2B2C0G1H010C](#) [CGA2B2C0G1H040C](#)  
[CGA2B2C0G1H050C](#) [CGA2B2C0G1H060D](#) [CGA2B2C0G1H070D](#) [CGA2B2C0G1H151J](#) [CGA2B2C0G1H1R5C](#) [CGA2B2C0G1H2R2C](#)  
[CGA2B2C0G1H3R3C](#) [CGA2B2C0G1H680J](#) [CGA2B2C0G1H6R8D](#) [CGA2B2X8R1H221K](#) [CGA2B2X8R1H472K](#) [CGA3E1X7R1C474K](#)