

## Transient Voltage Suppressors (TVS) Data Sheet

### Features

- Glass passivated junction
- Low inductance
- Excellent clamping capability
- 10000W peak pulse power capability at 10/1000µs waveform, repetition rate (duty cycle): 0.05%
- Fast response time
- High Temperature soldering guaranteed: 265°C/10 seconds/.375", (9.5mm) lead length, 5lbs (2.3kg) tension
- Plastic package has underwriters laboratory flammability 94V-0
- Meets MSL level 1, per J-STD-020
- IEC61000-4-2 ESD 30KV Air, 30KV contact compliance



### Mechanical Data

- Case: Moulded plastic over glass passivated junction
- Terminal: Plated Axial leads, solderable per MIL-STD-750, Method 2026
- Mounting Position: Any
- Weight: 2.75g

### Applications

- I/O interface
- AC/DC power supply
- Low frequency signal transmission line (RS232, RS485, etc.)
- Meets ISO7637-2 surge spec.

### Maximum Ratings and Characteristics

Ratings at 25°C ambient temperature unless otherwise specified.

Rating	Symbol	Value	Units
Peak pulse power dissipation at 10/1000µs waveform (Note1, Fig.2)	$P_{PPM}$	Minimum 10000	Watts
Peak pulse current of at 10/1000µs waveform (Note 1, Fig.3)	$I_{PPM}$	See Table	Amps
Steady state power dissipation at $T_L=75^\circ\text{C}$ (Fig.5)	$P_{M(AV)}$	8.0	Watts
Peak forward surge current, 8.3ms single half sine-wave superimposed on rated load, (JEDEC Method) (Note2, Fig.6)	$I_{FSM}$	300	Amps
Operating junction and Storage Temperature Range.	$T_J, T_{STG}$	-55 to +150	°C
Typical thermal resistance junction to lead	$R_{\theta JL}$	8	°C/W
Typical thermal resistance junction to ambient	$R_{\theta JA}$	40	°C/W

Notes: 1. Non-repetitive current pulse, per Fig.3 and derated above  $T_A=25^\circ\text{C}$  per Fig.2.

2. 8.3ms single half sine-wave, or equivalent square wave, duty cycle=4 pulses per minutes maximum.

**Dimensions (P600)**

Symbol	Millimeters		Inches	
	Min.	Max.	Min.	Max.
L	25.40	-	1.000	-
T	8.60	9.10	0.340	0.360
d	8.60	9.10	0.340	0.360
s	1.19	1.32	0.047	0.052

**Electrical Characteristics (T<sub>A</sub>=25°C)**

Part Number		Type ①	Breakdown Voltage @I <sub>T</sub>		Test Current I <sub>T</sub> (mA)	Reverse Stand-Off Voltage V <sub>RWM</sub> (V)	Reverse Leakage @ V <sub>RWM</sub> I <sub>R</sub> (µA)	Maximum Clamping Voltage @I <sub>PP</sub> V <sub>C</sub> (V)	Peak Pulse Current I <sub>PP</sub> (A)
Unidirectional	Bidirectional		V <sub>BR</sub> MIN.(V)	V <sub>BR</sub> MAX.(V)					
ATS22A	ATS22C	2CF	24.2	26.9	5	22	1.8	35.5	287
ATS24A	ATS24C	2CF	26.7	29.6	5	24	1.8	39	257
ATS26A	ATS26C	2CF	28.9	32	5	26	1.8	42.1	237
ATS28A	ATS28C	2CF	31.1	34.5	5	28	1.8	45.4	220
ATS30A	ATS30C	2CF	33	38	5	30	1.8	50	250
ATS33A	ATS33C	2CF	36.7	40.6	5	33	1.8	53	190
ATS36A	ATS36C	2CF	40	44.2	5	36	1.8	58.1	174
ATS40A	ATS40C	2CF	44.4	49.1	5	40	1.8	64.5	155

Part Number		Type ①	Suitable ISO 7637-2 2004 5a test waveform									
Unidirectional	Bidirectional		V <sub>C</sub> (V)	Maximum Clamping Voltage	Voltage level			Resistance Level				
		87V 400mS		174V 350mS	DC(V)	0.5Ω	1Ω	2Ω	3Ω	4Ω	8Ω	
ATS22A	ATS22C	2CF	35.5	x	--	13.5	--	x	x	x	x	x
ATS24A	ATS24C	2CF	39	x	--	13.5	--	x	x	x	x	x
ATS26A	ATS26C	2CF	42.1	x	--	27	--	--	--	--	x	x
ATS28A	ATS28C	2CF	45.4	x	--	27	--	--	--	--	x	x
ATS30A	ATS30C	2CF	50	--	x	28	--	--	--	--	x	x
ATS33A	ATS33C	2CF	53	--	x	28	--	--	--	--	x	x
ATS36A	ATS36C	2CF	58.1	--	x	28	--	--	--	--	x	x
ATS40A	ATS40C	2CF	64.5	--	x	28	--	--	--	--	x	x

Note: 'x' representatives meets this test condition;

**Ratings and Characteristic Curves ( $T_A=25^\circ\text{C}$  unless otherwise noted)**

**Figure 1. ISO 7637-2 5a Test pulse**

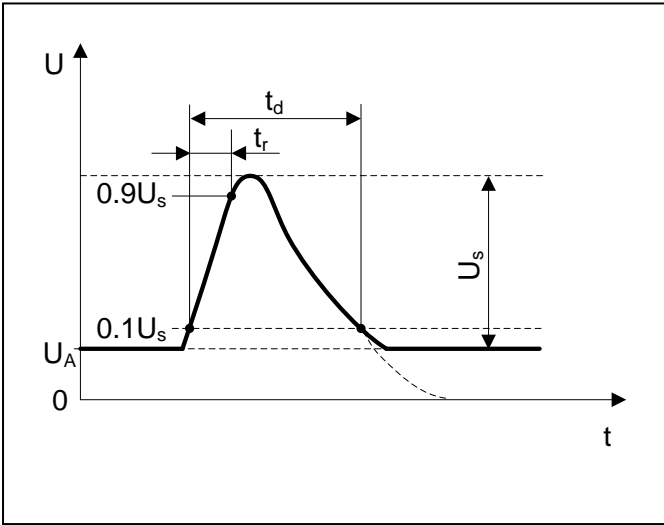

**Figure 2. Peak Pulse Power Rating Curve**

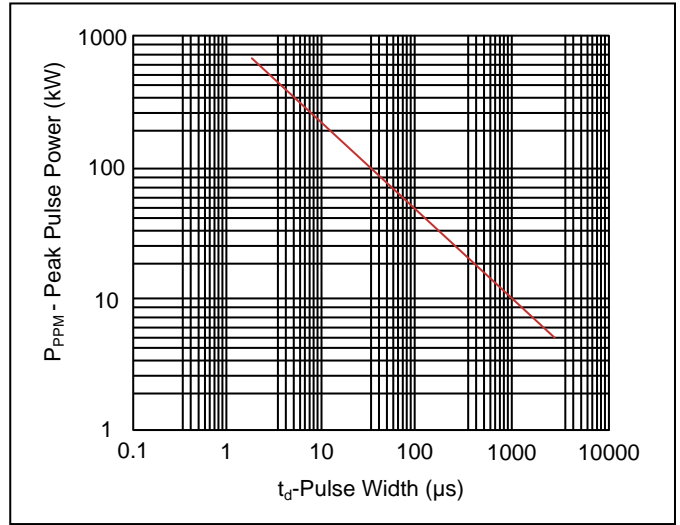

**Figure 3. Pulse Waveform**

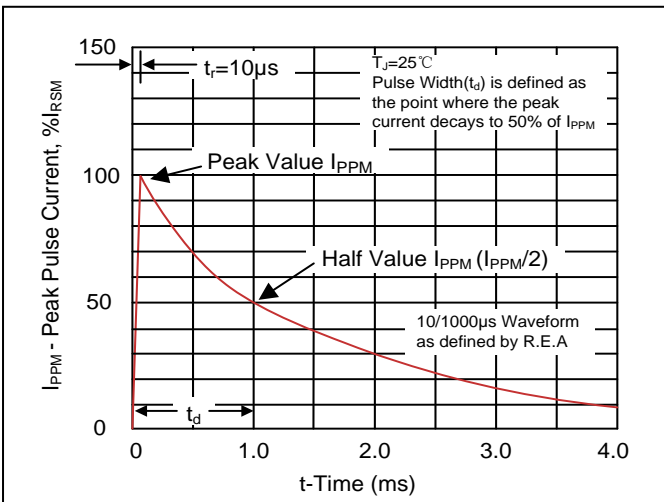

**Figure 4. Pulse Derating Curve**

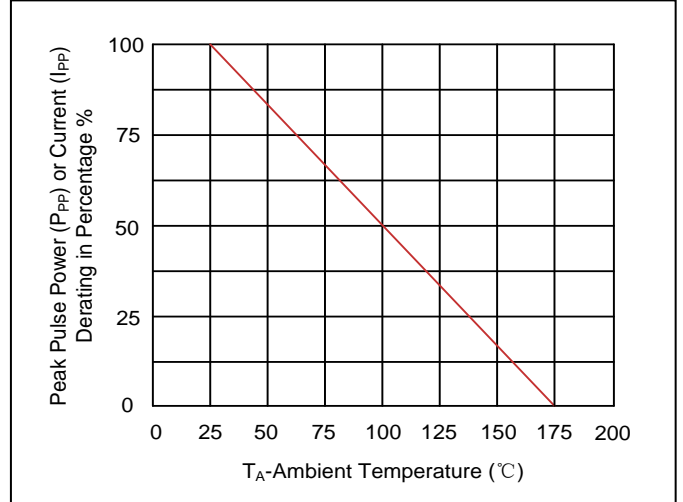

**Figure 5. Steady State Power Dissipation Derating Curve**

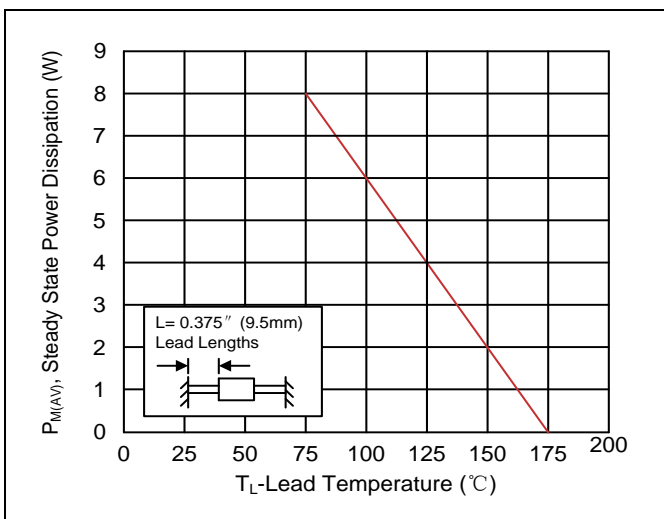

**Figure 6. Maximum Non-Repetitive Forward Surge Current Uni-Directional Only**

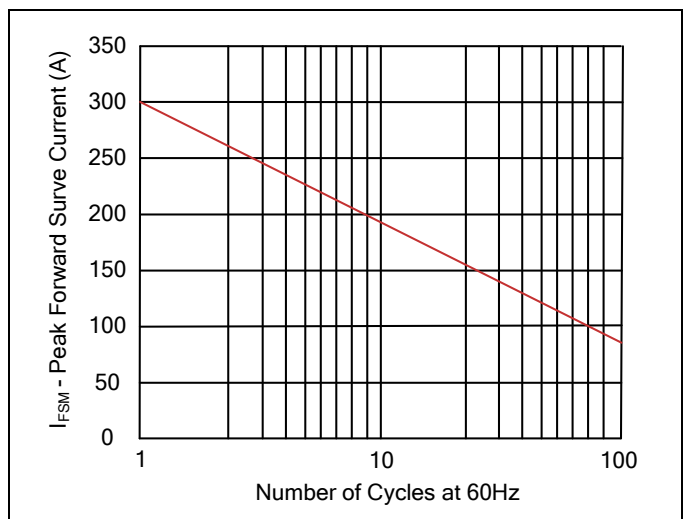

**Recommended Soldering Conditions**

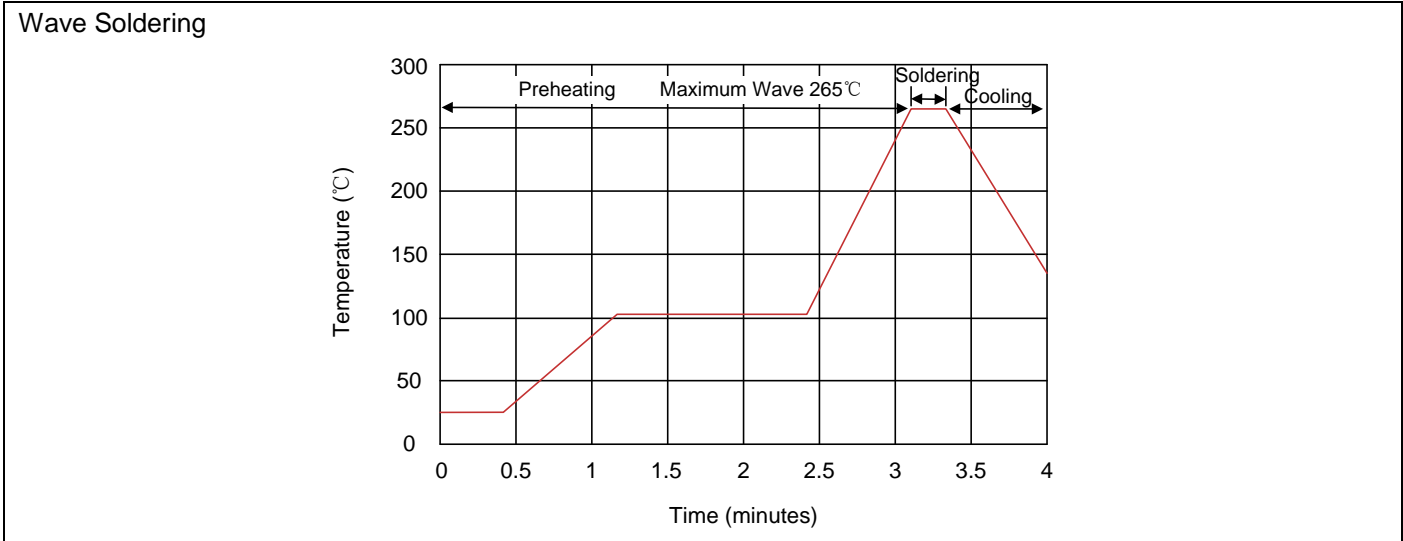

Recommended Conditions

Item	Conditions
Peak Temperature	265°C
Dipping Time	10 seconds
Soldering	1 time

**Marking Code**

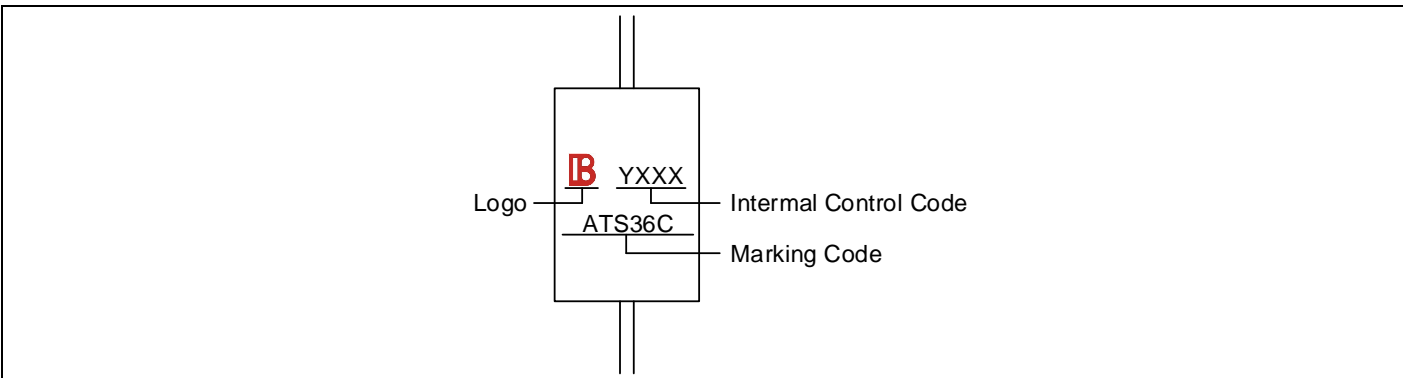

**Part Number Code**

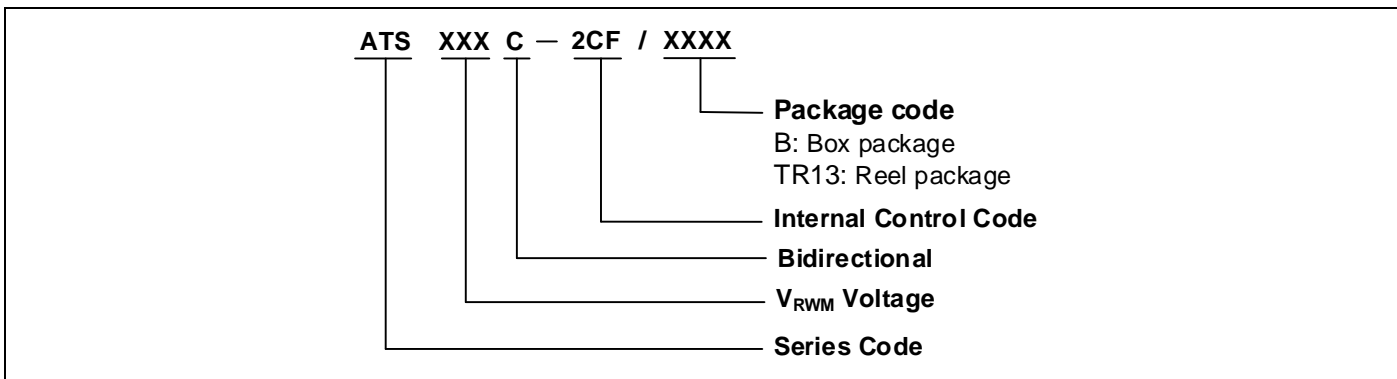

**Ordering Code for Different Package**

Box package: Add suffix "/B" at the end of the part number, such as ATSXXXC-2CF/B

Reel package: Add suffix "/TR13" at the end of the part number, such as ATSXXXC-2CF/TR13

**Packaging**

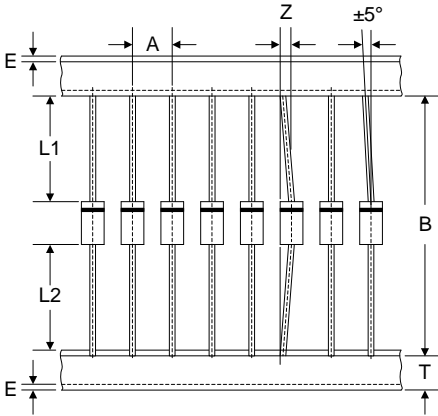
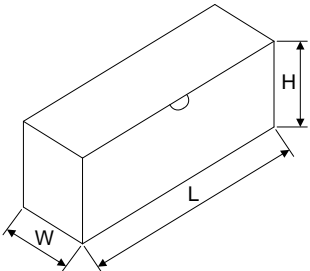
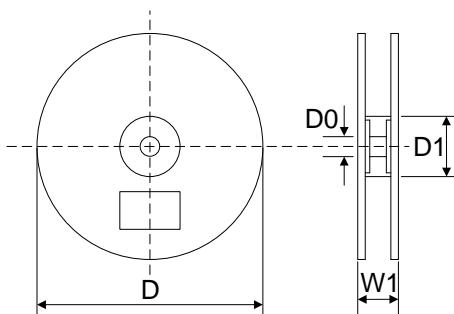
Tape	Symbol	Dimension (mm)	
	A	10.0±0.5	
	B	53.0±1.0	
	Z	1.2Max.	
	T	6.0±0.4	
	E	0.8Max.	
	L1-L2	1.0Max.	
		L	250.0±5.0
		W	75.0±5.0
		H	114.0±5.0
			Quantity: 300PCS
	D	330.0±3.0	
	D0	16.4±2.0	
	D1	86.0±2.0	
	W1	76.0±3.0	
			Quantity: 800PCS

## X-ON Electronics

Largest Supplier of Electrical and Electronic Components

*Click to view similar products for [ESD Suppressors / TVS Diodes](#) category:*

*Click to view products by [Yageo](#) manufacturer:*

Other Similar products are found below :

[D18V0L1B2LP-7B](#) [D5V0F4U5P5-7](#) [NTE4902](#) [P4KE27CA](#) [P6KE11CA](#) [P6KE8.2A](#) [SA60CA](#) [SA64CA](#) [SMBJ12CATR](#) [SMBJ33CATR](#)  
[SMBJ8.0A](#) [ESD101-B1-02ELS E6327](#) [ESD112-B1-02EL E6327](#) [ESD7451N2T5G](#) [19180-510](#) [CPDT-5V0USP-HF](#) [3.0SMCJ33CA-F](#)  
[3.0SMCJ36A-F](#) [HSPC16701B02TP](#) [JANTX1N6126A](#) [JANTX1N6173A](#) [JANTX1N6465](#) [D3V3Q1B2DLP3-7](#) [D55V0M1B2WS-7](#)  
[DRTR5V0U4SL-7](#) [SCM1293A-04SO](#) [ESD200-B1-CSP0201 E6327](#) [SM12-7](#) [SMQA1000T1G](#) [CEN955 W/DATA](#) [VESD12A1A-HD1-GS08](#)  
[CPDUR5V0R-HF](#) [CPDQC5V0-HF](#) [IP4042CX5/LF,135](#) [D1213A-01LP4-7B](#) [1SMB33CAT3G-XYZ](#) [ESD101-B1-02EL E6327](#) [AOZ8808DI-](#)  
[03](#) [5KP15A](#) [5KP48A](#) [5KP90A](#) [ESD3V3D7-TP](#) [ESDAVLC12-1BV2](#) [15KPA36A-LF](#) [NTE4900](#) [P4KE56CA](#) [P4KE68A](#) [P4KE91CATR](#)  
[P6KE120A](#) [P6KE13CA](#)