

# DATA SHEET

## SURFACE MOUNT MULTILAYER CERAMIC CAPACITORS

General purpose class II

X6S

4 V TO 50 V

100 pF to 47 $\mu$ F

RoHS compliant & Halogen free



Product specification – July 30, 2020 V.5



SCOPE

This specification describes X6S series chip capacitors with lead-free terminations.

APPLICATIONS

PCs, Hard disk, Game PCs  
 Power supplies  
 DVD players  
 Mobile phones  
 Data processing

FEATURES

Supplied in tape on reel  
 Nickel-barrier end termination  
 RoHS compliant  
 Halogen free compliant

ORDERING INFORMATION-GLOBAL PART NUMBER.

All part numbers are identified by the series, size, tolerance, TC material, packing style, voltage, process code, termination and capacitance value.

**YAGEO BRAND ordering code**

**GLOBAL PART NUMBER (PREFERRED)**

**CC** XXXX X X **X6S** X **BB** XXX  
 (1) (2) (3) (4) (5)

**(1) SIZE – INCH BASED (METRIC)**

0201 (0603)  
 0402 (1005)  
 0603 (1608)  
 0805 (2012)  
 1206 (3216)  
 1210 (3225)

**(2) TOLERANCE**

K = ±10%  
 M = ±20%

**(3) PACKING STYLE**

R = Paper/PE taping reel; Reel 7 inch  
 K = Blister taping reel; Reel 7 inch  
 P = Paper/PE taping reel; Reel 13 inch  
 F = Blister taping reel; Reel 13 inch  
 C = Bulk case

**(4) RATED VOLTAGE**

4 = 4 V  
 5 = 6.3 V  
 6 = 10 V  
 7 = 16 V  
 8 = 25 V  
 9 = 50 V

**(5) CAPACITANCE VALUE**

2 significant digits+number of zeros  
 The 3rd digit signifies the multiplying factor, and letter R is decimal point  
 Example: 103 = 10 × 10<sup>3</sup> = 10,000 pF = 10 nF

**CONSTRUCTION**

The capacitor consists of a rectangular block of ceramic dielectric in which a number of interleaved metal electrodes are contained. This structure gives rise to a high capacitance per unit volume.

The inner electrodes are connected to the two end terminations and finally covered with a layer of plated tin (NiSn). The terminations are lead-free. A cross section of the structure is shown in Fig.1.

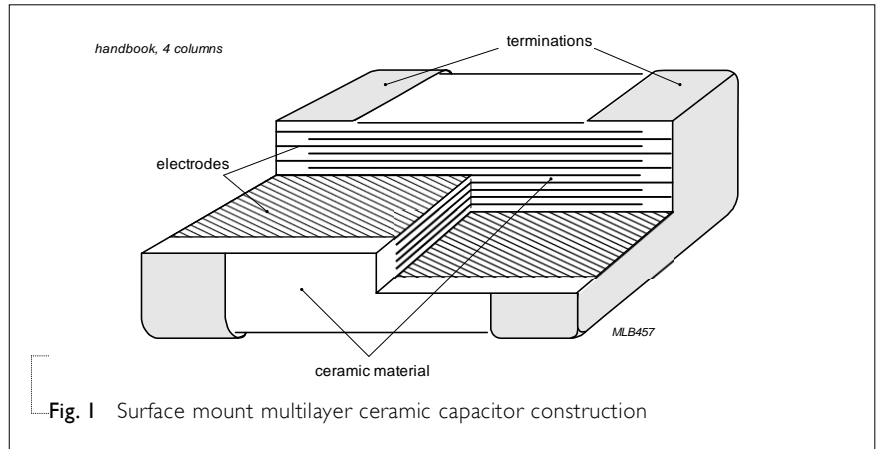

**DIMENSION**

Table I For outlines see fig. 2

TYPE	L <sub>1</sub> (mm)	W (mm)	T (MM)	L <sub>2</sub> / L <sub>3</sub> (mm)		L <sub>4</sub> (mm)
				min.	max.	min.
0201	0.6 ±0.03	0.3 ±0.03	0.3 ±0.03	0.10	0.20	0.20
	0.6±0.09	0.3 ±0.09	0.3±0.09			
0402	1.0 ±0.05	0.5 ±0.05	0.5 ±0.05	0.15	0.30	0.40
	1.0 ±0.15	0.5 ±0.15	0.5 ±0.15			
0603	1.6±0.10	0.8 ±0.10	0.8 ±0.10	0.20	0.60	0.40
	1.6 ±0.15	0.8 ±0.15	0.8 ±0.15			
0805	1.6 ±0.20	0.8 ±0.20	0.8 ±0.20	0.25	0.75	0.55
	2.0±0.20	1.25 ±0.20	1.25 ±0.20			
1206	3.2 ±0.30	1.6 ±0.20	1.6 ±0.20	0.25	0.75	1.40
1210	3.2 ±0.40	2.5 ±0.30	2.5 ±0.20	0.25	0.75	1.40
	3.2 ±0.40	2.5 ±0.30	2.5 ±0.30			

**OUTLINES**

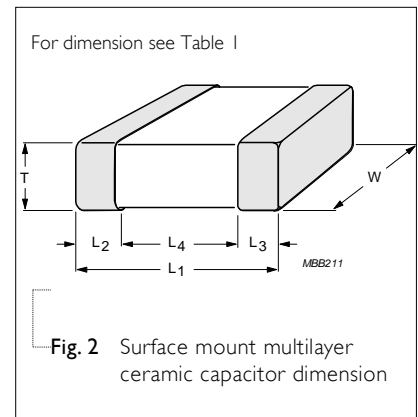

**CAPACITANCE RANGE & THICKNESS FOR X6S**

**Table 2** Sizes from 0201 to 0402

CAP.	0201				0402				0603					
	6.3V	10V	16V	25V	6.3V	10V	16V	25V	4V	6.3V	10V	16V	25V	50V
100 nF	0.3±0.03	0.3±0.03												
220 nF					0.5±0.05	0.5±0.05	0.5±0.05							
470 nF					0.5±0.05	0.5±0.05								
1 µF					0.5±0.05	0.5±0.05			0.8±0.1	0.8±0.1	0.8±0.1	0.8±0.1	0.8±0.1	
2.2 µF					0.5±0.20	0.5±0.20			0.8±0.1	0.8±0.1	0.8±0.1	0.8±0.2		
4.7 µF					0.5±0.15				0.8±0.2	0.8±0.2				
10 µF									0.8±0.2	0.8±0.2				
22 µF									0.8±0.2	0.8±0.2				
47 µF														

**Table 3** Sizes from 0805 to 1210

CAP.	0805					1206				1210			
	6.3V	10V	16V	25V	50V	6.3V	10V	16V	25V	6.3V	10V	16V	
100 nF													
220 nF													
470 nF													
1 µF													
2.2 µF	1.25±0.2	1.25±0.2	1.25±0.2	1.25±0.2	1.25±0.2								
4.7 µF	1.25±0.2	1.25±0.2	1.25±0.2	1.25±0.2									
10 µF	1.25±0.2	1.25±0.2	1.25±0.2			1.6±0.2	1.6±0.2	1.6±0.2	1.6±0.2				
22 µF	1.25±0.2					1.6±0.2	1.6±0.2	1.6±0.2					
47 µF										2.5±0.2	2.5±0.2		
100 µF													

**THICKNESS CLASSES AND PACKING QUANTITY**

Table 4

SIZE CODE	THICKNESS CLASSIFICATION	TAPE WIDTH QUANTITY PER REEL	Ø180 MM / 7 INCH		Ø330 MM / 13 INCH		QUANTITY PER BULK CASE
			Paper	Blister	Paper	Blister	
0201	0.3 ±0.03 mm	8 mm	15,000	---	50,000	---	---
0402	0.5 ±0.05 mm	8 mm	10,000	---	50,000	---	50,000
0603	0.8 ±0.1 mm	8 mm	4,000	---	15,000	---	15,000
0805	1.25 ±0.2 mm	8 mm	---	3,000	---	10,000	5,000
1206	1.6 ±0.2 mm	8 mm	---	2,000	---	8,000	---
1210	2.5±0.2/0.3 mm	8 mm	---	500	---	---	---

**ELECTRICAL CHARACTERISTICS**

**X6S DIELECTRIC CAPACITORS; NISN TERMINATIONS**

Unless otherwise specified, all tests and measurements shall be made under standard atmospheric conditions for testing as given in 5.3 of IEC 60068-1:

- Temperature: 15 °C to 35 °C
- Relative humidity: 25% to 75%
- Air pressure: 86 kPa to 106 kPa

Before the measurements are made, the capacitor shall be stored at the measuring temperature for a time sufficient to allow the entire capacitor to reach this temperature.

The period as prescribed for recovery at the end of a test is normally sufficient for this purpose.

Table 5

DESCRIPTION	VALUE
Capacitance range	100 nF to 100 µF
Capacitance tolerance	±10% and ±20%
Dissipation factor (D.F.)	≤10%
Insulation resistance after 1 minute at $U_r$ (DC)	$R_{ins} \times C_r \geq 100 / 50 \Omega.F *$
Maximum capacitance change as a function of temperature (temperature characteristic/coefficient):	±22%
Operating temperature range:	-55 °C to +105 °C

**Note:**

$R_{ins} \times C_r \geq 100 \Omega.F$

0201: 100nF to 470nF

0402: 470nF, 1µF/ 6.3V to 10V

0603: 1µF, 2.2µF/ 6.3V to 16V, 4.7µF/ 6.3V to 16V

0805: 2.2µF, 4.7µF to 10µF/ 6.3V to 16V

1206: 10µF/ 6.3V to 16V, 22µF/ 6.3V to 10V

$R_{ins} \times C_r \geq 50 \Omega.F$

0201: 1µF

0402: 220nF, 1µF/ 16V to 25V, 2.2µF, 4.7µF to 10µF/ 6.3V

0603: 2.2µF/ 25V, 4.7µF/ 25V, 10µF to 22µF

0805: 4.7µF/ 50V, 10µF/ 25V, 22µF to 47µF

1206: 10µF/ 25V, 22µF/ 16V, 47µF to 100µF

1210: 47µF to 100µF

## SOLDERING RECOMMENDATION

Table 6

SOLDERING METHOD	SIZE ≤ 0402	0603	0805	1206	≥ 1210
Reflow	Reflow only	≥ 1.0 μF	≥ 2.2 μF	≥ 4.7 μF	Reflow only
Reflow/Wave	---	< 1.0 μF	< 2.2 μF	< 4.7 μF	---

## TESTS AND REQUIREMENTS

Table 7 Test procedures and requirements

TEST	TEST METHOD	PROCEDURE	REQUIREMENTS
Mounting	IEC 60384-21/22 4.3	The capacitors may be mounted on printed-circuit boards or ceramic substrates	No visible damage
Visual Inspection and Dimension Check	4.4	Any applicable method using × 10 magnification	In accordance with specification
Capacitance <sup>(1)</sup>	4.5.1	Class 2: At 20 °C, 24 hrs after annealing Cap ≤ 1 μF, f = 1 KHz, measuring at voltage 1 Vrms at 20 °C Cap > 1 μF, f = 1 KHz for C ≤ 10 μF, rated voltage > 6.3 V, measuring at voltage 1 Vrms at 20 °C f = 1 KHz, for C ≤ 10 μF, rated voltage ≤ 6.3 V, measuring at voltage 0.5 to 1 Vrms at 20 °C f = 120 Hz for C > 10 μF, measuring at voltage 0.5 Vrms at 20 °C	Within specified tolerance
Dissipation Factor (D.F.) <sup>(1)</sup>	4.5.2	Class 2: At 20 °C, 24 hrs after annealing Cap ≤ 1 μF, f = 1 KHz, measuring at voltage 1 Vrms at 20 °C Cap > 1 μF, f = 1 KHz for C ≤ 10 μF, rated voltage > 6.3 V, measuring at voltage 1 Vrms at 20 °C f = 1 KHz, for C ≤ 10 μF, rated voltage ≤ 6.3 V, measuring at voltage 0.5 Vrms at 20 °C f = 120 Hz for C > 10 μF, measuring at voltage 0.5 Vrms at 20 °C	In accordance with specification
Insulation Resistance	4.5.3	At U <sub>r</sub> (DC) for 1 minute	In accordance with specification

### NOTE

1. The figure indicates typical inspection. Please refer to individual specifications.

TEST	TEST METHOD	PROCEDURE	REQUIREMENTS												
Temperature Characteristic	4.	<p>Capacitance shall be measured by the steps shown in the following table.</p> <p>The capacitance change should be measured after 5 min at each specified temperature stage.</p> <table border="1" style="margin-left: 20px; border-collapse: collapse;"> <thead> <tr> <th>Step</th> <th>Temperature(°C)</th> </tr> </thead> <tbody> <tr> <td>a</td> <td>25±2</td> </tr> <tr> <td>b</td> <td>Lower temperature±3°C</td> </tr> <tr> <td>c</td> <td>25±2</td> </tr> <tr> <td>d</td> <td>Upper Temperature±2°C</td> </tr> <tr> <td>e</td> <td>25±2</td> </tr> </tbody> </table> <p>(1) Class I</p> <p>Temperature Coefficient shall be calculated from the formula as below</p> $\text{Temp. Coefficient} = \frac{C2 - C1}{C1 \times \Delta T} \times 10^6 \text{ [ppm/°C]}$ <p>C1: Capacitance at step c                      C2: Capacitance at 125°C                      ΔT: 100°C(=125°C-25°C)</p> <p>(2) Class II</p> <p>Capacitance Change shall be calculated from the formula as below</p> $\Delta C = \frac{C2 - C1}{C1} \times 100\%$ <p>C1: Capacitance at step c                      C2: Capacitance at step b or d</p>	Step	Temperature(°C)	a	25±2	b	Lower temperature±3°C	c	25±2	d	Upper Temperature±2°C	e	25±2	<p>Class1: Δ C/C: ±30ppm</p> <p>Class2: X6S: Δ C/C: ±22%</p>
Step	Temperature(°C)														
a	25±2														
b	Lower temperature±3°C														
c	25±2														
d	Upper Temperature±2°C														
e	25±2														
Adhesion	4.7	A force applied for 10 seconds to the line joining the terminations and in a plane parallel to the substrate	<p>Force</p> <p>size ≥ 0603: 5N                      size = 0402: 2.5N                      size = 0201: 1N</p>												
Bending Strength	IEC 60384-21/22 4.8	<p>Mounting in accordance with IEC 60384-22 paragraph 4.3</p> <hr/> <p>Conditions: bending 1 mm at a rate of 1 mm/s, radius jig 5 mm</p>	<p>No visible damage</p> <hr/> <p>ΔC/C</p> <p>Class2: X6S: ±10%</p>												

TEST	TEST METHOD	PROCEDURE	REQUIREMENTS
Resistance to Soldering Heat	4.9	Precondition: 150 +0/-10 °C for 1 hour, then keep for 24 ±1 hours at room temperature Preheating: for size ≤ 1206: 120 °C to 150 °C for 1 minute Preheating: for size >1206: 100 °C to 120 °C for 1 minute and 170 °C to 200 °C for 1 minute Solder bath temperature: 260 ±5 °C Dipping time: 10 ±0.5 seconds Recovery time: 24 ±2 hours	Dissolution of the end face plating shall not exceed 25% of the length of the edge concerned <hr/> ΔC/C Class2: X6S: ±10% <hr/> D.F. within initial specified value R <sub>ins</sub> within initial specified value
Solderability	4.10	Preheated the temperature of 80 °C to 140 °C and maintained for 30 seconds to 60 seconds.  1. Temperature: 235±5°C / Dipping time: 2 ±0.5 s 2. Temperature: 245±5°C / Dipping time: 3 ±0.5 s (lead free) Depth of immersion: 10mm	The solder should cover over 95% of the critical area of each termination
Rapid Change of Temperature	IEC 60384-21/22 4.11	Preconditioning: 150 +0/-10 °C for 1 hour, then keep for 24 ±1 hours at room temperature  5 cycles with following detail: 30 minutes at lower category temperature 30 minutes at upper category temperature  Recovery time 24 ±2 hours	No visual damage <hr/> ΔC/C Class2: X6S: ±15% <hr/> D.F. meet initial specified value R <sub>ins</sub> meet initial specified value



TEST	TEST METHOD	PROCEDURE	REQUIREMENTS
Damp Heat with U <sub>r</sub> Load	4.13	<ol style="list-style-type: none"> <li>Preconditioning, class 2 only: 150 +0/-10 °C /1 hour, then keep for 24 ±1 hour at room temp</li> <li>Initial measure: Spec: refer to initial spec C, D, IR</li> <li>Damp heat test: 500 ±12 hours at 40 ±2 °C; 90 to 95% R.H. 1.0 U<sub>r</sub> applied</li> <li>Recovery: Class 2: 24 ±2 hours</li> <li>Final measure: C, D, IR P.S. If the capacitance value is less than the minimum value permitted, then after the other measurements have been made the capacitor shall be preconditioned according to "IEC 60384 4.1" and then the requirements shall be met.</li> </ol>	<p>No visual damage after recovery</p> <hr/> <p>ΔC/C Class2: ±20% D.F. Class2: 2 × initial value max R<sub>ins</sub> Class2: R<sub>ins</sub> × Cr ≥ 5s whichever is less</p>
Endurance	IEC 60384-21/22 4.14	<ol style="list-style-type: none"> <li>Preconditioning, class 2 only: 150 +0/-10 °C /1 hour, then keep for 24 ±1 hour at room temp</li> <li>Initial measure: Spec: refer to initial spec C, D, IR</li> <li>Endurance test: Temperature: X6S: 105 °C Specified stress voltage applied for 1,000 hours: Applied 1.5 × U<sub>r</sub>. Applied 1 U<sub>r</sub>: 0201: 1uF 0402: 4.7uF, 10uF 0603: 10uF, 22uF 0805: 10uF/ 25V, 22uF/ 16V Recovery time: 24 ±2 hours</li> <li>Final measure: C, D, IR P.S. If the capacitance value is less than the minimum value permitted, then after the other measurements have been made the capacitor shall be preconditioned according to "IEC 60384 4.1" and then the requirements shall be met.</li> </ol>	<p>No visual damage</p> <hr/> <p>ΔC/C Class 2: ±20% D.F. Class 2: 2 × initial value max R<sub>ins</sub> Class 2: R<sub>ins</sub> × Cr ≥ 10s</p>
Voltage Proof	IEC 60384-1 4.6	<p>Specified stress voltage applied for 1~5 seconds U<sub>r</sub> ≤ 100 V: series applied 2.5 U<sub>r</sub> Charge/Discharge current is less than 50 mA</p>	<p>No breakdown or flashover</p>

REVISION HISTORY

REVISION	DATE	CHANGE NOTIFICATION	DESCRIPTION
Version 5	Jun. 2, 2020	-	- Product range updated
Version 4	Aug 7, 2017	-	- 0402 Dimension update
Version 3	Jul 19, 2017	-	- Product range updated
Version 2	Feb. 20, 2017	-	- Dimension & capacitance update
Version 1	Sep. 16, 2015	-	- Dimension & capacitance update
Version 0	Nov. 18, 2014	-	- New datasheet for general purpose High Cap X6S

## X-ON Electronics

Largest Supplier of Electrical and Electronic Components

*Click to view similar products for [Multilayer Ceramic Capacitors MLCC - SMD/SMT category](#):*

*Click to view products by [Yageo manufacturer](#):*

Other Similar products are found below :

[D55342E07B523DR-T/R](#) [NCA1206X7R103K50TRPF](#) [NCA1206X7R104K16TRPF](#) [NIN-FB391JTRF](#) [NIN-FC2R7JTRF](#)  
[NMC0402NPO220J50TRPF](#) [NMC0402X5R105K6.3TRPF](#) [NMC0402X5R224K6.3TRPF](#) [NMC0402X7R103J25TRPF](#)  
[NMC0402X7R153K16TRPF](#) [NMC0603NPO330G50TRPF](#) [NMC0603NPO331F50TRPF](#) [NMC0603X5R475M6.3TRPF](#)  
[NMC0805NPO220J100TRPF](#) [NMC0805NPO270J50TRPF](#) [NMC0805NPO681F50TRPF](#) [NMC0805NPO820J50TRPF](#)  
[NMC1206X7R102K50TRPF](#) [NMC1210Y5V105Z50TRPLPF](#) [NMC-H0805X7R472K250TRPF](#) [NMC-L0402NPO7R0C50TRPF](#) [NMC-](#)  
[L0603NPO2R2B50TRPF](#) [NMC-Q0402NPO8R2D200TRPF](#) [C1206C101J1GAC](#) [C1608C0G2A221J](#) [C1608X7R1E334K](#) [C2012C0G2A472J](#)  
[2220J2K00562KXT](#) [KHC201E225M76N0T00](#) [1812J2K00332KXT](#) [CCR06CG153FSV](#) [CDR14BP471CJUR](#) [CDR31BX103AKWR](#)  
[CDR33BX683AKUS](#) [CGA2B2C0G1H010C](#) [CGA2B2C0G1H040C](#) [CGA2B2C0G1H050C](#) [CGA2B2C0G1H060D](#) [CGA2B2C0G1H070D](#)  
[CGA2B2C0G1H120J](#) [CGA2B2C0G1H151J](#) [CGA2B2C0G1H1R5C](#) [CGA2B2C0G1H2R2C](#) [CGA2B2C0G1H390J](#) [CGA2B2C0G1H391J](#)  
[CGA2B2C0G1H3R3C](#) [CGA2B2C0G1H680J](#) [CGA2B2C0G1H6R8D](#) [CGA2B2C0G1H820J](#) [CGA2B2X8R1H152K](#)