

CLH Series

Lead-free / For High Frequency Applications

Multilayer Chip Inductors High Frequency

APPLICATIONS

RF Resonance and Impedance Matching Circuit

RF and Wireless Communication

Information Technology Equipments, Computers, Telecommunications, Radar Detectors, Automotive Electronics, Cellular Phones, Pagers, PDAs, Keyless Remote Systems.

Use in L-C Filter Configurations

OUTLINE

Yageo high frequency multilayer ceramic chip inductor is formed without wound wire.

Monolithic laminated structure.

FEATURES

Meet SONY SS-00259's criteria for lead-free product.

Excellent Q Factor and SRF Characteristic

Cost Effective

Small size of 1005/1608 is suitable for small portable equipment.

Supports Operating Frequency up to 6GHz with Nominal Inductance Values from 1.0nH To 330nH

SHAPES AND DIMENSIONS

Dimensions : mm

CLH1608-W series
CLH2012-S series

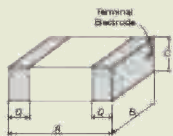

CLH1005-S series
CLH1608-S series

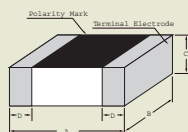

CLH1005-H series
CLH1608-H series

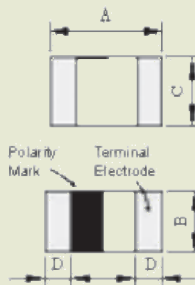

TYPE	A	B	C	D
CLH1005	1.00 ± 0.10	0.50 ± 0.10	0.50 ± 0.10	0.25 ± 0.10
CLH1608	1.60 ± 0.15	0.80 ± 0.15	0.80 ± 0.15	0.30 ± 0.20
CLH2012	2.00 ± 0.20	1.25 ± 0.20	0.90 ± 0.20	0.50 ± 0.30

RECOMMENDED PATTERN

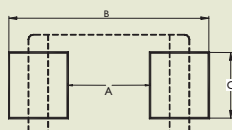

A	B	C
0.4	1.2~1.4	0.4
0.8	2.4~3.4	0.6
1.2	3.0~4.0	1.0



PRODUCT IDENTIFICATION

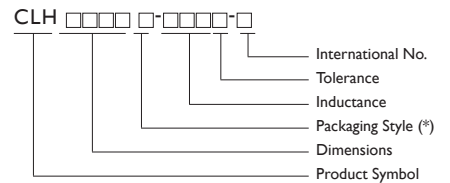

* B: Bulk ; T: Tape and Reel

CLH1005-H



CLH1005-S

CLH1608-H



CLH1608-W
CLH2012-S

CLH1608-S



ELECTRICAL CHARACTERISTICS CLH1005T (0402) SERIES: LEAD-FREE & ROHS COMPLIANCE

PART NO.	INDUCTANCE at 100MHz (nH)	TOLERANCE	Q Min. at 100MHz	Q TYPICAL		SRF (MHz) Min.	DC RESISTANCE (Ω) Max.	RATED CURRENT (mA) Max.
				at 100MHz	at 800MHz			
CLH1005T-1N0 □ -N	1.0	S	8	9	28	10,000	0.12	300
CLH1005T-1N2 □ -N	1.2	S	8	9	28	10,000	0.12	300
CLH1005T-1N5 □ -N	1.5	S	8	10	28	9,000	0.13	300
CLH1005T-1N8 □ -N	1.8	S	8	10	28	8,700	0.14	300
CLH1005T-2N2 □ -N	2.2	S	8	10	29	8,100	0.16	300
CLH1005T-2N7 □ -N	2.7	S	8	11	30	7,700	0.17	300
CLH1005T-3N3 □ -N	3.3	S, K	8	11	30	6,300	0.19	300
CLH1005T-3N9 □ -N	3.9	S, K	8	11	31	6,100	0.22	300
CLH1005T-4N7 □ -N	4.7	S, K	8	11	31	5,400	0.24	300
CLH1005T-5N6 □ -N	5.6	S, K	8	11	31	5,100	0.27	300
CLH1005T-6N8 □ -N	6.8	J, K	8	11	33	4,550	0.32	250
CLH1005T-8N2 □ -N	8.2	J, K	8	12	32	4,100	0.40	250
CLH1005T-10N □ -N	10	J, K	8	12	32	3,900	0.45	250
CLH1005T-12N □ -N	12	J, K	8	12	31	3,000	0.50	250
CLH1005T-15N □ -N	15	J, K	8	12	30	2,600	0.60	250
CLH1005T-18N □ -N	18	J, K	8	12	29	2,350	0.65	200
CLH1005T-22N □ -N	22	J, K	8	12	28	2,000	0.80	200
CLH1005T-27N □ -N	27	J, K	8	12	27	1,900	0.90	200
CLH1005T-33N □ -N	33	J, K	8	10	25	1,700	1.00	200
CLH1005T-39N □ -N	39	J, K	8	10	25	1,600	1.20	150
CLH1005T-47N □ -N	47	J, K	8	9	22	1300	1.30	150
CLH1005T-56N □ -N	56	J, K	8	10	21	1250	2.00	150
CLH1005T-68N □ -N	68	J, K	8	10	15	1000	2.20	100
CLH1005T-82N □ -N	82	J, K	8	9	13	900	2.50	100
CLH1005T-R10 □ -N	100	J, K	8	9	10	850	2.50	100

Note : Tolerance : □-S = $\pm 0.3\text{nH}$ J = $\pm 5\%$ K = $\pm 10\%$

Test Conditions : L/Q- Agilent E4991A

Fixture : Agilent 16197A

SRF - HP8753D

RDC - HP4338B / CH502BC



ELECTRICAL CHARACTERISTICS

PART NO.	INDUCTANCE at 100MHz (nH)	TOLERANCE	Q Min. at 100MHz	Q TYPICAL		SRF (MHz) Typical	DC RESISTANCE (Ω) Max.	IDC (mA) MAX.
				at 100MHz	at 800MHz			
CLH1005T-1N0 □ -H	1.0	S	8	9	28	10000	0.12	300
CLH1005T-1N2 □ -H	1.2	S	8	9	28	10000	0.12	300
CLH1005T-1N5 □ -H	1.5	S	8	10	28	9000	0.13	300
CLH1005T-1N8 □ -H	1.8	S	8	10	28	8700	0.14	300
CLH1005T-2N2 □ -H	2.2	S	8	10	29	8100	0.16	300
CLH1005T-2N7 □ -H	2.7	S	8	11	30	7700	0.17	300
CLH1005T-3N3 □ -H	3.3	S, K	8	11	30	6300	0.19	300
CLH1005T-3N9 □ -H	3.9	S, K	8	11	31	6100	0.22	300
CLH1005T-4N7 □ -H	4.7	S, K	8	11	31	5400	0.24	300
CLH1005T-5N6 □ -H	5.6	S, K	8	11	31	5100	0.27	300
CLH1005T-6N8 □ -H	6.8	J, K	8	11	33	4550	0.32	250
CLH1005T-8N2 □ -H	8.2	J, K	8	12	32	4100	0.40	250
CLH1005T-10N □ -H	10	J, K	8	12	32	3900	0.45	250
CLH1005T-12N □ -H	12	J, K	8	12	31	3000	0.50	250
CLH1005T-15N □ -H	15	J, K	8	12	30	2600	0.60	250
CLH1005T-18N □ -H	18	J, K	8	12	29	2350	0.65	200
CLH1005T-22N □ -H	22	J, K	8	12	28	2000	0.80	200
CLH1005T-27N □ -H	27	J, K	8	12	27	1900	0.90	200
CLH1005T-33N □ -H	33	J, K	8	10	25	1700	1.00	200
CLH1005T-39N □ -H	39	J, K	8	10	25	1600	1.20	150
CLH1005T-47N □ -H	47	J, K	8	10	22	1300	1.30	150
CLH1005T-56N □ -H	56	J, K	8	10	21	1250	2.00	150
CLH1005T-68N □ -H	68	J, K	8	10	19	1000	2.20	100
CLH1005T-82N □ -H	82	J, K	8	10	16	900	2.50	100
CLH1005T-R10 □ -H	100	J, K	8	10	10	850	2.50	100

Note : Tolerance : □ -S = ±0.3nH J = ±5% K = ±10%

Test Conditions : L/Q- HP4291A+HP16192A

SRF - HP4291A+HP16192A OR HP8753D

RDC - HP4338B / CH502BC

IDC - HP4291A / HP6632A



ELECTRICAL CHARACTERISTICS CLHI608T (0603) SERIES

PART NO.	INDUCTANCE at 100MHz (nH)	TOLERANCE	Q Min. at 100MHz	Q TYPICAL		SRF (MHz) Min.	DC RESISTANCE (Ω) Max.	RATED CURRENT (mA) Max.
				at 100MHz	at 800MHz			
				CLHI608T-1N0 □ -N	1.0			
CLHI608T-1N2 □ -N	1.2	S	8	13	60	10,000	0.10	500
CLHI608T-1N5 □ -N	1.5	S	8	13	57	8,000	0.10	500
CLHI608T-1N8 □ -N	1.8	S	8	13	51	8,000	0.10	500
CLHI608T-2N2 □ -N	2.2	S	8	13	46	7,200	0.10	500
CLHI608T-2N7 □ -N	2.7	S	10	13	46	6,200	0.10	500
CLHI608T-3N3 □ -N	3.3	S, K	10	13	47	5,200	0.12	500
CLHI608T-3N9 □ -N	3.9	S, K	10	13	47	5,000	0.14	500
CLHI608T-4N7 □ -N	4.7	S, K	10	13	41	4,750	0.16	500
CLHI608T-5N6 □ -N	5.6	S, K	10	13	41	4,100	0.18	500
CLHI608T-6N8 □ -N	6.8	J, K	10	13	44	3750	0.22	500
CLHI608T-8N2 □ -N	8.2	J, K	10	13	44	3300	0.24	500
CLHI608T-10N □ -N	10	J, K	12	13	45	3,000	0.26	300
CLHI608T-12N □ -N	12	J, K	12	15	46	2,600	0.28	300
CLHI608T-15N □ -N	15	J, K	12	15	48	2,500	0.32	300
CLHI608T-18N □ -N	18	J, K	12	15	48	2,400	0.35	300
CLHI608T-22N □ -N	22	J, K	12	17	45	2,000	0.40	300
CLHI608T-27N □ -N	27	J, K	12	17	43	1,900	0.45	300
CLHI608T-33N □ -N	33	J, K	12	18	39	1,600	0.55	300
CLHI608T-39N □ -N	39	J, K	12	18	37 ***	1400	0.60	300
CLHI608T-47N □ -N	47	J, K	12	18	35 ***	1,300	0.70	300
CLHI608T-56N □ -N	56	J, K	12	18	32 ***	1100	0.75	300
CLHI608T-62N □ -N	62	J, K	12	18	34 ***	1050	0.85	300
CLHI608T-68N □ -N	68	J, K	12	18	34 ***	1050	0.85	300
CLHI608T-82N □ -N	82	J, K	12	18	32 ***	900	1.00	300
CLHI608T-R10 □ -N	100	J, K	12	18	20 ***	770	1.20	300
CLHI608T-R12 □ -N	120 *	J, K	8 *	14 *	20 **	850	2.3	250
CLHI608T-R15 □ -N	150 *	J, K	8 *	15 *	16 **	550	2.4	250
CLHI608T-R18 □ -N	180 *	J, K	8 *	15 *	16 **	520	2.7	250

Note : * at 50MHz ** at 300MHz *** at 500MHz

Tolerance : □ S = $\pm 0.3nH$ J = $\pm 5\%$ K = $\pm 10\%$

Test L/Q : HP4291A+HP16192A

Conditions : SRF: HP4291A+HP16192A

RDC: HP4338B / CH502BC

IDC: HP4291A + HP6632A



ELECTRICAL CHARACTERISTICS

PART NO.	INDUCTANCE at 100MHz (nH)	TOLERANCE	Q Min.		Q TYPICAL(MHz)					SRF (MHz) TYPICAL	DC RESISTANCE (Ω) Max.	IDC (mA) MAX	
			AT 50MHz	100MHz	AT 50	100	300	500	800				
CLH1608T-1N0S-H	1.0	S		8		12				43	10000	0.10	500
CLH1608T-1N2S-H	1.2	S		8		13				44	10000	0.10	500
CLH1608T-1N5S-H	1.5	S		8		13				45	8000	0.10	500
CLH1608T-1N8S-H	1.8	S		8		13				46	8000	0.10	500
CLH1608T-2N2S-H	2.2	S		8		13				46	7200	0.10	500
CLH1608T-2N7S-H	2.7	S		10		13				46	6200	0.10	500
CLH1608T-3N3 □ -H	3.3	S, K		10		13				47	5200	0.12	500
CLH1608T-3N9 □ -H	3.9	S, K		10		13				47	5000	0.14	500
CLH1608T-4N7 □ -H	4.7	S, K		10		13				41	4750	0.16	500
CLH1608T-5N6 □ -H	5.6	S, K		10		13				41	4100	0.18	500
CLH1608T-6N8 □ -H	6.8	J, K		10		13				44	3750	0.22	500
CLH1608T-8N2 □ -H	8.2	J, K		10		13				44	3300	0.24	500
CLH1608T-10N □ -H	10	J, K		12		13				45	3000	0.26	300
CLH1608T-12N □ -H	12	J, K		12		15				46	2600	0.28	300
CLH1608T-15N □ -H	15	J, K		12		15				48	2500	0.32	300
CLH1608T-18N □ -H	18	J, K		12		15				48	2400	0.35	300
CLH1608T-22N □ -H	22	J, K		12		17				45	2000	0.40	300
CLH1608T-27N □ -H	27	J, K		12		17				43	1900	0.45	300
CLH1608T-33N □ -H	33	J, K		12		18				39	1600	0.55	300
CLH1608T-39N □ -H	39	J, K		12		18		37			1400	0.60	300
CLH1608T-47N □ -H	47	J, K		12		18		35			1300	0.70	300
CLH1608T-56N □ -H	56	J, K		12		18		32			1100	0.75	300
CLH1608T-62N □ -H	62	J, K		12		18		32			1050	0.85	300
CLH1608T-68N □ -H	68	J, K		12		18		32			1050	0.85	300
CLH1608T-82N □ -H	82	J, K		12		18		30			900	1.00	300
CLH1608T-R10 □ -H	100	J, K		12		18		20			770	1.20	300
CLH1608T-R12 □ -H	*120	J, K	8			14		20			850	2.30	250
CLH1608T-R15 □ -H	*150	J, K	8			15		16			550	2.40	250
CLH1608T-R18 □ -H	*180	J, K	8			15		16			520	2.70	250

Note : * at 50MHz

Tolerance : □ - S = ±0.3nH J = ±5% K = ±10%

Test L/Q - HP4291A+HPI6192A

Conditions : SRF - HP4291A+HPI6192A

 RDC - Digital Multimeter SC-7401

 IDC - HP4291A+HP6632A



ELECTRICAL CHARACTERISTICS

PART NO.	INDUCTANCE at 100MHz (nH)	TOLERANCE	Q Min.		Q TYPICAL(MHz)					SRF (MHZ) TYPICAL	DC RESISTANCE (Ω) Max.	IDC (mA) MAX
			AT 50MHz	100MHz	AT 50	100	300	500	800			
CLHI608T-1N0S-W	1.0	S		8						10000	0.10	500
CLHI608T-1N2S-W	1.2	S		8						10000	0.10	500
CLHI608T-1N5S-W	1.5	S		8						8000	0.10	500
CLHI608T-1N8S-W	1.8	S		8						8000	0.10	500
CLHI608T-2N2S-W	2.2	S		8						7200	0.10	500
CLHI608T-2N7S-W	2.7	S		10						6200	0.10	500
CLHI608T-3N3 □ -W	3.3	S, K		10						5200	0.12	500
CLHI608T-3N9 □ -W	3.9	S, K		10						5000	0.14	500
CLHI608T-4N7 □ -W	4.7	S, K		10						4750	0.16	500
CLHI608T-5N6 □ -W	5.6	S, K		10						4100	0.18	500
CLHI608T-6N8 □ -W	6.8	J, K		10						3750	0.22	500
CLHI608T-8N2 □ -W	8.2	J, K		10						3300	0.24	500
CLHI608T-10N □ -W	10	J, K		12						3000	0.26	300
CLHI608T-12N □ -W	12	J, K		12						2600	0.28	300
CLHI608T-15N □ -W	15	J, K		12						2500	0.32	300
CLHI608T-18N □ -W	18	J, K		12						2400	0.35	300
CLHI608T-22N □ -W	22	J, K		12						2000	0.40	300
CLHI608T-27N □ -W	27	J, K		12						1900	0.45	300
CLHI608T-33N □ -W	33	J, K		12						1600	0.55	300
CLHI608T-39N □ -W	39	J, K		12				37		1400	0.60	300
CLHI608T-47N □ -W	47	J, K		12				35		1300	0.70	300
CLHI608T-56N □ -W	56	J, K		12				32		1100	0.75	300
CLHI608T-62N □ -W	62	J, K		12				32		1050	0.85	300
CLHI608T-68N □ -W	68	J, K		12				32		1050	0.85	300
CLHI608T-82N □ -W	82	J, K		12				30		900	1.00	300
CLHI608T-R10 □ -W	100	J, K		12				20		770	1.20	300
CLHI608T-R12 □ -W	*120	J, K	8			14		20		850	2.30	250
CLHI608T-R15 □ -W	*150	J, K	8			15		16		550	2.40	250
CLHI608T-R18 □ -W	*180	J, K	8			15		16		520	2.70	250

Note : * at 50MHz

Tolerance : □ - S = ±0.3nH J = ±5% K = ±10%

Test L/Q - HP4291A+HP16192A

Conditions : SRF - HP4291A+HP16192A

 RDC - Digital Multimeter SC-7401

 IDC - HP4291A+HP6632A



ELECTRICAL CHARACTERISTICS CLH2012T (0805) SERIES : LEAD FREE & ROHS COMPLIANCE

PART NO.	INDUCTANCE at 100MHz (nH)	TOLERANCE	Q Min.	Q TYPICAL			SRF (MHz)Typical	DC RESISTANCE (Ω) Max.	IDC (mA) Max.
				at 50MHz	at 100MHz	at 800MHz			
CLH2012T-1N0□-N	1.0	S		10	13	40	> 6000	0.10	300
CLH2012T-1N2□-N	1.2	S		10	13	40	> 6000	1.10	300
CLH2012T-1N5□-N	1.5	S		10	13	40	> 6000	0.10	300
CLH2012T-1N8□-N	1.8	S		10	13	45	> 6000	0.10	300
CLH2012T-2N2□-N	2.2	S		10	13	48	> 6000	0.10	300
CLH2012T-2N7□-N	2.7	S		12	13	48	> 6000	0.10	300
CLH2012T-3N3□-N	3.3	S, K		12	15	56	> 6000	0.13	300
CLH2012T-3N9□-N	3.9	S, K		12	15	54	5400	0.15	300
CLH2012T-4N7□-N	4.7	S, K		12	15	50	4500	0.20	300
CLH2012T-5N6□-N	5.6	S, K		12	15	53	4000	0.23	300
CLH2012T-6N8□-N	6.8	J, K		15	15	51	3650	0.25	300
CLH2012T-8N2□-N	8.2	J, K		15	15	53	3000	0.28	300
CLH2012T-10N□-N	10	J, K		15	16	45	2500	0.30	300
CLH2012T-12N□-N	12	J, K		15	16	48	2450	0.35	300
CLH2012T-15N□-N	15	J, K		15	17	48	2000	0.40	300
CLH2012T-18N□-N	18	J, K		15	17	43	1750	0.45	300
CLH2012T-22N□-N	22	J, K		15	17	40	1700	0.50	300
CLH2012T-27N□-N	27	J, K		15	18	38	1550	0.55	300
CLH2012T-33N□-N	33	J, K		15	19	35	1350	0.60	300
CLH2012T-39N□-N	39	J, K		18	21	37	1300	0.65	300
CLH2012T-47N□-N	47	J, K		18	21	38	1200	0.70	300
CLH2012T-56N□-N	56	J, K		18	21	31	1150	0.75	300
CLH2012T-68N□-N	68	J, K		18	21	28	1000	0.80	300
CLH2012T-82N□-N	82	J, K		18	22	16	850	0.90	300
CLH2012T-R10□-N	100	J, K		18	23		730	1.00	300
CLH2012T-R12□-N	120 *	J, K	13	16	22		650	1.20	300
CLH2012T-R15□-N	150 *	J, K	13	16	22		550	1.40	300
CLH2012T-R18□-N	180 *	J, K	13	16	23		500	1.80	300
CLH2012T-R22□-N	220 *	J, K	12	14	20		450	2.00	300
CLH2012T-R27□-N	270 *	J, K	12	14	20		400	2.50	200
CLH2012T-R33□-N	330 *	J, K	12	14	22		380	3.00	200

Note : * at 50MHz

Tolerance : □- S = ±0.3nH J = ±5% K = ±10%

Test Conditions : Agilent E4991A Agilent 16197A

SRF - HP8753D

RDC - HP4338B/CH502BC



PACKAGING SPECIFICATIONS

Tape Dimensions

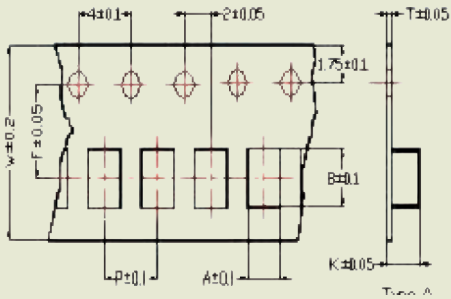

Tape Material

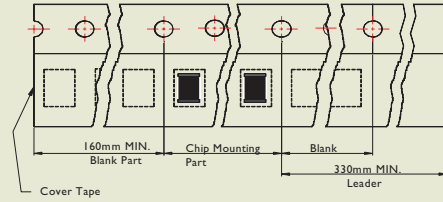

Carrier tape: Polystyrene for 2012
Paper for 1608, 1005

Cover type : Polystyrene

Reel Dimensions

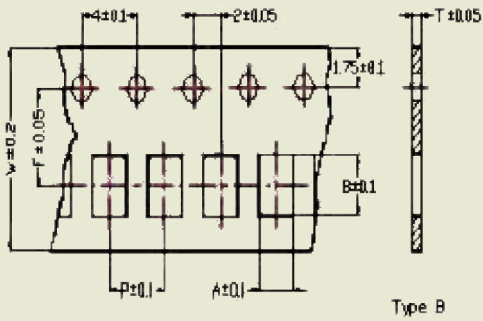
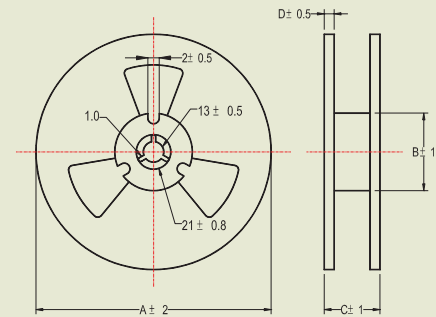

Dimensions : mm

TYPE	Tape Dimensions								Reel Dimensions				Reel Dimensions			Quantity
	Tape	A	B	T	W	P	F	K	A	B	C	D	A	B	C	
CLH1005	B	0.65	1.15	0.60	8	2	3.5		17860	12	1.50	4	1.2 ~ 1.4	0.4	10000	
CLH1608	B	1.00	1.80	0.95	8	4	3.5		17860	12	1.50	8	2.4 ~ 3.4	0.6	4000	
CLH2012	A	1.42	2.25	0.22	8	4	3.5	1.04	17860	12	1.51	2	3.0 ~ 4.0	1.0	4000	



RECOMMEND SOLDERING CONDITIONS

for:CL/ CLH/ SQV/ SMD power inductors/ SMD Chip Beads/ SMD Filters, Transformers, Current Sensors

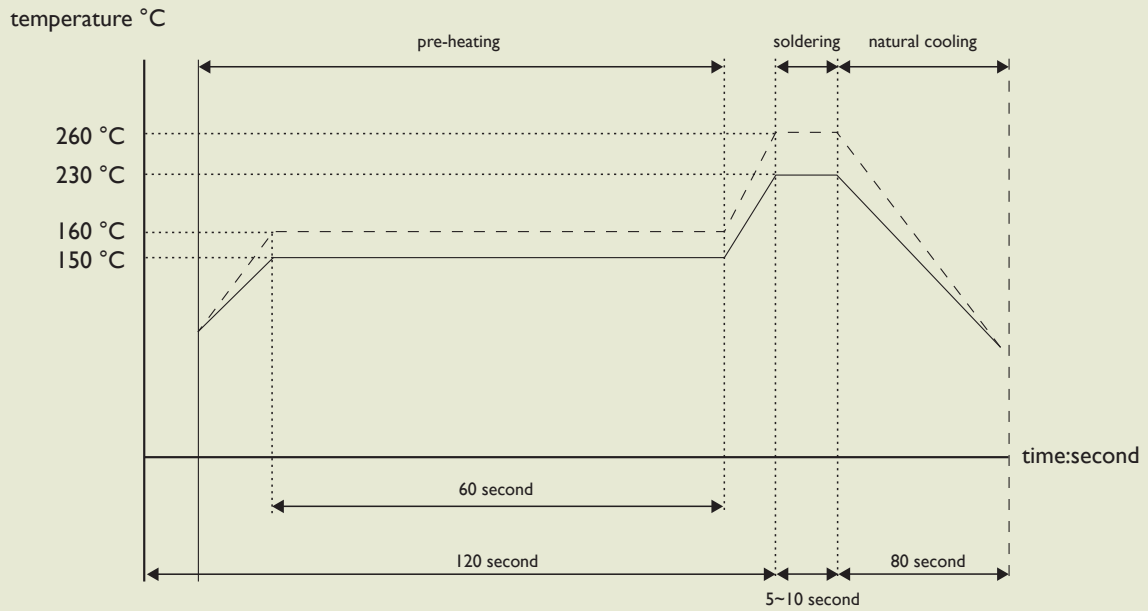

X-ON Electronics

Largest Supplier of Electrical and Electronic Components

Click to view similar products for [Multilayer Ceramic Capacitors MLCC - SMD/SMT](#) category:

Click to view products by [Yageo](#) manufacturer:

Other Similar products are found below :

[M39014/01-1467](#) [M39014/02-1218V](#) [M39014/02-1225V](#) [M39014/02-1262V](#) [M39014/02-1301](#) [M39014/22-0631](#) [1210J5000102JCT](#)
[1210J2K00102KXT](#) [1210J5000103KXT](#) [1210J5000223KXT](#) [D55342E07B379BR-TR](#) [D55342E07B523DR-T/R](#) [1812J1K00103KXT](#)
[1812J1K00473KXT](#) [1812J2K00680JCT](#) [1812J4K00102MXT](#) [1812J5000102JCT](#) [1812J5000103JCT](#) [1812J5000682JCT](#) [NIN-FB391JTRF](#)
[NIN-FC2R7JTRF](#) [NPIS27H102MTRF](#) [C1206C101J1GAC](#) [C1608C0G1E472JT000N](#) [C2012C0G2A472J](#) [2220J2K00101JCT](#)
[KHC201E225M76N0T00](#) [LRC-LRF1206LF-01R025FTR1K](#) [1812J1K00222JCT](#) [1812J2K00102KXT](#) [1812J2K00222KXT](#)
[1812J2K00472KXT](#) [2-1622820-7-CUT-TAPE](#) [2220J3K00102KXT](#) [2225J2500824KXT](#) [CCR07CG103KM](#) [CGA2B2C0G1H010C](#)
[CGA2B2C0G1H040C](#) [CGA2B2C0G1H050C](#) [CGA2B2C0G1H060D](#) [CGA2B2C0G1H070D](#) [CGA2B2C0G1H151J](#) [CGA2B2C0G1H1R5C](#)
[CGA2B2C0G1H2R2C](#) [CGA2B2C0G1H3R3C](#) [CGA2B2C0G1H680J](#) [CGA2B2C0G1H6R8D](#) [CGA2B2X8R1H221K](#) [CGA2B2X8R1H472K](#)
[CGA3E1X7R1C474K](#)