

DATA SHEET

CURRENT SENSOR - LOW TCR

PE Series - Wide Terminal

5%, 1%, 0.5%

RoHS compliant & Halogen free



SCOPE

This specification describes PE series wide-terminal current sensor - low TCR chip resistors made by metal alloy process.

APPLICATIONS

- Battery pack
- Inverter/converter (DC-DC/AC-DC/DC-AC)
- Consumer electronics
- Laptops
- Automotive
- Alternative Energy

FEATURES

- AEC-Q200 qualified
- This product with lead-free terminations meet RoHS requirements
- High component and equipment reliability
- Ultra low resistance and narrow tolerance suitable for current detection

ORDERING INFORMATION - GLOBAL PART NUMBER

Global part numbers are identified by the series, size, tolerance, packing type, temperature coefficient, taping reel and resistance value.

GLOBAL PART NUMBER

PE XXXX X X X XX XXXX L
 (1) (2) (3) (4) (5) (6) (7)

(1) SIZE

0508/0612/0815

(2) TOLERANCE

D = ±0.5% (by request) F = ±1% J = ±5%

(3) PACKAGING TYPE

R = Paper taping reel
 K= Embossed taping reel

(4) TEMPERATURE COEFFICIENT OF RESISTANCE

E = ±50 ppm/°C
 M = ±75 ppm/°C
 F = ±100 ppm/°C
 L = ±150 ppm/°C

(5) TAPING REEL

07/7W = 7 inch dia. Reel and specific rated power. Detailed power ratings are shown in the Table 2

(6) RESISTANCE VALUE

0R001 (1 mΩ) ~ 1R (1Ω)

There are 3~5 digits indicated the resistance value. Letter R is decimal point.

(7) DEFAULT CODE

L = system default code for ordering only

ORDERING EXAMPLE

The ordering code of a PE0508 1W chip resistor, value 0.01 Ω with ±1% tolerance TCR ±75 ppm/°C, supplied in 7-inch tape reel with 5Kpcs quantity is: PE0508FRM070R01L.

NOTE

I. All our RSMD products are RoHS compliant. "LFP" of the internal 2D reel label mentions "Lead-Free Process"

MARKING

PE0508



No marking

Fig. 1 Value = 10 mΩ

PE0612/0815

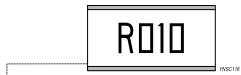

4 digits

The "R" is used as a decimal point; the other 3 digits are significant.

Fig. 2 Value = 10 mΩ

CONSTRUCTION

The resistors are constructed using outstanding TCR level material, which makes Yageo PE resistors excellent for current sensing application.

The composition of the resistive material is adjusted to give the approximate required resistance and is covered with a protective coating. Marking is printed on the top side of the resistor.

Finally, the three external terminations (Cu / Ni / matte Tin) are added, as shown in Fig. 3.

Outlines

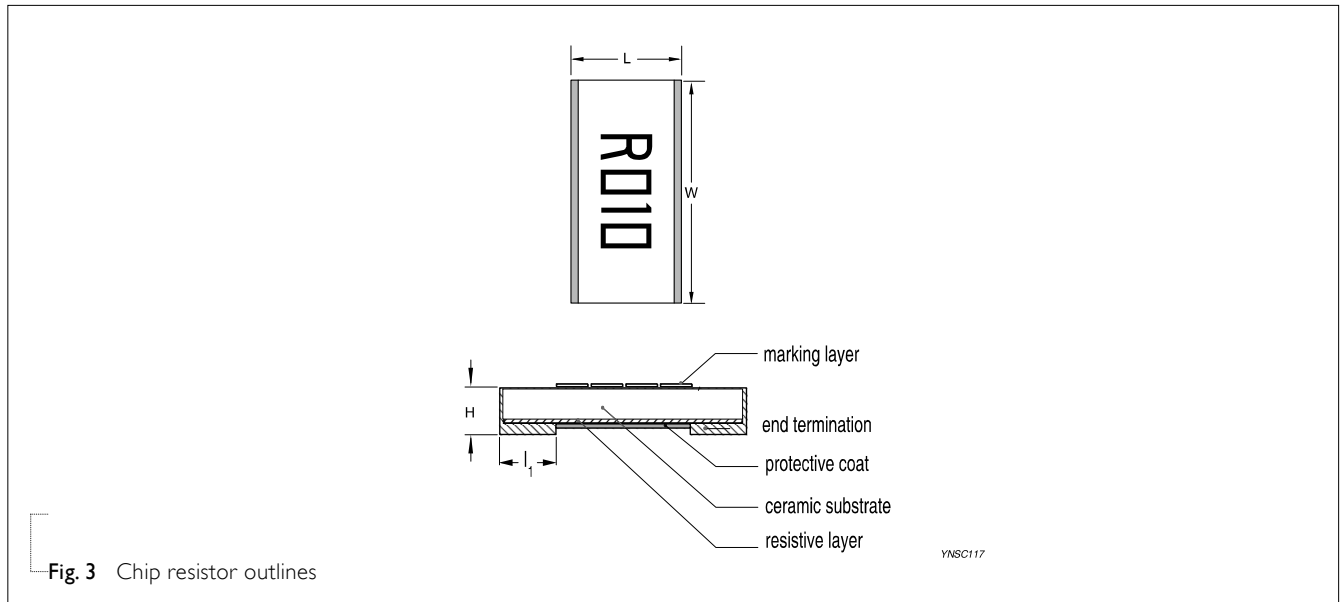

Fig. 3 Chip resistor outlines

DIMENSION

Table 1

| TYPE | RESISTANCE RANGE | L (mm) | W (mm) | H (mm) | l ₁ (mm) |
|--------|------------------|-----------|-----------|-----------|---------------------|
| PE0508 | 5 mΩ ≤ R ≤ 1 Ω | 1.25±0.10 | 2.00±0.10 | 0.55±0.15 | 0.35±0.15 |
| | 1 mΩ | 1.60±0.20 | 3.20±0.20 | 0.60±0.15 | 0.55±0.20 |
| PE0612 | 2 mΩ ≤ R ≤ 4 mΩ | 1.60±0.20 | 3.20±0.20 | 0.60±0.15 | 0.40±0.15 |
| | 5 mΩ ≤ R ≤ 1 Ω | 1.60±0.20 | 3.20±0.20 | 0.60±0.15 | 0.30±0.15 |
| PE0815 | 1 mΩ ≤ R ≤ 2 mΩ | 2.00±0.20 | 3.70±0.20 | 0.60±0.15 | 0.50±0.20 |
| | 3 mΩ ≤ R ≤ 20 mΩ | 2.00±0.20 | 3.70±0.20 | 0.60±0.15 | 0.60±0.20 |

Note:

- For relevant physical dimensions, please refer to construction outlines.
- Please contact with sales offices, distributors and representatives in your region before ordering.

ELECTRICAL CHARACTERISTICS

Table 2

| TYPE | POWER RATING ⁽¹⁾ | | TOLERANCE | RESISTANCE RANGE | TEMPERATURE COEFFICIENT OF RESISTANCE |
|--------|-----------------------------|-----|---------------------|------------------|---------------------------------------|
| | 07 | 7W | | | |
| PE0508 | | --- | ± 0.5% (By request) | 5 mΩ ≤ R < 75 mΩ | ±100ppm/°C |
| | | | | 75 mΩ ≤ R ≤ 1 Ω | ±50ppm/°C |
| PE0612 | | --- | ±1% ±5% | 1 mΩ | ±150ppm/°C |
| | | | | 2 mΩ | ±100ppm/°C |
| | | | | 3 mΩ ≤ R ≤ 1 Ω | ±50ppm/°C, ±75ppm/°C, ±100ppm/°C |
| PE0815 | 1/2W | 1W | | 1 mΩ ≤ R ≤ 20 mΩ | ±75ppm/°C ±100ppm/°C |

Note: 1. Global part number (code 10 - 11)

- Please contact with sales offices, distributors and representatives in your region before ordering.

FUNCTIONAL DESCRIPTION

OPERATING TEMPERATURE RANGE

Range: -55°C to +155°C

POWER RATING

Standard rated power at 70°C:

PE0508 = 1W

PE0612 = 1W

PE0815 = 1/2W; 1W

RATED VOLTAGE

The DC or AC (rms) continuous working voltage corresponding to the rated power is determined by the following formula:

$$V = \sqrt{P \cdot R}$$

Where

V = Continuous rated DC or AC (rms) working voltage (V)

P = Rated power (W)

R = Resistance value (Ω)

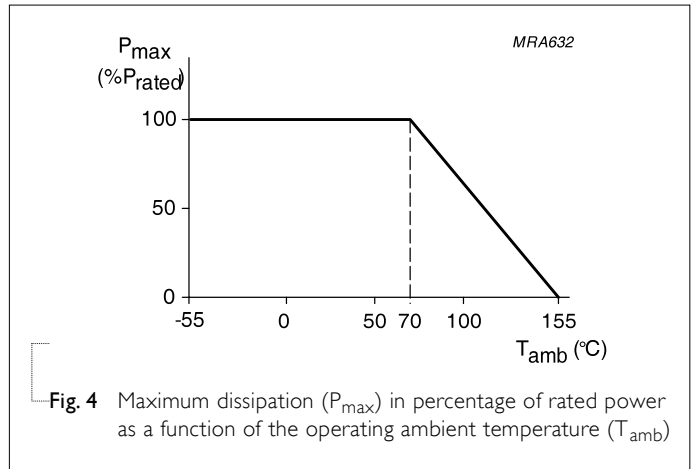

PACKING STYLE AND PACKAGING QUANTITY

Table 3 Packing style and packaging quantity

| PACKING STYLE | REEL DIMENSION | PE0508 | PE0612 | PE0815 |
|--------------------------|----------------|--------|--------|--------|
| Paper taping reel (R) | 7" (178 mm) | 5,000 | --- | --- |
| Embossed taping reel (K) | 7" (178 mm) | --- | 5000 | 4000 |

PAPER TAPE

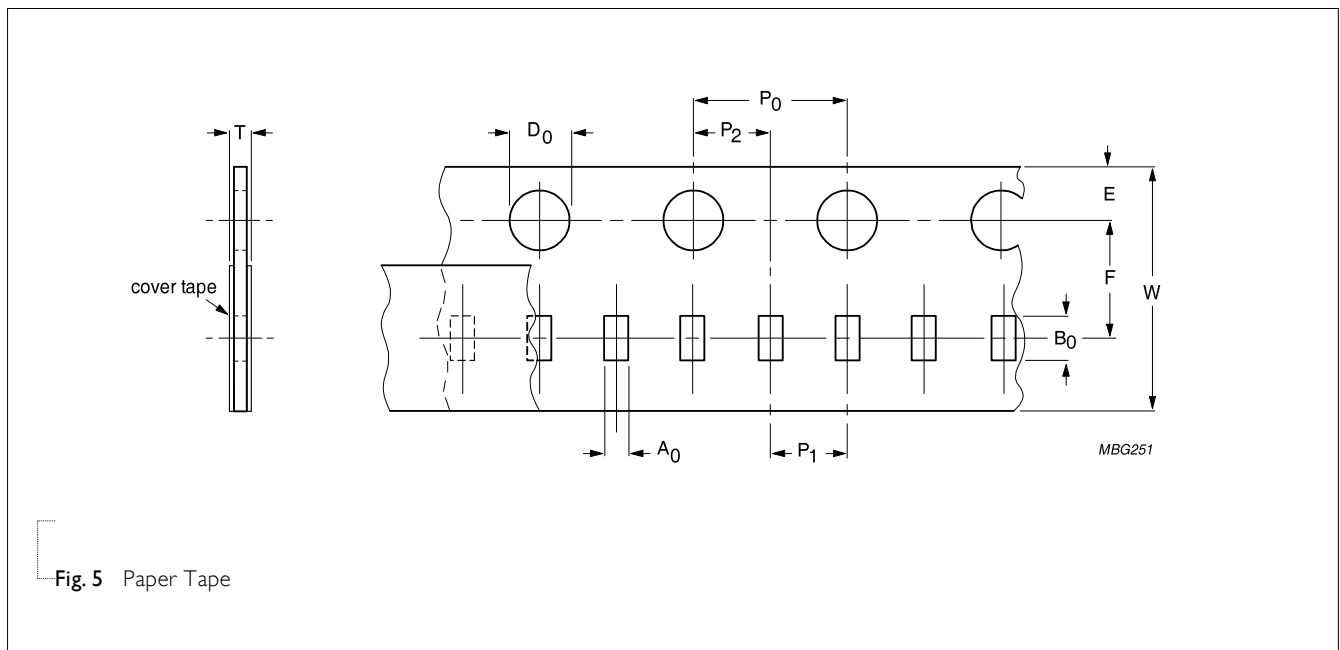

Fig. 5 Paper Tape

Table 4 Dimensions of paper tape for relevant chip resistors size

| SIZE | SYMBOL | | | | | | | | | | Unit: mm |
|--------|----------------|----------------|-----------|-----------|-----------|----------------|----------------|----------------|-----------------|------------|----------|
| | A ₀ | B ₀ | W | E | F | P ₀ | P ₁ | P ₂ | ØD ₀ | T | |
| PE0508 | 1.50± 0.15 | 2.25± 0.15 | 8.00±0.30 | 1.75±0.10 | 3.50±0.10 | 4.00±0.10 | 4.00±0.10 | 2.00±0.10 | 1.50±0.10 | 0.75± 0.15 | |

EMBOSSED TAPE

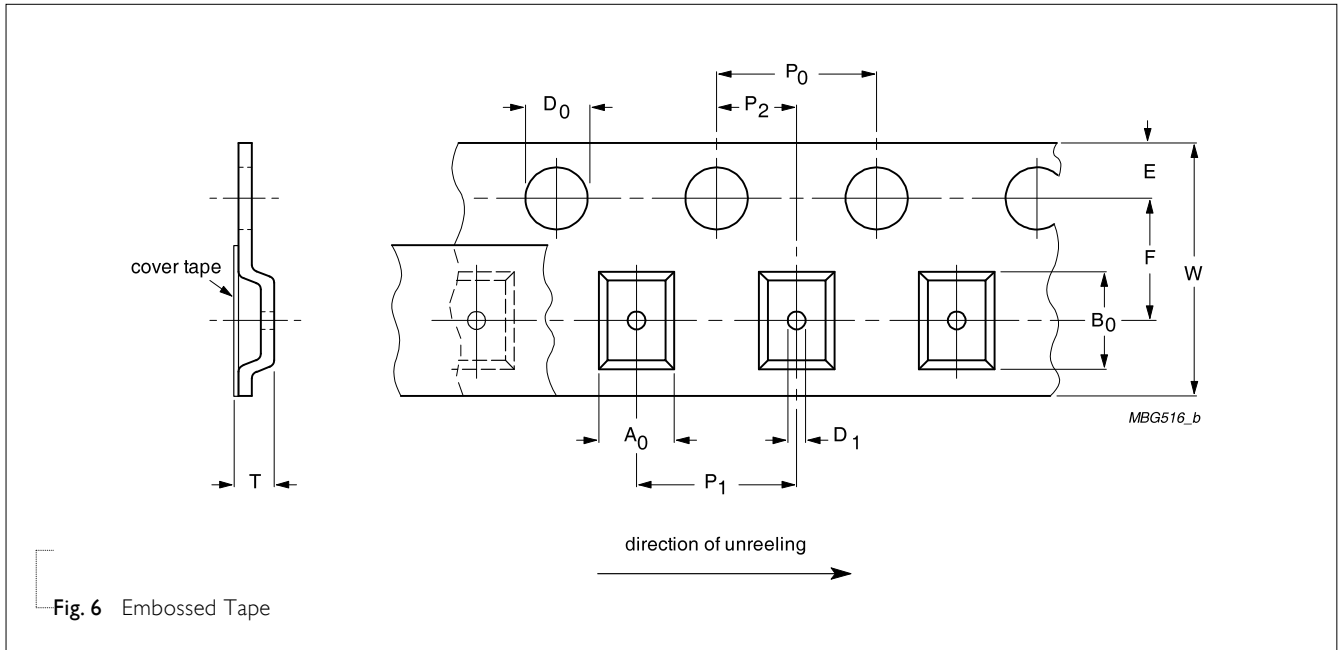

Fig. 6 Embossed Tape

Table 5 Dimensions of embossed tape for relevant chip resistors size

| SIZE | SYMBOL | | | | | | | | | | | Unit: mm |
|--------|----------------|----------------|------------|-----------|-----------|----------------|----------------|----------------|-----------------|----------------|------------|----------|
| | A ₀ | B ₀ | W | E | F | P ₀ | P ₁ | P ₂ | ØD ₀ | D ₁ | T | |
| PE0612 | 1.80±0.15 | 3.52± 0.15 | 8.00±0.30 | 1.75±0.10 | 3.50±0.10 | 4.00±0.10 | 4.00±0.10 | 2.00±0.10 | 1.50±0.10 | 1.50±0.10 | 0.75± 0.15 | |
| PE0815 | 2.25±0.15 | 4.00± 0.15 | 12.00±0.30 | 1.75±0.10 | 5.50±0.10 | 4.00±0.10 | 4.00±0.10 | 2.00±0.10 | 1.50±0.10 | 1.50±0.10 | 0.75± 0.15 | |

REEL SPECIFICATION

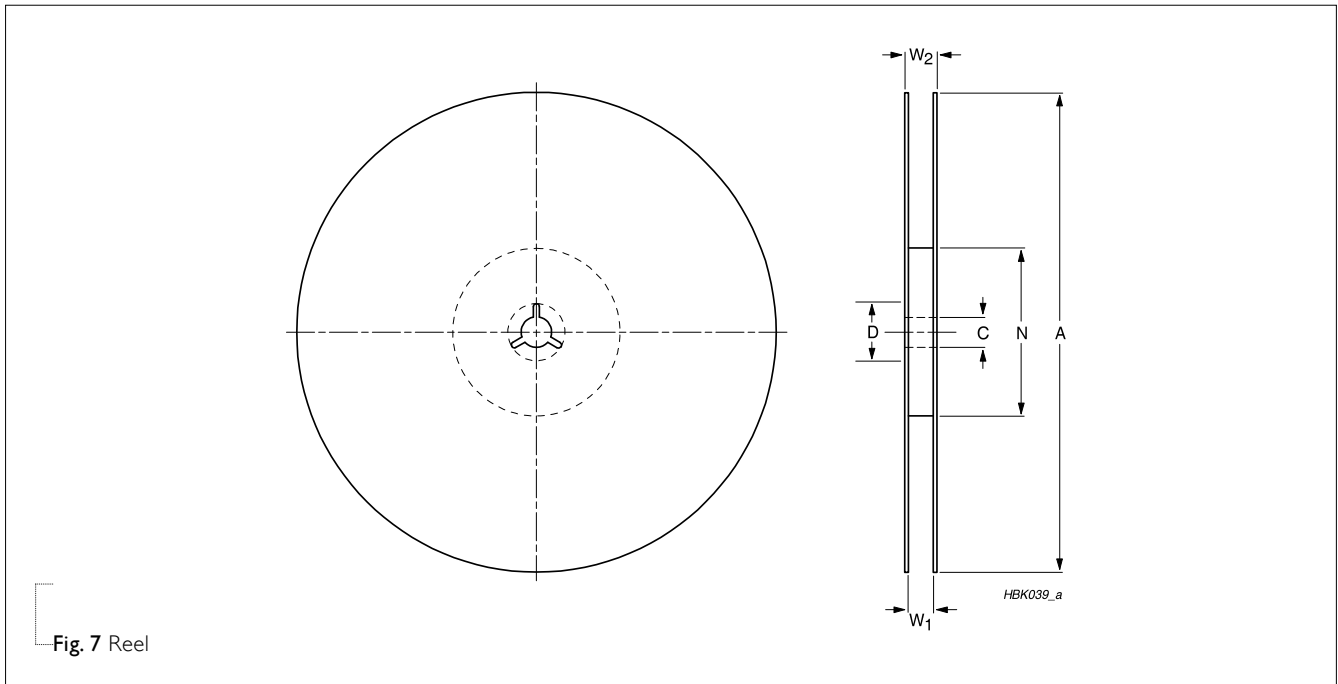

Table 6 Dimensions of reel specification for relevant chip resistors size

| SIZE | SYMBOL | Unit: mm | | | | | |
|--------|--------------|-------------------|-----------|-----------|-----------|-----------|----------------|
| | | 8 mm TAPE WIDE | A | N | C | D | W ₁ |
| PE0508 | 7" (∅178 mm) | 178.0±5 | 60.0+1/-0 | 13.00±0.5 | 17.70±0.5 | 8.4 +1/-0 | 12.4±1 |
| PE0612 | 7" (∅178 mm) | 178.0±5 | 60.0+1/-0 | 13.00±0.5 | 17.70±0.5 | 8.4 +1/-0 | 12.4±1 |

| SIZE | SYMBOL | Unit: mm | | | | | |
|--------|--------------|--------------------|------------|-----------|-----------|------------|----------------|
| | | 12 mm TAPE WIDE | A | N | C | D | W ₁ |
| PE0815 | 7" (∅178 mm) | 178.0 ±5 | 60.0 +1/-0 | 13.00±0.5 | 17.70±0.5 | 12.3 +1/-0 | 18.4±1 |

SOLDERING PROFILES

For recommended soldering profiles, please refer to data sheet “Chip resistors mounting”.

FOOTPRINT

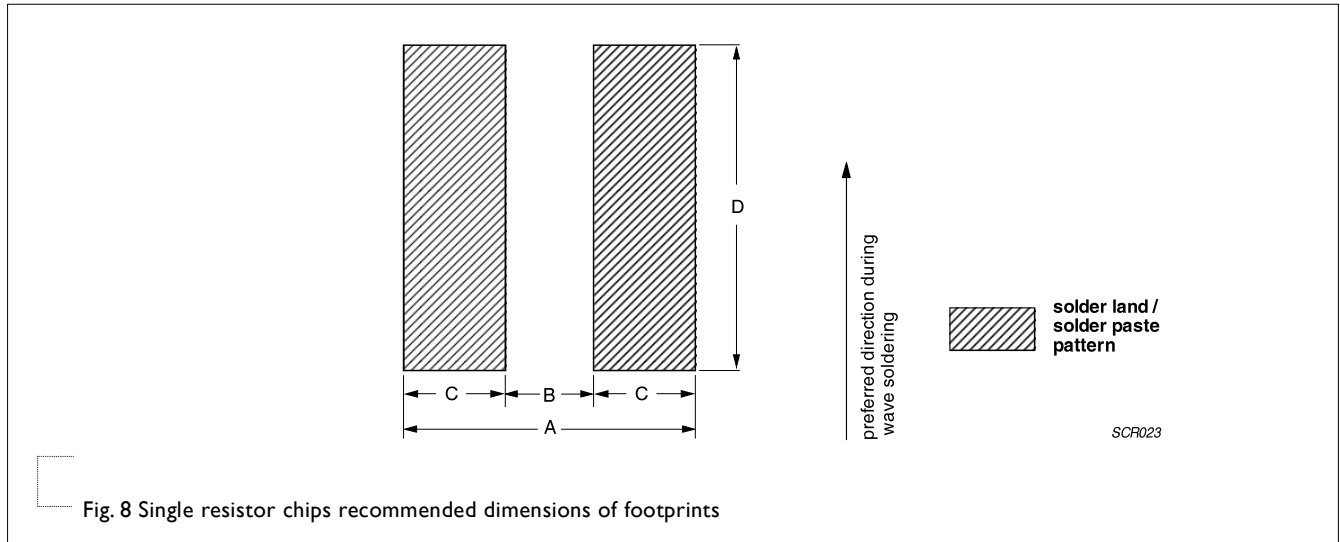

Table 7 Footprint dimensions

| SIZE | RESISTANCE RANGE | Unit: mm | | | |
|--------|--|-----------|-----------|------|------|
| | | A | B | C | D |
| PE0508 | $5\text{ m}\Omega \leq R \leq 1\Omega$ | 1.80~2.00 | 0.40~0.60 | 0.70 | 2.00 |
| PE0612 | $1\text{ m}\Omega \leq R \leq 4\text{m}\Omega$ | 4.60 | 0.40 | 2.10 | 3.68 |
| | $5\text{ m}\Omega \leq R \leq 1\Omega$ | 4.60 | 0.60 | 2.00 | 3.68 |
| PE0815 | $1\text{m}\Omega \leq R \leq 20\text{m}\Omega$ | 3.38 | 0.58 | 1.40 | 4.20 |

TESTS AND REQUIREMENTS
Table 8 Test condition, procedure and requirements

| TEST | TEST METHOD | PROCEDURE | REQUIREMENTS |
|---|------------------------|--|---------------------------------------|
| Life/ Operational Life/ Endurance | IEC 60115-1 4.25.1 | 1,000 hours at 70±5 °C applied RCWV 1.5 hours on, 0.5 hour off, still air required | ±(1%+0.0005 Ω) |
| High Temperature Exposure/ Endurance at Upper Category Temperature | IEC 60068-2-2 | 1,000 hours at maximum operating temperature depending on specification, unpowered No direct impingement of forced air to the parts Tolerances: 155±5 °C | ±(1%+0.0005 Ω) |
| Moisture Resistance | MIL-STD-202 Method 106 | Each temperature / humidity cycle is defined at 8 hours (method 106F), 3 cycles / 24 hours for 10d with 25 °C / 65 °C 95% R.H, without steps 7a & 7b, unpowered Parts mounted on test-boards, without condensation on parts Measurement at 24±2 hours after test conclusion | ±(0.5%+0.0005 Ω) |
| Short Time Overload | IEC60115-1 4.13 | 5 times of rated power for 5 seconds at room temperature | ±(0.5%+0.0005 Ω) No visible damage |
| Board Flex/ Bending | IEC60068-2-21 | Device mounted on 90mm glass epoxy resin PCB test board (FR4), 2 mm bending Bending time: 60±5 seconds | ±(1%+0.0005 Ω) No visible damage |

| TEST | TEST METHOD | PROCEDURE | REQUIREMENTS |
|-----------------------------------|-------------------|--|---|
| Solderability - Wetting | J-STD-002B test B | Electrical Test not required Magnification 50X SMD conditions: 1 st step: method B, aging 4 hours at 155 °C dry heat 2 nd step: leadfree solder bath at 245±3 °C Dipping time: 3±0.5 seconds | Well tinned (≥95% covered) No visible damage |
| - Resistance to Soldering Heat | IEC 60068-2-58 | Condition B, no pre-heat of samples Leadfree solder, 260 °C, 10±1 seconds immersion time Procedure 2 for SMD: devices fluxed and cleaned with isopropanol | ±(0.5%+0.0005 Ω) No visible damage |

REVISION HISTORY

| REVISION | DATE | CHANGE NOTIFICATION | DESCRIPTION |
|-----------|---------------|---------------------|---|
| Version 0 | Dec. 03, 2018 | - | - New datasheet for current sensor - low TCR wide terminal PE series with lead-free terminations. |

“Yageo reserves all the rights for revising the content of this datasheet without further notification, as long as the products itself are unchanged. Any product change will be announced by PCN.”

X-ON Electronics

Largest Supplier of Electrical and Electronic Components

Click to view similar products for [Current Sense Resistors - SMD category](#):

Click to view products by [Yageo manufacturer](#):

Other Similar products are found below :

[CRL0603-FW-R700ELF](#) [65709-330JE](#) [PF2512FKF7W0R007L](#) [PR2512FKF7W0R003L](#) [PR2512FKF7W0R005L](#) [PF2512FKF7W0R006L](#)
[PF2512FKF7W0R033L](#) [CD2015FC-0.10-1%](#) [PR2512FKF7W0R004L](#) [RC1005F124CS](#) [RL73K3AR56JTDF](#) [RL7520WT-R001-F](#)
[RL7520WT-R009-G](#) [RL7520WT-R020-F](#) [RLP73N1ER43JTD](#) [LRC-LR2512LF-01-R820J](#) [WR06X104JGLJ](#) [TL2BR01F](#) [65709-330](#) [SP1R12J](#)
[RL7520WT-R039-G](#) [PF1206FRF7W0R02L](#) [RL7520WT-R002-F](#) [RL7520WT-R047-F](#) [RL7520WT-R005-F](#) [KRL1632E-C-R200-F-T5](#)
[KRL1632E-C-R200-F-T1](#) [Y14880R02000B9R](#) [RLP73M1ER051FTDF](#) [RLP73M2AR051FTDF](#) [RLP73M2AR075FTDF](#) [RLP73K2A1R0FTDF](#)
[RLP73M1JR051FTDF](#) [RLP73N1JR47FTDF](#) [SR731ERTTP5R10F](#) [SR731ERTTP100J](#) [SR731ERTTP6R80F](#) [SR731ERTTP4R70F](#)
[SR731ERTTP2R20F](#) [SR731ERTTP3R90F](#) [SR731ERTTP1R00F](#) [SR731ERTTP10R0F](#) [SR731ERTTP2R00F](#) [SR731ERTTP8R20F](#)
[SR731ERTTP3R9J](#) [SR731ERTTP8R2J](#) [SR731ERTTP2R0J](#) [SR731ERTTP4R7J](#) [SR731ERTTP9R1J](#) [SR731ERTTP1R0J](#)