

# DATA SHEET

## SHUNT RESISTOR AUTOMOTIVE GRADE

PU series

5%, 1%

sizes

2512/ 3921/ 5931

RoHS compliant & Halogen free



**SCOPE**

This specification describes shunt resistor PU series made by welding technology.

**APPLICATIONS**

- Power
- Telecom base station
- Automotive (Headlight/ Window control/ Engine control unit/ Steering control...)
- Alternative energy

**FEATURES**

- AEC-Q200 qualified
- Total lead free without RoHS exemption
- Resistance value down to 0.0001Ω and high power up to 15W
- Welding metal plate construction

YAGEO will eliminate the resistance value marking on the PU5931 on Feb 6th, 2022 and the samples without marking will be available on Aug 16th, 2021. The Product Change Notification number is [EBR-0176-21071601](#).

**ORDERING INFORMATION - GLOBAL PART NUMBER**

Global part numbers are identified by the series, size, tolerance, packing type, temperature coefficient, taping reel and resistance value.

**GLOBAL PART NUMBER**

**PU XXXX X X X XX XXXX L**  
 (1) (2) (3) (4) (5) (6) (7)

**(1) SIZE**

2512/ 3921/ 5931

**(2) TOLERANCE**

F = ±1% J = ±5%

**(3) PACKAGING TYPE**

K = Embossed taping reel

**(4) TEMPERATURE COEFFICIENT OF RESISTANCE**

M = ±75 ppm/°C

N = ±175 ppm/°C

G = ±200 ppm/°C

H = ±225 ppm/°C

I = ±300 ppm/°C

O = ±325 ppm/°C

**(5) TAPING REEL**

I3 = 13 inch Dia. reel, standard power, 4W for 2512, 3W for 3921 and 5W for 5931

P5 = 5W, 13 inch Dia. reel

P6 = 6W, 13 inch Dia. Reel

P7 = 7W, 13 inch Dia. reel

P9 = 9W, 13 inch Dia. reel

T3 = 3W, High temperature 13 inch Dia. reel

T5 = 5W, High temperature 13 inch Dia. reel

PA = 10W, 13 inch Dia. Reel

PB = 15W, 13 inch Dia. Reel

PC = 12W, 13 inch Dia. Reel

**(6) RESISTANCE VALUE**

0.1 mΩ to 5 mΩ

There are 3~5 digits indicated the resistance value. Letter R/ U is decimal point.

Detailed coding rules of resistance are shown in the table of "Resistance rule of global part number".

**(7) DEFAULT CODE**

Letter L is the system default code for ordering only. (Note)

Resistance rule of global part number	
Resistance code rule	Example
0RXXX	0R001 = 1 mΩ
0UX	0U2 = 0.0002 Ω

**ORDERING EXAMPLE**

The ordering code of a PU3921, value 0.0005Ω with ±1% tolerance, 3W and high temperature(275°C) supplied in 13-inch tape reel is :  
**PU3921FKNT30U5L**

**NOTE**

1. All our RSMD products are RoHS compliant. "LFP" of the internal 2D reel label mentions "Lead-Free Process"

**MARKING**

**PU2512**

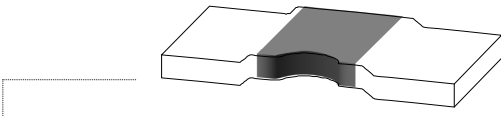

No marking

Fig. 1 Value = 0.2mΩ

**PU3921/ 5931 - 0.1~0.7mΩ**

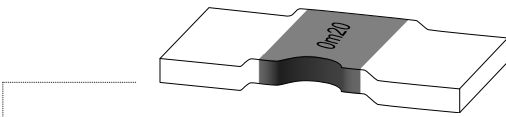

4 digits

The "m" is used as a decimal point ; the other 3 digits are significant and the unit is milliohm

0.1mΩ to 0.7mΩ

Fig. 2 Value = 0.2mΩ

**PU3921/ 5931 - 1~5mΩ**

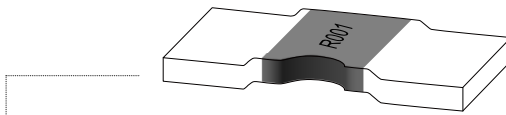

4 digits

The "R" is used as a decimal point ; the other 3 digits are significant

1mΩ to 5mΩ

Fig. 3 Value = 1mΩ

**NOTE:** There will be a short period of time that both types of PU5931, with marking and without marking, exist simultaneously in the market. The exterior of PU5931 without marking is shown in Fig. 1

**OUTLINES AND DIMENSION**

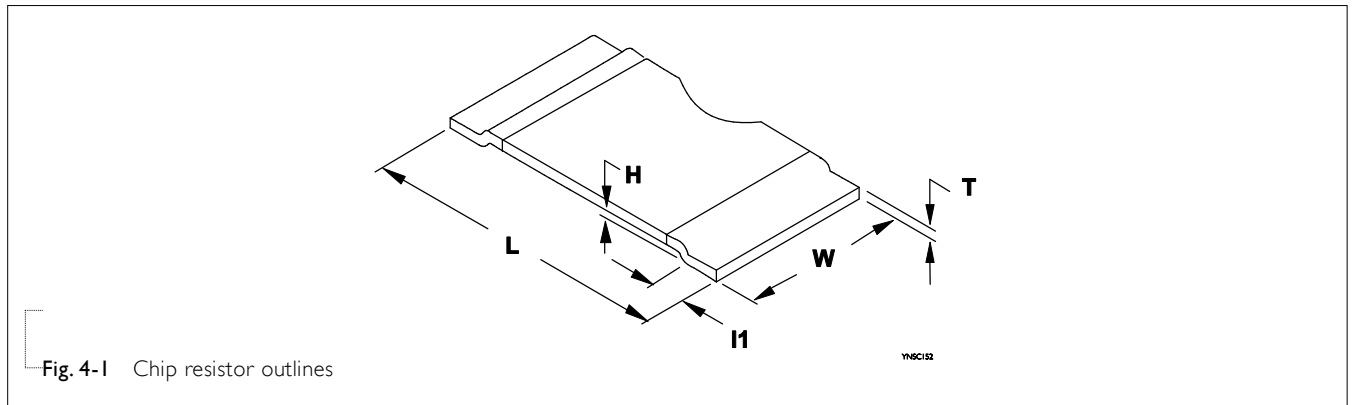

Fig. 4-1 Chip resistor outlines

Table I-1 For outlines, please refer to Fig. 3-1

TYPE	L (mm)	W (mm)	H (mm)	l1 (mm)
PU2512	6.35±0.25	3.18±0.25	0.35±0.15	1.14±0.25
PU3921	10.0±0.25	5.20±0.25	0.50±0.13	2.00±0.25
PU5931	15.0±0.25	7.75±0.25	0.50±0.13	4.00±0.25

Resistance Value	0.1mΩ	0.2mΩ	0.25mΩ	0.3 mΩ	0.4mΩ	0.5 mΩ	0.7 mΩ	1 mΩ	2 mΩ	3 mΩ	4 mΩ	5 mΩ
T (mm)	---	---	---	0.95±0.13	0.75±0.13	0.84±0.13	---	0.43±0.13	0.66±0.13	0.44±0.13	0.33±0.13	0.31±0.13
Thickness	---	1.35±0.13	1.05±0.10	1.35±0.13	1.05±0.13	0.86±0.13	0.60±0.10	0.43±0.13	0.72±0.13	0.48±0.13	0.36±0.13	0.25±0.13
	1.42±0.13	1.33±0.13	---	1.00±0.13	---	0.60±0.13	---	0.33±0.13	0.49±0.13	0.33±0.13	0.25±0.13	---

**ELECTRICAL CHARACTERISTICS**

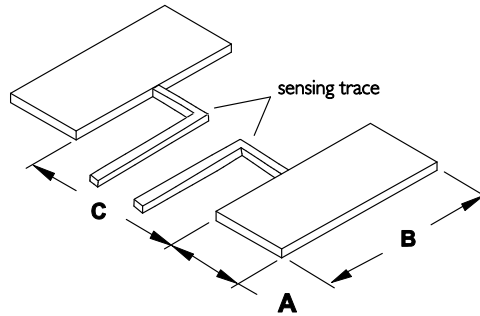

Fig. 4-2 Solder pad dimensions

YAGEO\_1

Note: Series resistors are suitable for IR reflow soldering

Table I-2 For outlines, please refer to Fig. 4-2

TYPE	A (mm)	B (mm)	C (mm)
PU2512	1.80±0.15	3.40±0.15	3.40±0.13
PU3921	2.75±0.25	6.20±0.25	5.60±0.13
PU5931	5.20±0.25	8.75±0.25	5.60±0.13

Table 2

SIZE	POWER RATING <sup>(4)</sup>	OPERATING TEMP. RANGE	RESISTANCE RANGE	TOLERANCE <sup>(2)</sup>	TEMPERATURE COEFFICIENT OF RESISTANCE <sup>(3)</sup>
PU2512	4W(I3)	-65°C to 170°C	3/ 4/ 5mΩ	±1% (F) ±5% (J)	0.3/ 0.4/ 0.5mΩ: ±200ppm/°C (G)
	5W(P5)		1/ 2mΩ		1mΩ: ±175ppm/°C (N)
	6W(P6)		0.3/ 0.4/ 0.5mΩ		2~5mΩ: ±75ppm/°C (M)
PU3921	3W(I3)	-65°C to 170°C	0.2/ 0.25/ 0.3/ 0.4/ 0.5/ 0.7mΩ 1/ 2/ 3/ 4/ 5mΩ	±1% (F) ±5% (J)	0.2/ 0.25/ 0.3/ 0.4/ 0.5/ 0.7mΩ: ±175ppm/°C (N)
	5W(P5)		0.2/ 0.25/ 0.3/ 0.4/ 0.5/ 0.7mΩ 1/ 2/ 3/ 4/ 5mΩ		0.2mΩ: ±325ppm/°C (O)
	9W(P9)		0.2/ 0.25/ 0.3/ 0.4/ 0.5/ 0.7/ 1mΩ		0.2/ 0.25/ 0.3/ 0.4/ 0.5/ 0.7mΩ: ±175ppm/°C (N)
	10W(PA)	-65°C to 275°C	0.2/ 0.3/ 0.5mΩ	±1% (F) ±5% (J)	1~5mΩ: ±75ppm/°C (M)
	12W(PC)				0.2mΩ: ±225ppm/°C (H)
	3W(T3)				0.5mΩ: ±175ppm/°C (N)
PU5931	5W(I3)	-65°C to 170°C	0.2/ 0.3/ 0.5/ 1/ 2/ 3/ 4mΩ	±1% (F) ±5% (J)	0.3/ 0.5mΩ: ±175ppm/°C (N)
	7W(P7)		0.2/ 0.3/ 0.5/ 1/ 2/ 3/ 4mΩ		1~4mΩ: ±75ppm/°C (M)
	10W(PA)	-65°C to 275°C	0.2/ 0.3/ 0.5mΩ	±1% (F) ±5% (J)	0.1mΩ: ±300ppm/°C (I)
	15W(PB)				0.2mΩ: ±225ppm/°C (H)
	5W(T5)				0.3/ 0.5mΩ: ±175ppm/°C (N)
					1~4mΩ: ±75ppm/°C (M)

Note: 1. Please contact with sales offices, distributors and representatives in your region before ordering.

2. Global part number (code7)
3. Global part number (code 9)
4. Global part number (code 10-11)

**FUNCTIONAL DESCRIPTION**

**OPERATING TEMPERATURE RANGE**

High Temperature Range Type:  
-65°C to +275°C (Fig. 5-1)

Normal Temperature Range Type:  
-65°C to +170°C (Fig. 5-2)

**POWER RATING**

Standard rated power at 70°C:

- PU2512 = 4W
- PU3921 = 3W
- PU5931 = 5W

For detail power value, please refer to Table 2.

**RATED VOLTAGE**

The DC or AC (rms) continuous working voltage corresponding to the rated power is determined by the following formula:

$$V = \sqrt{P \times R}$$

Where

V = Continuous rated DC or AC (rms) working voltage (V)

P = Rated power (W)

R = Resistance value ( $\Omega$ )

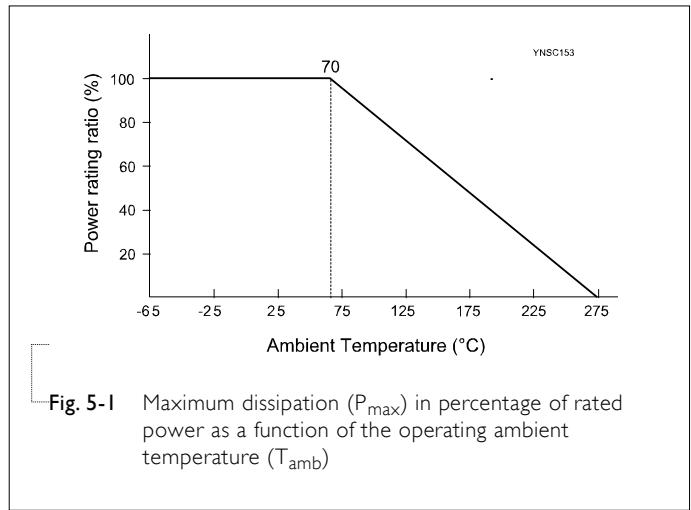

Fig. 5-1 Maximum dissipation ( $P_{max}$ ) in percentage of rated power as a function of the operating ambient temperature ( $T_{amb}$ )

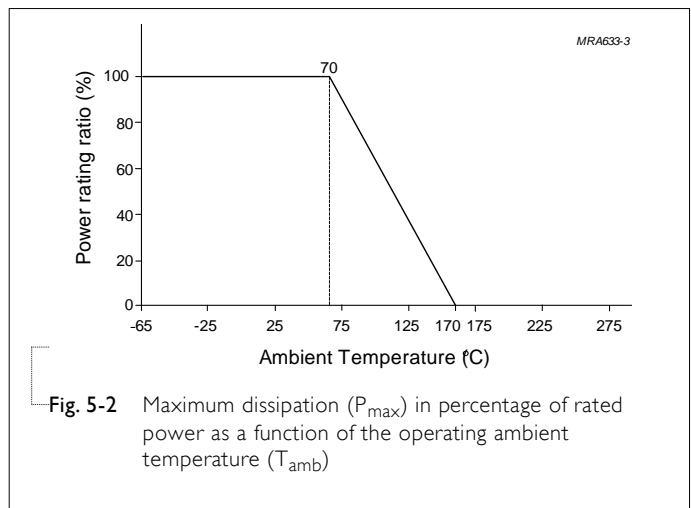

Fig. 5-2 Maximum dissipation ( $P_{max}$ ) in percentage of rated power as a function of the operating ambient temperature ( $T_{amb}$ )

**PACKING STYLE AND PACKAGING QUANTITY**

Table 3 Packing style and packaging quantity

PACKING STYLE	REEL DIMENSION	2512	3921	5931
Embossed taping reel (K)	13" (330 mm)	4,000	3,000	1,500

**EMBOSSED TAPE**

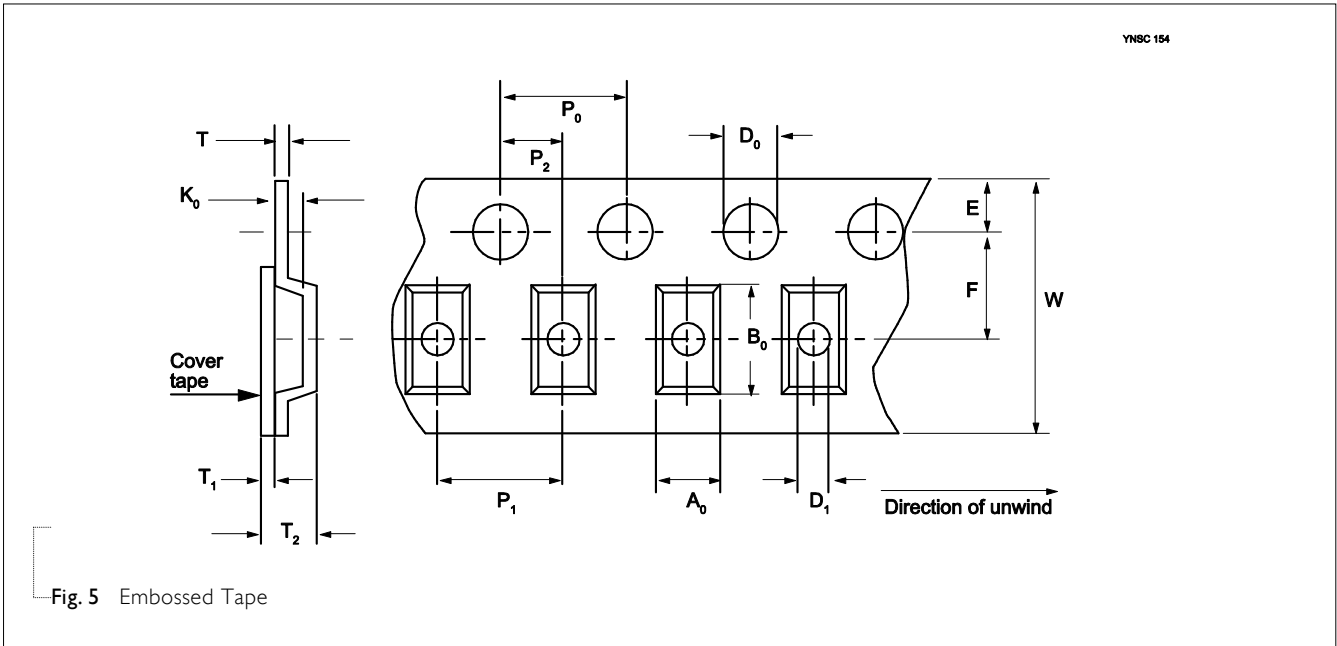

Fig. 5 Embossed Tape

Table 4 Dimensions of embossed tape for relevant chip resistors size

DIMENSION	A <sub>0</sub>	B <sub>0</sub>	D <sub>0</sub>	D <sub>1</sub> MIN.	E	F	K <sub>0</sub> MAX.	P <sub>0</sub>	P <sub>1</sub>	P <sub>2</sub>	T <sub>1</sub> MAX.	T <sub>2</sub> MAX.	T MAX.	W MAX.
<b>PU2512</b>														
0.3/ 0.4 /0.5 /2mΩ	3.58±0.1	6.7±0.1	1.5±0.1	1.5	1.75±0.1	5.5±0.1	1.52	4±0.1	8±0.1	2±0.1	0.1	1.92	0.3	12.3
1 /3 /4 /5mΩ	3.58±0.1	6.7±0.1	1.5±0.1	1.5	1.75±0.1	5.5±0.1	1.14	4±0.1	8±0.1	2±0.1	0.1	1.54	0.3	12.3
<b>PU3921</b>														
0.2/ 0.25/ 0.3/ 0.4 0.5 / 0.7/ 2mΩ	5.59±0.1	10.41±0.1	1.5±0.1	1.5	1.75±0.1	7.5±0.1	2.13	4±0.1	8±0.1	2±0.1	0.1	2.64	0.41	16.3
1 /3 /4 /5mΩ	5.59±0.1	10.41±0.1	1.5±0.1	1.5	1.75±0.1	7.5±0.1	1.14	4±0.1	8±0.1	2±0.1	0.1	1.65	0.41	16.3
<b>PU5931</b>														
≤0.3mΩ	8.3±0.1	15.62±0.1	1.5±0.1	1.5	1.75±0.1	11.5±0.1	2.39	4±0.1	12±0.1	2±0.1	0.1	2.9	0.41	24.3
≥0.5mΩ	8.3±0.1	15.62±0.1	1.5±0.1	1.5	1.75±0.1	11.5±0.1	1.22	4±0.1	12±0.1	2±0.1	0.1	1.73	0.41	24.3

Unit : mm

**REEL SPECIFICATION**

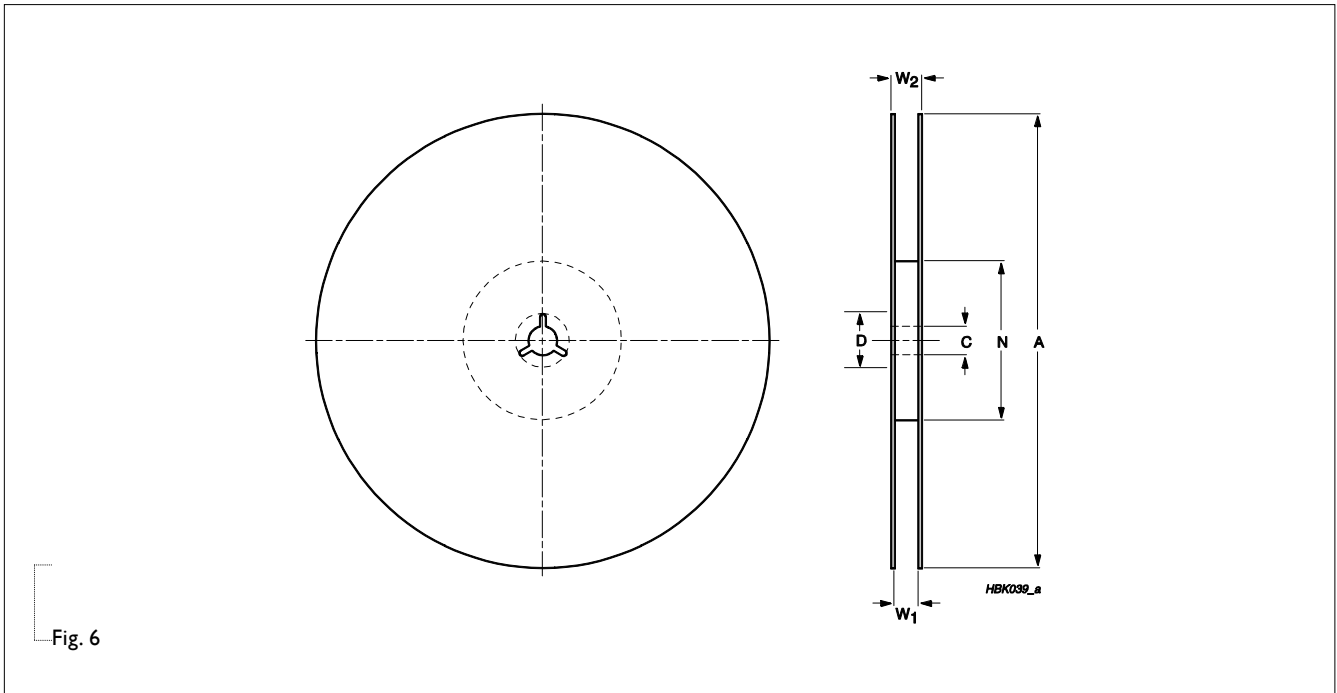

Table 5 Dimensions of reel specification for relevant chip resistors size; see Fig. 6

PRODUCT SIZE CODE	REEL SIZE	SYMBOL					
		A	N	C	D	W1	W2 max.
2512	13" ( $\Phi$ 330mm)	330+0 /-3	100±0.5	13.5±0.5	21±0.8	13±0.3	17.5
3921	13" ( $\Phi$ 330mm)	330+0 /-3	100±0.5	13.5±0.5	21±0.8	16.4+2.0/-0	22.4
5931	13" ( $\Phi$ 330mm)	330+0 /-3	100±0.5	13.5±0.5	21±0.8	24.4+2.0/-0	30.4

Unit : mm

**TESTS AND REQUIREMENTS**

Table 6 Test condition, procedure and requirements

TEST	TEST METHOD	PROCEDURE	REQUIREMENTS
Short Time Overload	IEC60115-1 4.13	5 times of rated power for 5 seconds at room temperature	$\pm(1\%+0.0005 \Omega)$ No visible damage
High Temperature Exposure	AEC-Q200 Test 3 MIL-STD-202 method 108A IEC 60115-1 4.25.3	1,000 hours at maximum operating temperature depending on specification, unpowered, Normal Temperature Range Type: $170\pm 3^{\circ}\text{C}$ High Temperature Range Type: $275\pm 5^{\circ}\text{C}$	$\pm(1\%+0.0005 \Omega)$
Moisture Resistance	AEC-Q200 Test 6 MIL-STD-202 method 106F	Each temperature / humidity cycle is defined at 8 hours (method 106F), 3 cycles / 24 hours for 10d with $25^{\circ}\text{C} / 65^{\circ}\text{C}$ 95% R.H, without steps 7a & 7b, unpowered Parts mounted on test-boards, without condensation on parts Measurement at $24\pm 2$ hours after test conclusion	$\pm(1\%+0.0005 \Omega)$
Biased Humidity	AEC-Q200 Test 7 MIL-STD-202 method 103	1,000 hours; $85^{\circ}\text{C} / 85\% \text{RH}$ 10% of operating power Measurement at $24\pm 4$ hours after test conclusion.	$\pm(1\%+0.0005 \Omega)$
Life/ Operational Life/ Endurance	AEC-Q200 Test 8 MIL-STD-202 method 108A IEC 60115-1 4.25.1	1,000 hours at $70\pm 5^{\circ}\text{C}$ applied RCWV 1.5 hours on, 0.5 hour off, still air required	$\pm(1\%+0.0005 \Omega)$
- Resistance to Soldering Heat	AEC-Q200 Test 15 MIL-STD-202 method 210F IEC 60115-1 4.18	Condition B, no pre-heat of samples Lead free solder, $260^{\circ}\text{C}$ , 10 seconds immersion time Procedure 2 for SMD: devices fluxed and cleaned with isopropanol	$\pm(0.5\%+0.0005 \Omega)$ No visible damage
Thermal Shock	AEC-Q200 Test 16 MIL-STD-202 method 107	$-55/+150^{\circ}\text{C}$ Number of cycles is 300. Maximum transfer time is 20 seconds. Dwell time is 15 minutes. Air – Air	$\pm(1\%+0.0005 \Omega)$ No visible damage
Board Flex / Bending	AEC-Q200 Test 21 AEC-Q200-005	Chips mounted on a 90mm glass epoxy resin PCB (FR4) Bending: 2 mm Holding time: minimum 60 seconds	$\pm(1\%+0.0005 \Omega)$



**REVISION HISTORY**

REVISION	DATE	CHANGE NOTIFICATION	DESCRIPTION
Version 8	Aug. 02, 2021	-	- Notify our clients that YAGEO will eliminate resistance value marking on the PU5931
Version 7	Apr. 15, 2021	-	- Extend resistor value for 2512 and power rating for 3921
Version 6	Apr. 03, 2019	-	- Extend resistor value for 3921
Version 5	Jun. 28, 2018	-	- Update packing quantity for PU2512
Version 4	Nov. 23, 2017	-	- Added in PU2512
Version 3	May 24, 2017	-	- Added in thickness for 3921 0.4mΩ
Version 2	Jan. 16, 2017	-	- Extend resistor value
Version 1	Jun. 15, 2016	-	- Extend resistor value
Version 0	Mar. 16, 2016	-	- New datasheet for shunt resistor PU series

*“Yageo reserves all the rights for revising the content of this datasheet without further notification, as long as the products itself are unchanged. Any product change will be announced by PCN.”*

## X-ON Electronics

Largest Supplier of Electrical and Electronic Components

*Click to view similar products for [Current Sense Resistors - SMD category](#):*

*Click to view products by [Yageo manufacturer](#):*

Other Similar products are found below :

[CRL0603-FW-R700ELF](#) [PFS35-200RF1](#) [NPS 2-T126 5.000 OHM 1%](#) [PFS35-0R01J1](#) [PFS35-0R05J1](#) [PFS35-5RF1](#) [CD2015FC-0.10-1%](#)  
[PR2512FKF7W0R004L](#) [RC1005F124CS](#) [RL73K3AR56JTDF](#) [RL7520WT-R001-F](#) [RL7520WT-R009-G](#) [RL7520WT-R020-F](#) [LRC-](#)  
[LR2512LF-01-R820J](#) [WR06X104JGLJ](#) [TL2BR01F](#) [65709-330](#) [SP1R12J](#) [RL7520WT-R039-G](#) [RL7520WT-R002-F](#) [LRF2010-R003JW](#)  
[KRL1632E-C-R200-F-T5](#) [KRL1632E-C-R200-F-T1](#) [RLP73M1ER051FTDF](#) [RLP73M2AR075FTDF](#) [SR731ERTTP5R10F](#) [SR731ERTTP100J](#)  
[SR731ERTTP6R80F](#) [SR731ERTTP4R70F](#) [SR731ERTTP2R20F](#) [SR731ERTTP3R90F](#) [SR731ERTTP1R00F](#) [SR731ERTTP10R0F](#)  
[SR731ERTTP2R00F](#) [SR731ERTTP8R20F](#) [SR731ERTTP3R9J](#) [SR731ERTTP8R2J](#) [SR731ERTTP2R0J](#) [SR731ERTTP4R7J](#)  
[SR731ERTTP9R1J](#) [SR731ERTTP1R0J](#) [SR731ERTTP2R2J](#) [SR731ERTTP5R1J](#) [SR731ERTTP6R8J](#) [SR731ERTTP9R10F](#) [FCSL64R007JER](#)  
[LRF1206-R018FW](#) [TLR2B10DR022FTDG](#) [TLR2H10DR01FTDG](#) [73L4R10G](#)