

DATA SHEET

THIN FILM CHIP RESISTORS AUTOMOTIVE GRADE

RP series

0.1% TO 1%, TC25 TO TC50
sizes 0402/0603/0805/1206

RoHS compliant



SCOPE

This specification describes RP0402 to RP1206 high precision-high stability chip resistors made by thin film process.

APPLICATIONS

- Automotive electronics
- Industrial and medical equipment
- Test and measuring equipment
- Telecommunications

FEATURES

- AEC-Q200 qualified
- Total lead free without RoHS exemption
- Halogen free epoxy
- Superior resistance against sulfur containing atmosphere
- Moisture sensitivity level: MSL 1
- Reducing environmentally hazardous wastes
- High component and equipment reliability
- Non-forbidden materials used in products/production

ORDERING INFORMATION - GLOBAL PART NUMBER

Part number is identified by the series name, size, tolerance, packaging type, temperature coefficient, taping reel and resistance value.

GLOBAL PART NUMBER

RP XXXX X X X XX XXXXX L
 (1) (2) (3) (4) (5) (6) (7)

(1) SIZE

0402 / 0603 / 0805 / 1206

(2) TOLERANCE

- B = ± 0.1%
- C = ± 0.25%
- D = ± 0.5%
- F = ± 1%

(3) PACKAGING TYPE

R = Paper taping reel

(4) TEMPERATURE COEFFICIENT OF RESISTANCE

- D = ± 25 ppm/°C
- E = ± 50 ppm/°C

(5) TAPING REEL

07 = 7 inch dia. Reel

(6) RESISTANCE VALUE

There are 2~4 digits indicated the resistor value.
 Letter R/K/M is decimal point
 Example: 100R = 100Ω
 1K = 1,000Ω

(7) DEFAULT CODE

Letter L is the system default code for ordering only. (NOTE)

ORDERING EXAMPLE

The ordering code of a RP0402 chip resistor, TC 25 value 56Ω with ± 0.5% tolerance, supplied in 7-inch tape reel is: RP0402DRD0756RL.

NOTE

1. All our Rchip products meet RoHS compliant and Halogen Free. "LFP" of the internal 2D reel label mentions "Lead Free Process".
2. On customized label, "LFP" or specific symbol can be printed.

MARKING

RP0402



No marking

RP0603

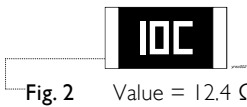

E-96 series: including values 10/11/13/15/20/75 of E-24 series, 3 digits

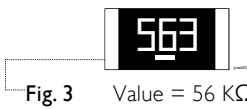

E-24 series: exception values 10/11/13/15/20/75 of E-24 series, one short bar under marking letter

RP0805 / RP1206

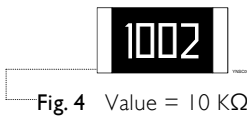

Both E-24 and E-96 series: 4 digits
First three digits for significant figure and 4th digit for number of zeros

NOTE

For further marking information, please see special data sheet “Chip resistors marking”.

CONSTRUCTION

The resistors are constructed out of a high grade ceramic body. Internal metal electrodes are added at each end connected by a resistive layer. This resistive layer is trimmed to its nominal value and on both ends a contact is made which will guarantee optimum solderability. This is achieved by applying several layers and for ease of soldering the outer layer consists of Ni/matte tin. Adding a special protective layer, passivation coating, on this series to enhance moisture resistance of the environment.

OUTLINES

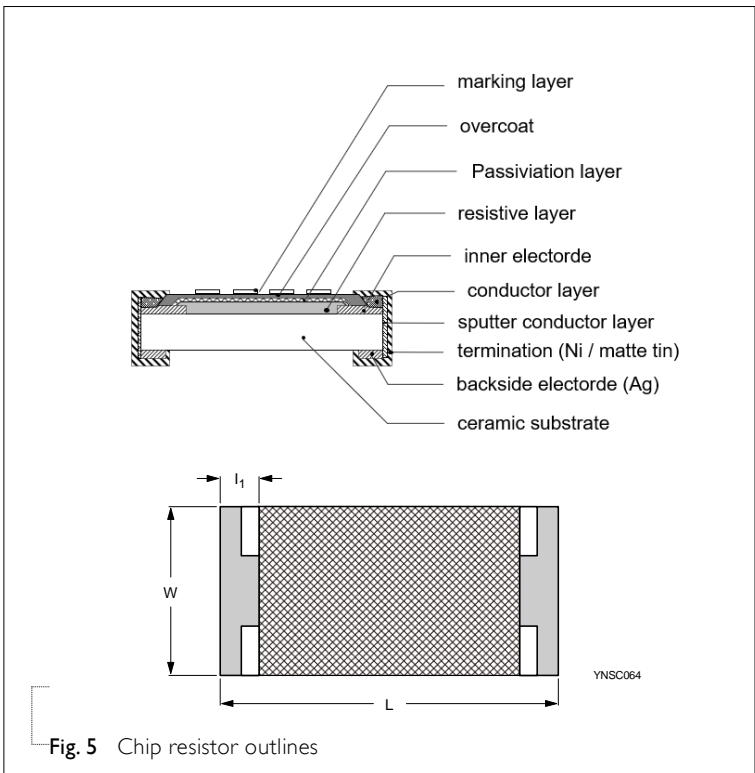

DIMENSIONS

Table 1

TYPE	L (mm)	W (mm)	H (mm)	l ₁ (mm)	l ₂ (mm)
RP0402	1.00 ±0.10	0.50 ±0.05	0.30 ±0.05	0.20 ±0.10	0.25 ±0.10
RP0603	1.60 ±0.10	0.80 ±0.10	0.45 ±0.10	0.25 ±0.15	0.25 ±0.15
RP0805	2.00 ±0.10	1.25 ±0.10	0.50 ±0.10	0.35 ±0.20	0.35 ±0.20
RP1206	3.10 ±0.10	1.60 ±0.10	0.55 ±0.10	0.45 ±0.20	0.40 ±0.20

ELECTRICAL CHARACTERISTICS

Table 2

TYPE	Operating Temperature Range	Power Rating	Max. Working Voltage	Max. Overload Voltage	Resistance Range (E-24/E-96 series)(Ω) & Tolerance ⁽¹⁾				
					T.C.R. (ppm/°C) ⁽²⁾	±0.1% (B)	±0.25% (C)	±0.5% (D)	±1% (F)
RP0402	-55 °C to +155 °C	1/16W	50 V	100 V	±50 (E)	10 ≤ R ≤ 240K			
					±25 (D)	10 ≤ R ≤ 240K			
RP0603	-55 °C to +155 °C	1/10W	75V	150 V	±50 (E)	10 ≤ R ≤ 910K			
					±25 (D)	10 ≤ R ≤ 910K			
RP0805	-55 °C to +155 °C	1/8W	150 V	300 V	±50 (E)	10 ≤ R ≤ 1M5			
					±25 (D)	10 ≤ R ≤ 1M5			
RP1206	-55 °C to +155 °C	1/4W	200 V	400 V	±50 (E)	10 ≤ R ≤ 1M5			
					±25 (D)	10 ≤ R ≤ 1M5			

NOTE : 1. Global part number (code 7)
2. Global part number (code 9)

FOOTPRINT AND SOLDERING PROFILES

For recommended footprint and soldering profiles, please see the special data sheet “Chip resistors mounting”.

PACKING STYLE AND PACKAGING QUANTITY

Table 3 Packing style and packaging quantity

PRODUCT TYPE	PATKING STYLE	REEL DIMENSION	QUANTITY PER REEL
RP0402	Paper taping reel	7" (178 mm)	10,000 Units
RP0603	Paper taping reel	7" (178 mm)	5,000 Units
RP0805	Paper taping reel	7" (178 mm)	5,000 Units
RPI206	Paper taping reel	7" (178 mm)	5,000 Units

NOTE: for paper tape and reel specification/dimensions, please see the special data sheet “packing” document.

FUNCTIONAL DESCRIPTION

OPERATING TEMPERATURE RANGE

Range: -55 °C to +155 °C

POWER RATING

Each type rated power at 70 °C:

- RP0402=1/16 W
- RP0603=1/10 W
- RP0805=1/8 W
- RPI206=1/4 W

RATED VOLTAGE

The DC or AC (rms) continuous working voltage corresponding to the rated power is determined by the following formula:

$$V = \sqrt{(P \times R)}$$

Or max. working voltage whichever is less

Where

V=Continuous rated DC
or AC (rms) working voltage (v)

P=Rated power

R=Resistance value (Ω)

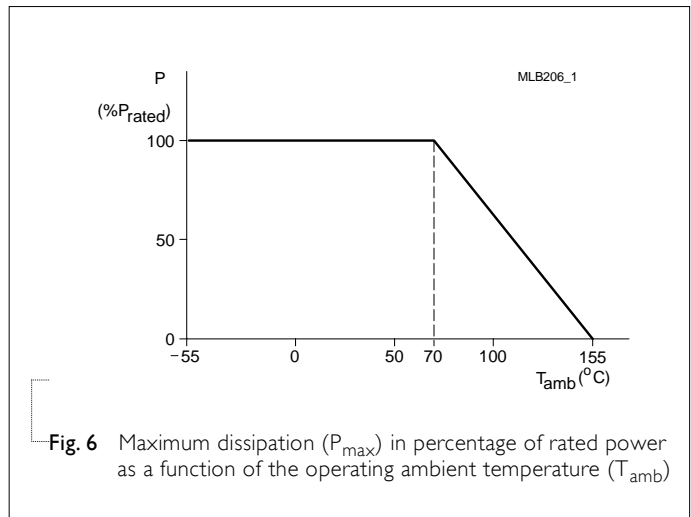

Fig. 6 Maximum dissipation (P_{max}) in percentage of rated power as a function of the operating ambient temperature (T_{amb})

TESTS AND REQUIREMENTS

Table 4 Test condition, procedure and requirements

TEST	TEST METHOD	PROCEDURE	REQUIREMENTS
Short Time Overload	IEC60115-1 4.13	2.5 times of rated voltage or maximum overload voltage, the less of the above, for 5 sec at room temperature	$\pm(0.05\%+0.05\Omega)$
High Temperature Exposure	AEC-Q200 Test 3 MIL-STD-202 Method 108	1,000 hours at Tamb = 155 °C, unpowered	$\pm(0.3\%+0.05\Omega)$
Moisture Resistance	AEC-Q200 Test 6 MIL-STD-202 Method 106	Each temperature / humidity cycle is defined at 8 hours (method 106F), 3 cycles / 24 hours for 10d. with 25 °C / 65 °C 95% R.H, without steps 7a & 7b, unpowered Parts mounted on test-boards, without condensation on parts	$\pm(0.1\%+0.05\Omega)$
Biased Humidity	AEC-Q200 Test 7 MIL-STD-202 Method 103	1,000 hours; 85 °C / 85% RH 10% of operating power Measurement at 24±4 hours after test conclusion	$\pm(0.1\%+0.05\Omega)$
Life	AEC-Q200 Test 8 MIL-STD-202 Method 108	1,000 hours at 70±5 °C, RCWV applied for 1.5 hours on, 0.5 hour off, still air required	$\pm(0.1\%+0.05\Omega)$
Resistance to Soldering Heat	AEC-Q200 Test 15 MIL-STD-202 Method 210	Condition B, no pre-heat of samples Lead-free solder, 260±5 °C, 10±1 seconds immersion time Procedure 2 for SMD: devices fluxed and cleaned with isopropanol	$\pm(0.05\%+0.05\Omega)$
Thermal Shock	AEC-Q200 Test 16 MIL-STD-202 Method 107	-55/+125 °C Number of cycles is 300. Devices mounted Maximum transfer time is 20 seconds. Dwell time is 15 minutes. Air – Air	$\pm(0.1\%+0.05\Omega)$ No visible damage
Solderability - Wetting	AEC-Q200 Test 18 J-STD-002	Electrical Test not required Magnification 50X SMD conditions: (a) Method B, aging 4 hours at 155 °C dry heat, dipping at 235±3 °C for 5±0.5 seconds. (b) Method B, steam aging 8 hours, dipping at 215±3 °C for 5±0.5 seconds. (c) Method D, steam aging 8 hours, dipping at 260±3 °C for 7±0.5 seconds	Well tinned (>95% covered) No visible damage

TEST	TEST METHOD	PROCEDURE	REQUIREMENTS
Board Flex / Bending	AEC-Q200 Test 21 AEC-Q200-005	Chips mounted on a 90mm glass epoxy resin PCB (FR4) Bending for 0402: 5 mm 0603/0805: 3 mm 1206: 2mm Holding time: minimum 60 second	±(0.1%+0.05Ω)
Temperature Coefficient of Resistance (T.C.R.)	IEC 60115-1 4.8	At +25/-55 °C and +25/+125°C Formula: $T.C.R = \frac{R2 - R1}{R1(t2 - t1)} \times 10^6(\text{ppm}/^\circ\text{C})$ Where t1=+25 °C or specified room temperature t2=-55 °C or +125 °C test temperature R1=resistance at reference temperature in ohms R2=resistance at test temperature in ohms	Refer to table 2
Flower of Sulfur	ASTM-B-809-95* * Modified	Sulfur 750 hours, 105°C, unpowered.	±(2.0%+0.05Ω)

REVISION HISTORY

<u>REVISION</u>	<u>DATE</u>	<u>CHANGE NOTIFICATION</u>	<u>DESCRIPTION</u>
Version 0	Jul. 25, 2022	-	- First issue of this specification

LEGAL DISCLAIMER

YAGEO, its distributors and agents (collectively, "YAGEO"), hereby disclaims any and all liabilities for any errors, inaccuracies or incompleteness contained in any product related information, including but not limited to product specifications, datasheets, pictures and/or graphics. YAGEO may make changes, modifications and/or improvements to product related information at any time and without notice.

YAGEO makes no representation, warranty, and/or guarantee about the fitness of its products for any particular purpose or the continuing production of any of its products. To the maximum extent permitted by law, YAGEO disclaims (i) any and all liability arising out of the application or use of any YAGEO product, (ii) any and all liability, including without limitation special, consequential or incidental damages, and (iii) any and all implied warranties, including warranties of fitness for a particular purpose, non-infringement and merchantability.

YAGEO statements regarding the suitability of products for certain types of applications are based on YAGEO's knowledge of typical operating conditions for such types of applications in a generic nature. Such statements are neither binding statements of YAGEO nor intended to constitute any warranty concerning the suitability for a specific customer application or use. They are intended for use only by customers with requisite knowledge and experience for determining whether YAGEO products are the correct products for their application or use. In addition, unpredictable and isolated cases of product failure may still occur, therefore, customer application or use of YAGEO products which requires higher degree of reliability or safety, shall employ additional protective safeguard measures to ensure that product failure would not result in personal injury or property damage.

YAGEO products are not designed for application or use in medical, life-saving, or life-sustaining devices or for any other application or use in which the failure of YAGEO products could result in personal injury or death. Customers using or selling YAGEO products not expressly indicated for above-mentioned purposes shall do so at their own risk and agree to fully indemnify YAGEO and hold YAGEO harmless.

Information provided here is intended to indicate product specifications only. YAGEO reserves all the rights for revising this content without further notification, as long as products are unchanged. Any product change will be announced by PCN.

X-ON Electronics

Largest Supplier of Electrical and Electronic Components

Click to view similar products for [Thin Film Resistors - SMD category](#):

Click to view products by [Yageo manufacturer](#):

Other Similar products are found below :

[D55342E07B379BR-TR](#) [AR03BTC0390](#) [AR03BTC2201](#) [AR03BTC2203](#) [AR03BTC4223N](#) [AR05BTC1523](#) [AR05BTC1760](#) [AR05BTC4201](#)
[AR05BTC5002](#) [AR05BTC5003](#) [AR05BTC6402](#) [AR06BTC1002](#) [AR06BTC1022](#) [AR06BTC1183](#) [AR06BTC1580](#) [AR06BTC1622](#)
[AR06BTC1693](#) [AR06BTC2431](#) [AR06BTC2490](#) [AR06BTC3833](#) [AR06BTC4022](#) [AR06BTC4122](#) [AR06BTC4221](#) [AR06BTC4640](#)
[AR06BTC4872](#) [AR06BTC4991](#) [AR06BTC6041](#) [AR06BTC6203](#) [AR06BTC7151](#) [AR06BTC9001](#) [AR06BTC9091](#) [AR10BTC4701](#) [ERA-](#)
[3EEB2742V](#) [NTR06D2001DTRF](#) [NTR06F1002CTRF](#) [NTR10B1003CTRF](#) [NTR10B4991CTRF](#) [AR02BTC2582](#) [AR02BTC3092](#)
[AR03BTC0820](#) [AR05BTC0270](#) [AR05BTC1563](#) [AR05BTC2503](#) [AR05BTC4001](#) [AR05BTC7960](#) [AR05BTC9001](#) [AR06BTC0360](#)
[AR06BTC1004](#) [AR06BTC1401](#) [AR06BTC1504](#)