

CFP2(CN121 series) Application Specification

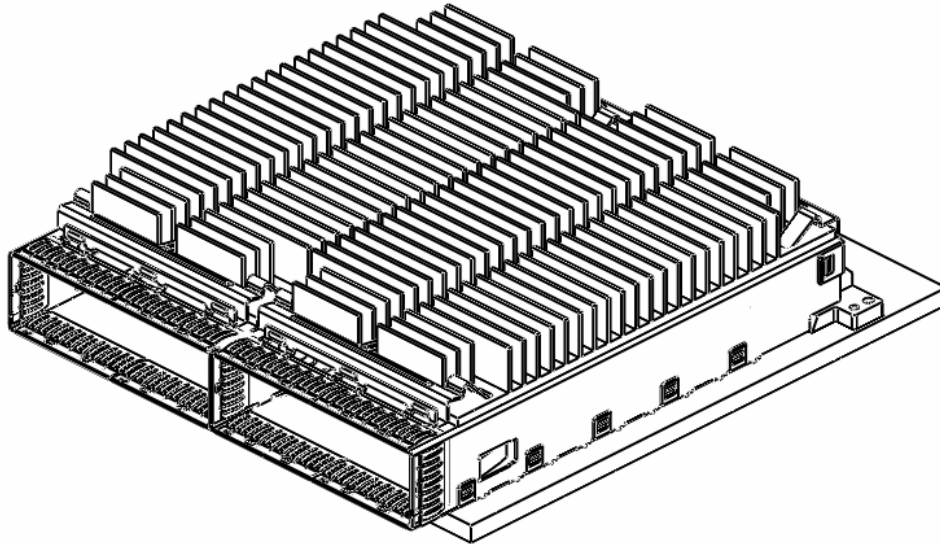

Note

All numerical values are in metric units. Dimensions are in millimeters. Unless otherwise specified, dimensions have a tolerance of ± 0.30 mm and angles have a tolerance of $\pm 2^\circ$. Figures and illustrations are for identification only and are not drawn to scale.

1. INTRODUCTION

This specification covers the requirement for application of CFP MSA requirement (The home of the CFP Multi Source Agreement). CFP2 connector assembly is 0.60mm pitch, right angle surface mount connector. A Cage that provides a positive stop for the CFP2 transceiver and EMI isolation for the connector assembly. Threaded holes in the connector cover hold the CFP2 transceiver in place once installed. The optional heat sink will help dissipate heat in high performance application.

OPTICAL MODULE & CONNECTOR ASSEMBLY EXPLOITED VIEW

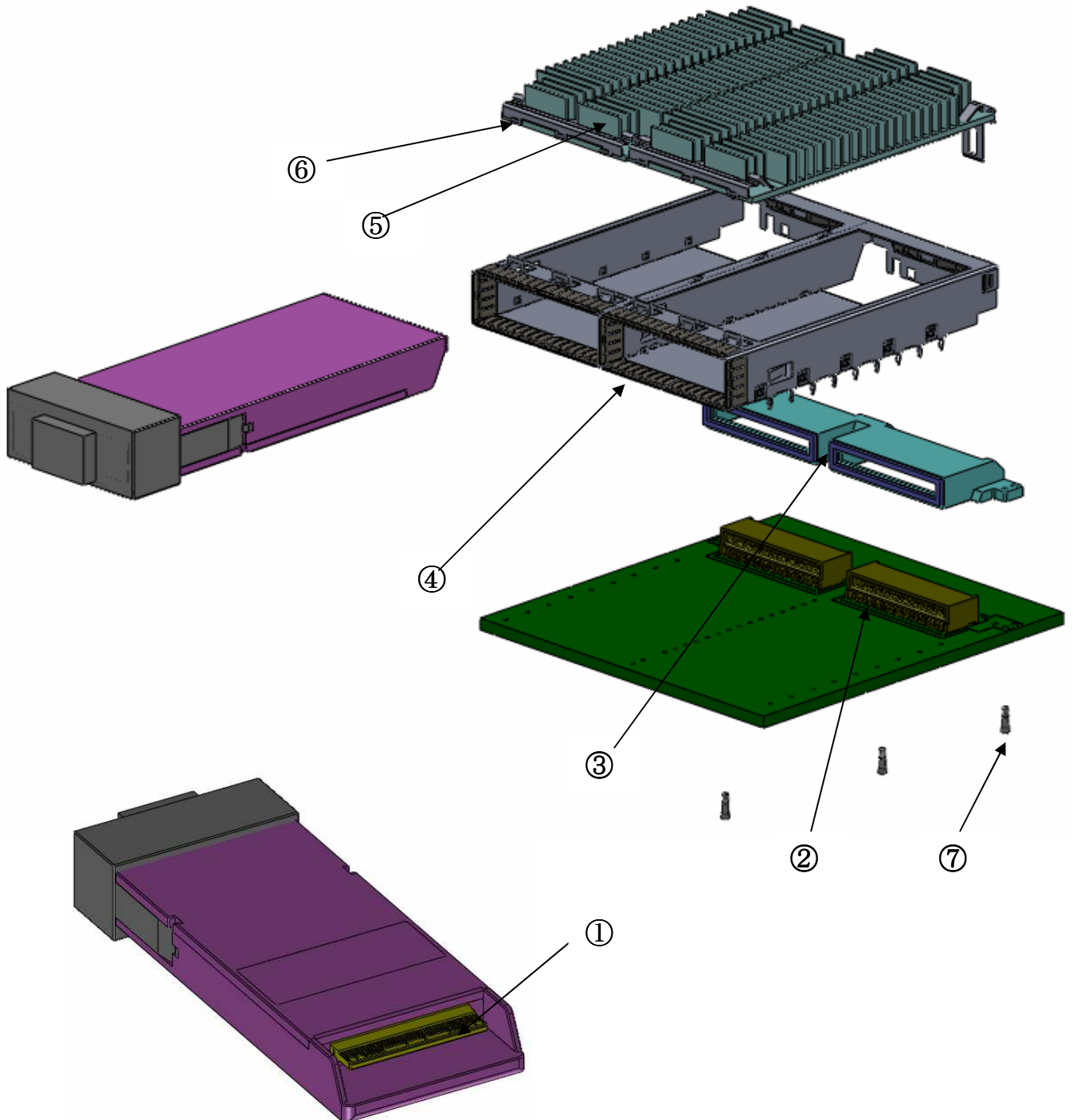

Standard components

OPTICAL MODULE & KEY COMPONENTS

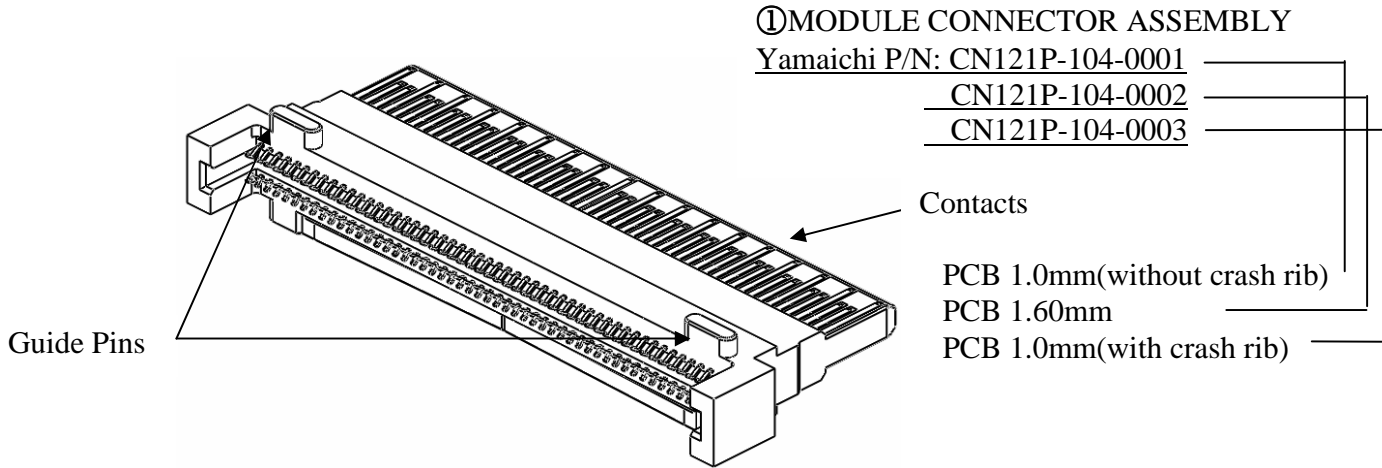

OPTICAL MODULE & KEY COMPONENTS

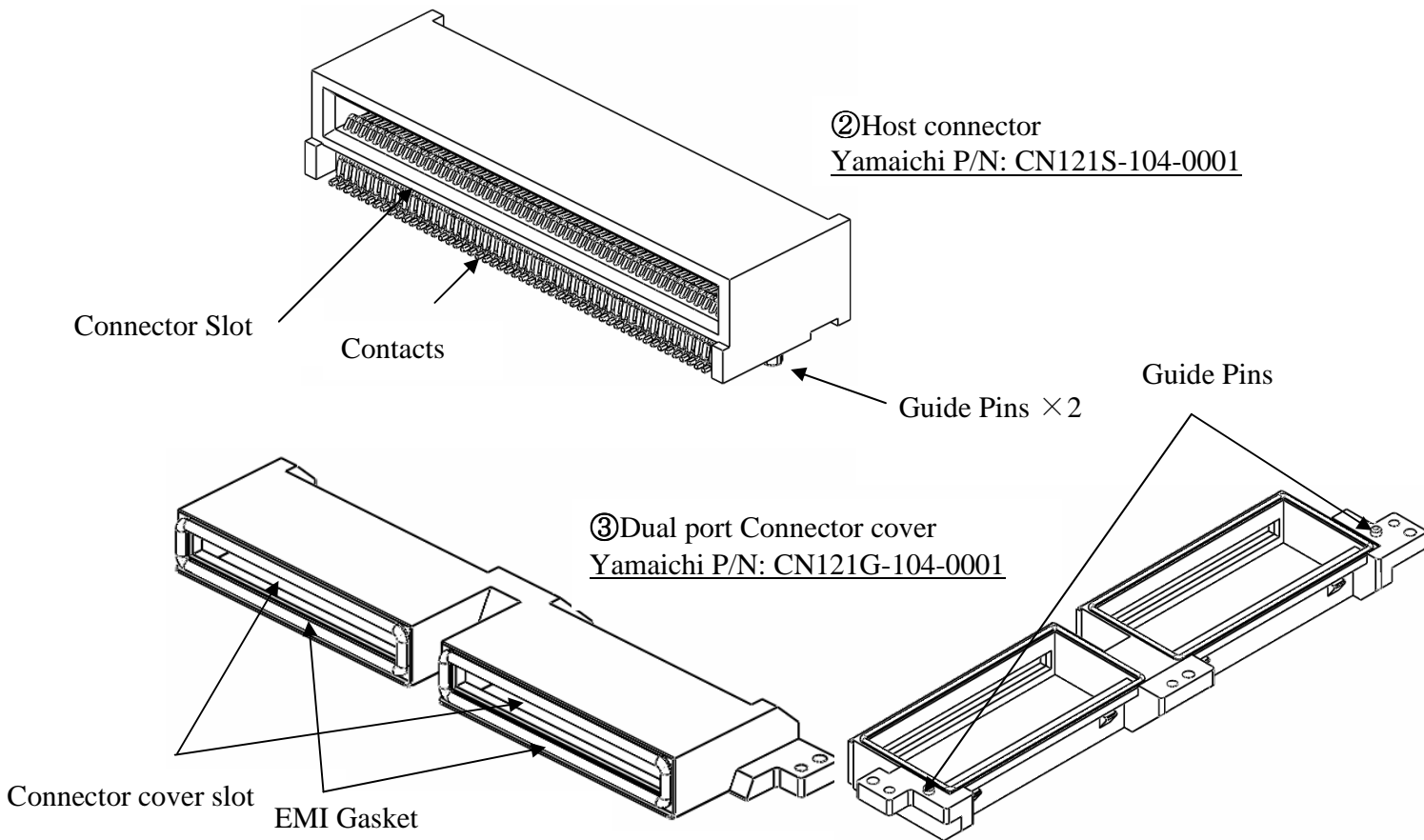

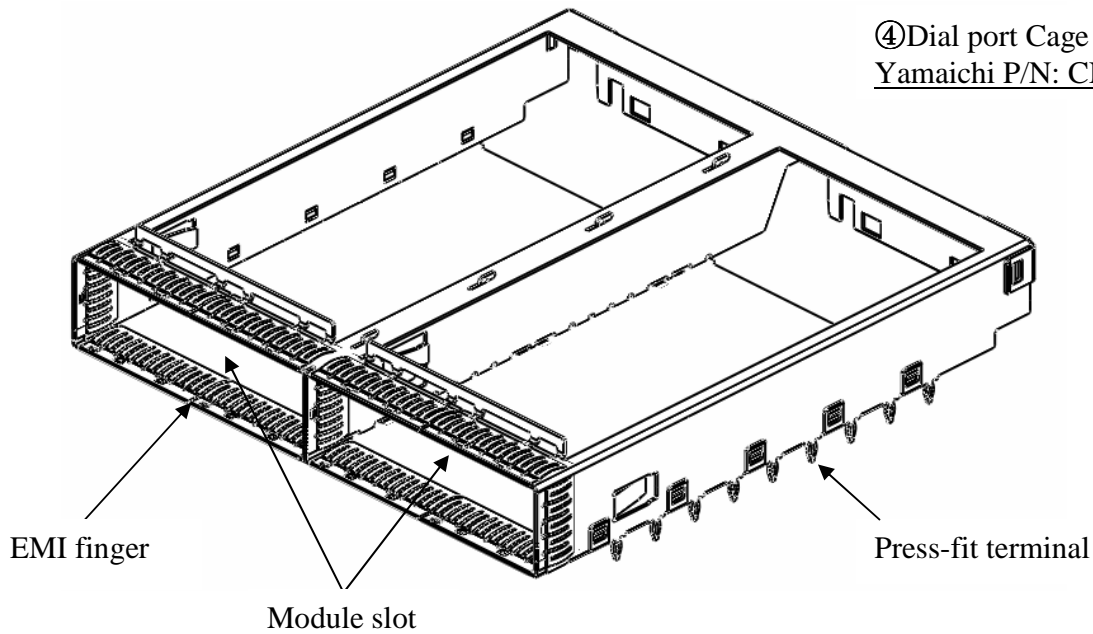

④ Dial port Cage
Yamaichi P/N: CN121C-104-0001

⑤ Aluminum Heat sink (Side to Side)
Yamaichi P/N: CN121F-104-0001

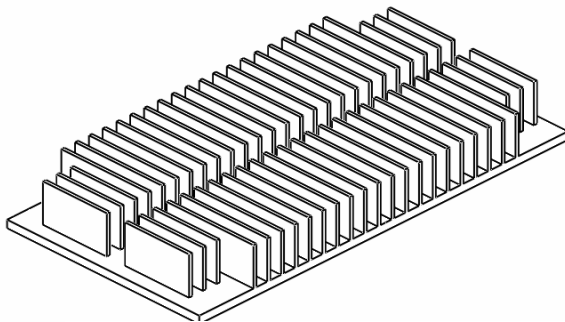

⑤ Low profile Heat sink (Side to Side)
Yamaichi P/N: CN121F104-YEU01

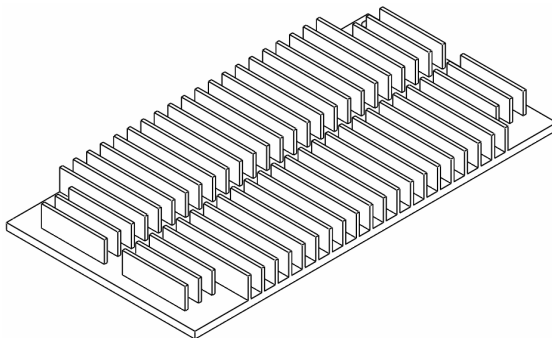

⑤ Aluminum Heat sink (Front to back)
Yamaichi P/N: CN121F-104-0003

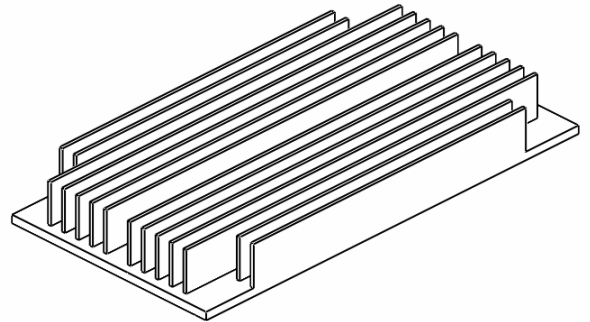

⑤ Copper Heat sink (Side to Side)
Yamaichi P/N: CN121F-104-0004-YEU

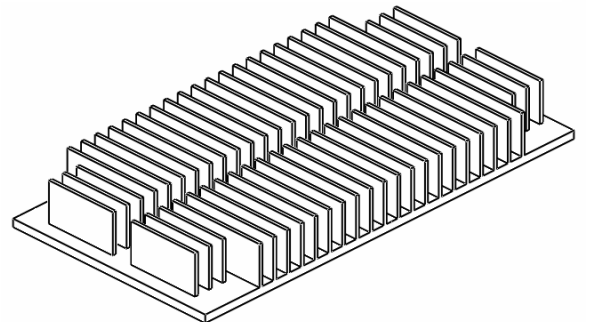

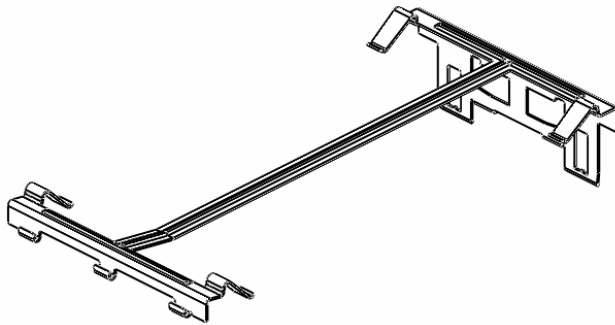

⑥ Heat sink clip
Yamaichi P/N: CN121M104-0001

⑦ Standard screw
Yamaichi P/N: CN121-03#SC

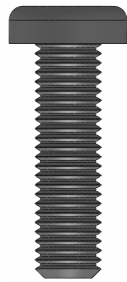

⑦ Long screw (for Belly to Belly configuration)
Yamaichi P/N: CN121-01#SC



Optional Mechanical set

Mechanical kit
Yamaichi P/N: CN121A-104-0004

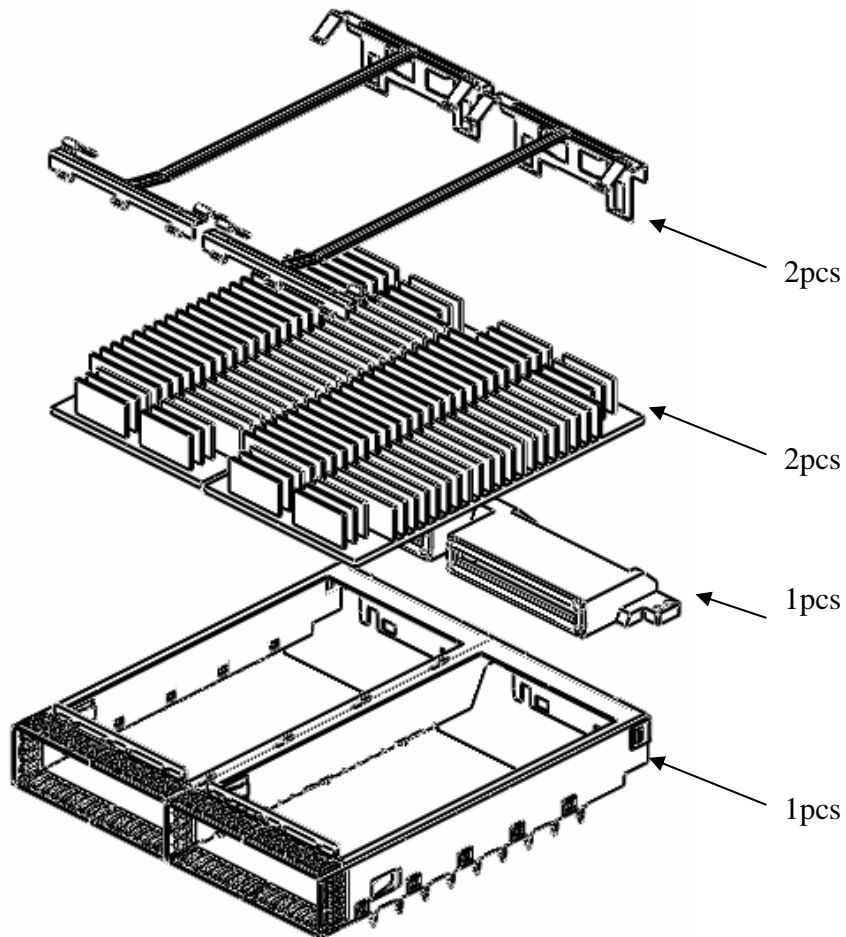

Optional Single port configuration

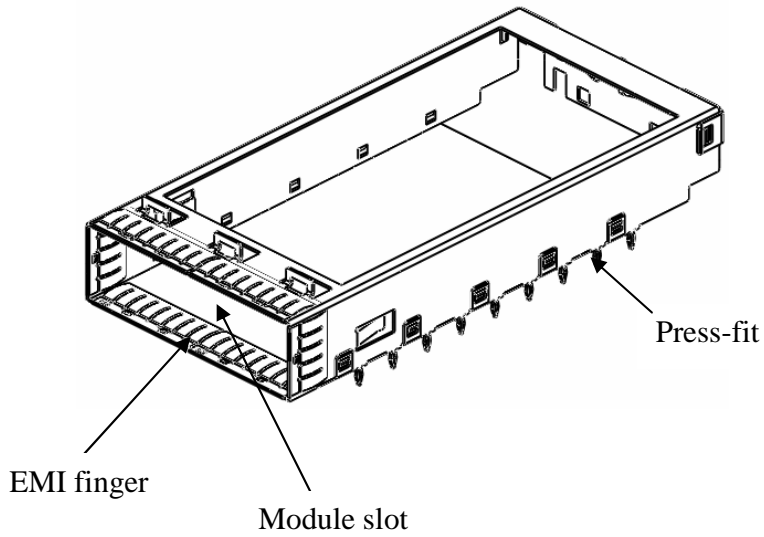

Single port cage
Yamaichi P/N: CN121C-104-0002

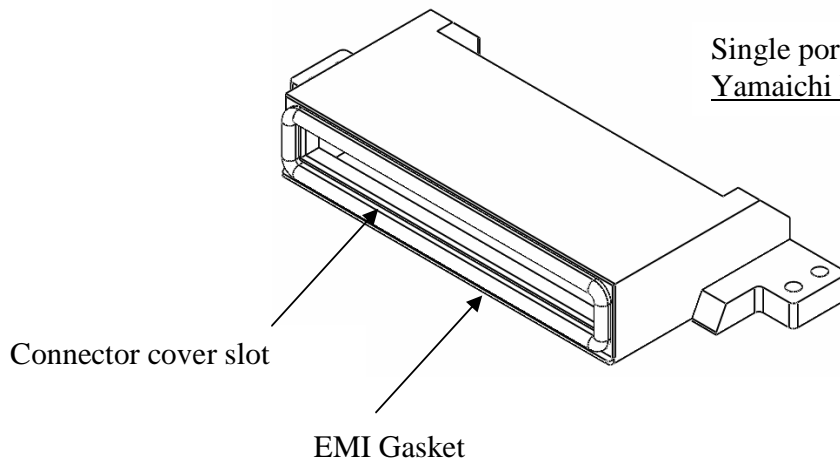

Single port connector cover
Yamaichi P/N: CN121G-104-0002

Optional Mechanical set configuration (Single port)

Single port kit
Yamaichi P/N: CN121A-104-0003

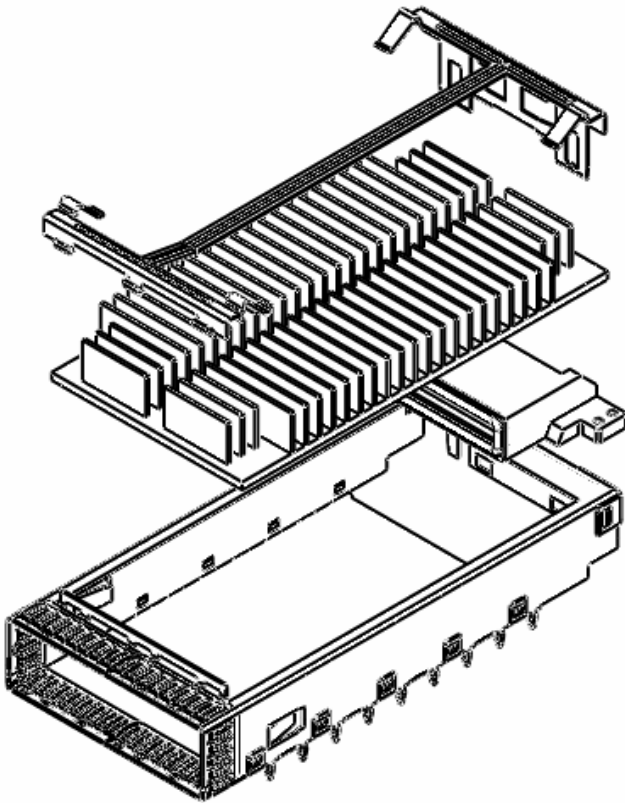

Single port kit
Yamaichi P/N: CN121A-104-0006

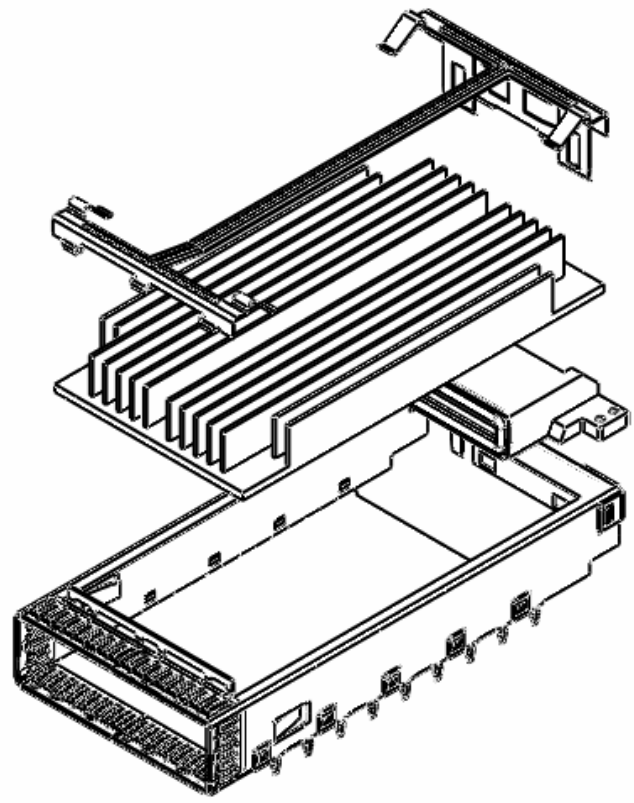

2. REFERENCE MATERIAL

2.1 Revision Summary

Revisions to this application specification include.
 We will revise this application specification if there is additional information on this without notice.

2.2 Customer Assistance

Reference product base part number are following table. Use of these numbers will identify the product line and help you to obtain more information. Such information can be obtained through a local Yamaichi Electronics office or representative. (<http://www.yeu.com/>).

Yamaichi P/N	Description
CN121S-104-0001	Host connector
CN121P-104-0001	plug connector
CN121P-104-0002	
CN121P-104-0003	
CN121G-104-0001	Dual port connector cover
CN121G-104-0002	Single port connector cover
CN121C-104-0001	Dual port cage
CN121C-104-0002	Single port cage
CN121F-104-0001	Side to Side heat sink(aluminum)
CN121F-104-YEU01	Low profile Side to Side heat sink(aluminum)
CN121F-104-0004-YEU	Side to Side heat sink(copper)
CN121F-104-0003	Front to Back heat sink(aluminum)
CN121M-104-0001	Heat sink clip
CN121A-104-0004	Dual port Mechanical set (Side to Side heat sink)
CN121A-104-0003	Single port Mechanical set (Side to Side heat sink)
CN121A-104-0006	Single port Mechanical set (Front to Back heat sink)

2.3 Specification

Product specification CN121x-104-xxxx(F114177-001) provides product performance , test information and PC board layout information.

2.4 Design baseline

CFP2 design baseline are located on the CFP MSA website
 (<http://cfp-msa.org/documents.html>)

2.5 Hard ware specification

CFP2 Hardware specification are located on the CFP MSA website

(<http://cfp-msa.org/documents.html>)

3. REQUIREMENTS

3.1 Safety and packaging

Do not stack product component containers so high that the containers buckle or deform. Please refer to packaging specification listed following table.

Packing Specification

Yamaichi P/N	Description
CN121S-104-0001	Host connector
CN121P-104-0001	plug connector
CN121P-104-0002	
CN121P-104-0003	
CN121G-104-0001	Dual port connector cover
CN121G-104-0001	Single port connector cover
CN121C-104-0001	Dual port cage
CN121C-104-0002	Single port cage
CN121F-104-0001	Side to Side heat sink
CN121F-104-0003	Front to Back heat sink
CN121M-104-0001	Heat sink clip
CN121A-104-0004	Dual port Mechanical set (Side to Side heat sink)
CN121A-104-0003	Single port Mechanical set (Side to Side heat sink)
CN121A-104-0006	Single port Mechanical set (Front to Back heat sink)

3.2 Shelf Life

The products should be used on a first in, first out basis to avoid storage contamination that could adversely affect performance.

3.3 Connector operating temperature range

The connectors are designed to operate in a temperature range -55 to 85°C.

3.4. HANDLING AND INSTALLATION

When handling surface mount connectors, pay careful attention to the following points.

3.4-1

To retain terminal flatness, protect the damage before mounting onto PCB, it is recommended that host connector is mounted using automated machinery. Be especially careful when mounting host connector by hand.

3.4-2

To assure the sufficient retention strength, do not insert the plug connector in to the host connector slot before mount the host connector on to PCB. Be sure that no external forces are applied to the terminal or the contacts.

3.4-3

Performance of the products used without connector cover can not be guaranteed.

3.4-4

Connectors should be handled only by housing to avoid terminal deformation, contamination and damage.

3.5 MATERIAL

The host connector and plug housing are made of LCP, US94-V0. The contacts are made of copper alloy plated with gold over nickel. Cage and heat sink clip are made of stainless, heat sink is made of zinc and heat sink is aluminum or copper.

3.6 PC board Layout

All holes and circuit pads must be precisely located on the pc board to ensure proper placement and optimum performance of the connector, cover and cage. Recommended circuit pattern, keep out area, dimensions, and tolerances for pc board are provided in the specification drawings.

(Refer to CN121x-104-xxxx:SPEC)

4. Soldering

The connector must be soldered using non-focused infrared (IR) or equivalent soldering technique. When mounting to both side of the host PC board, the surface tension of the solder when it is in the liquids state will hold the connector on the PB board. Reflow temperature and time may vary depending on the size of the host PC board and placement of other components. Please confirm reflow condition beforehand.

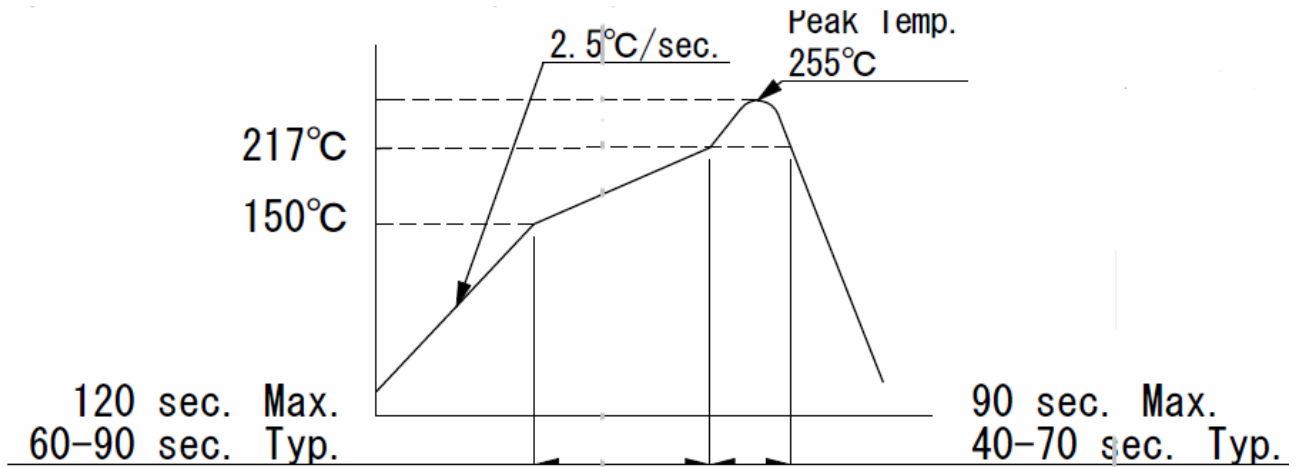

Plug connector Assembly instructions

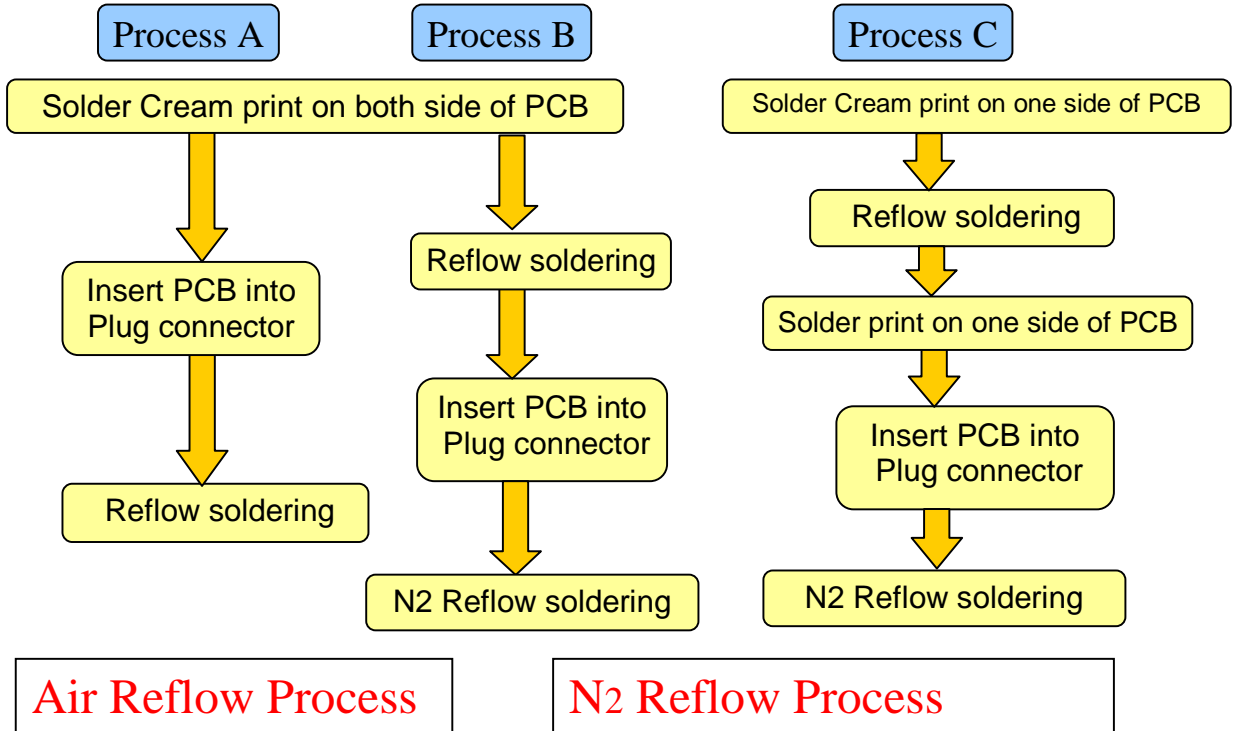

Process A: One time Reflow soldering

1-3. Reflow soldering

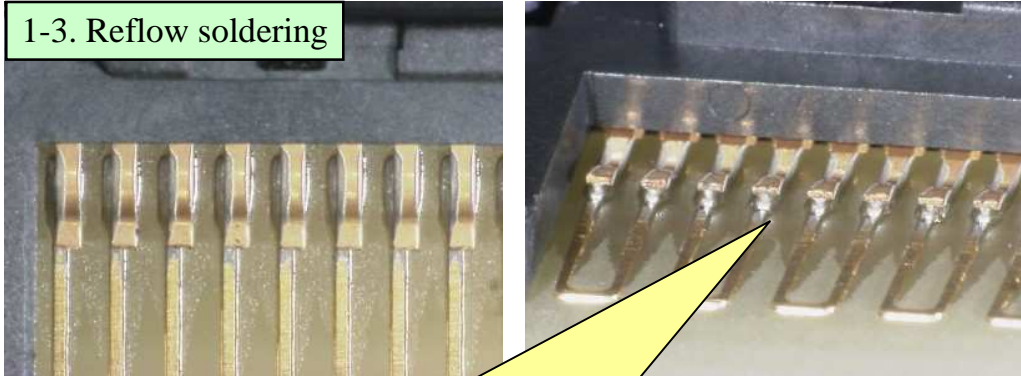

Solder is gathered to the terminal area and creates a fillet by reflow soldering.

Process B: 2 times Reflow soldering

1. Print solder

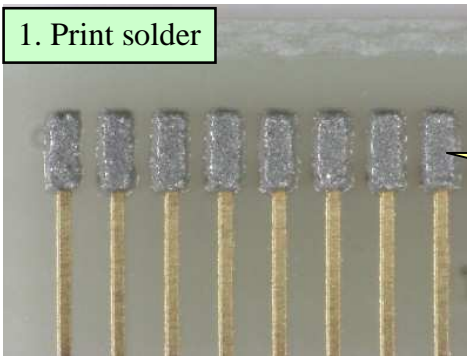

Print solder past on the both side of PCB.

2-2. First reflow soldering

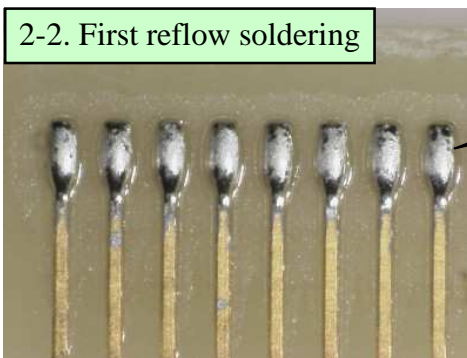

To melt solder paste once by reflow and cool it down to harden.

Process B: 2 times Reflow soldering

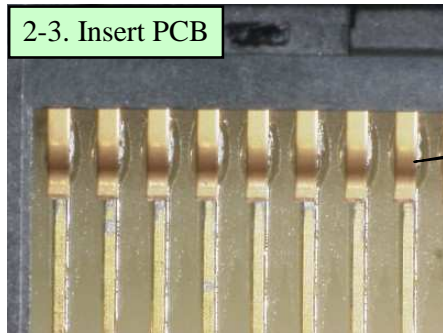

Insert PCB

Solder is gathered to terminal area and create its filet by 2nd N2 reflow soldering.

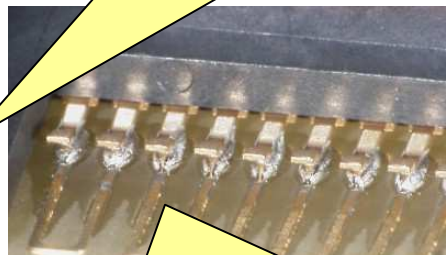
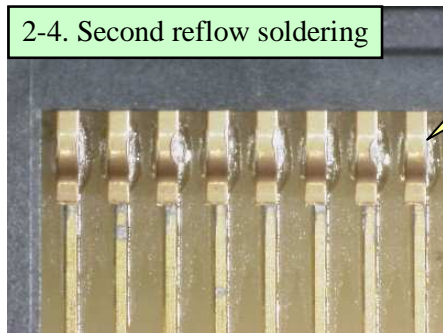

Recommend to use N2 reflow process to create favorable filet.

Connector assembly procedure instruction

Host connector

1-1. Solder print on the PCB and place the host connector



1-2. Reflow soldering

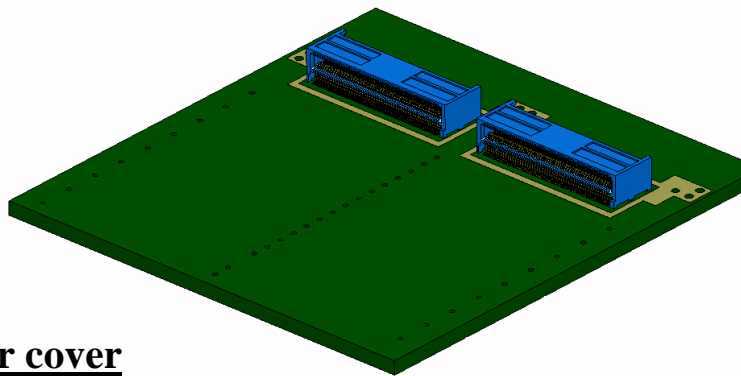

Connector displayed on page 3, must be positioned so the guide pins are aligned with the guide pin holes on the host PC board. Care must be taken to avoid damage to the terminals and connector.

Connector cover

Yamaichi provide connector cover with M1.4 × 3 screws.

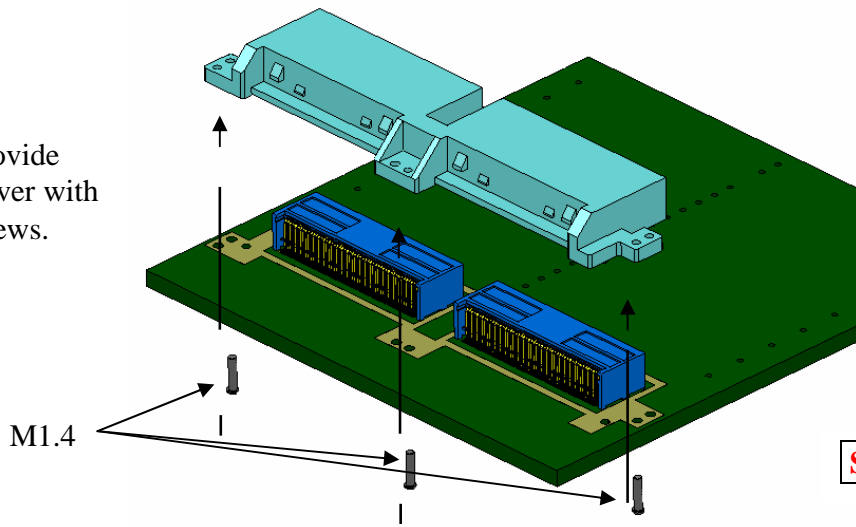

Connector cover displayed on page 3, must be positioned so the guide pins are aligned with the guide pin holes on the host PC board. Care must be taken to avoid damage to the connector cover.

Screw Torque : 0.10N · m

1-1. Put the connector cover on the PCB

1-2. Screw the connector cover using M1.4 screws from opposite side in three locations.

Screw instruction

Single connector cover with side to side configuration

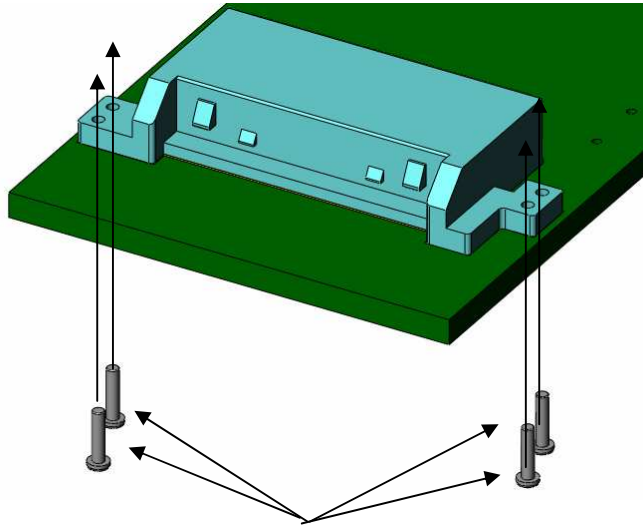

Standard screws \times 4.
PN : CN121-03-SC

Dual connector cover with side to side configuration

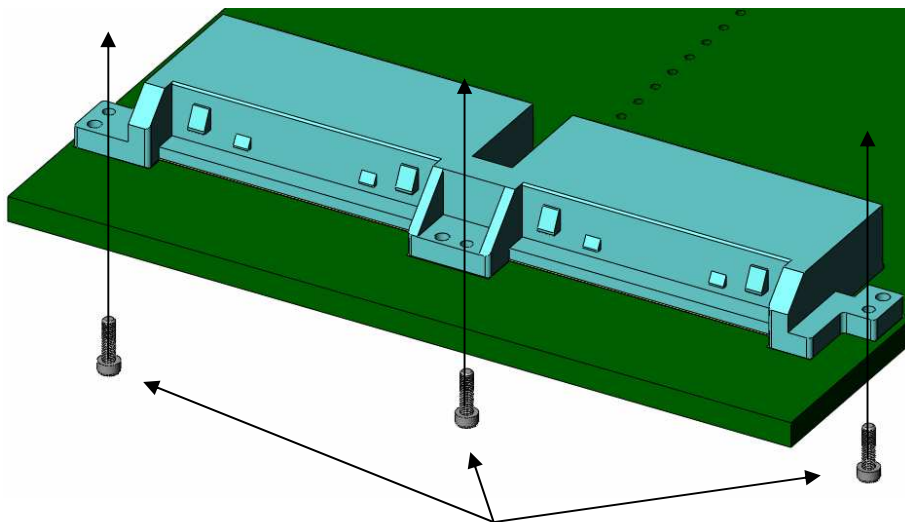

Standard screws \times 3
PN : CN121-03-SC

Single connector cover with Belly to Belly configuration

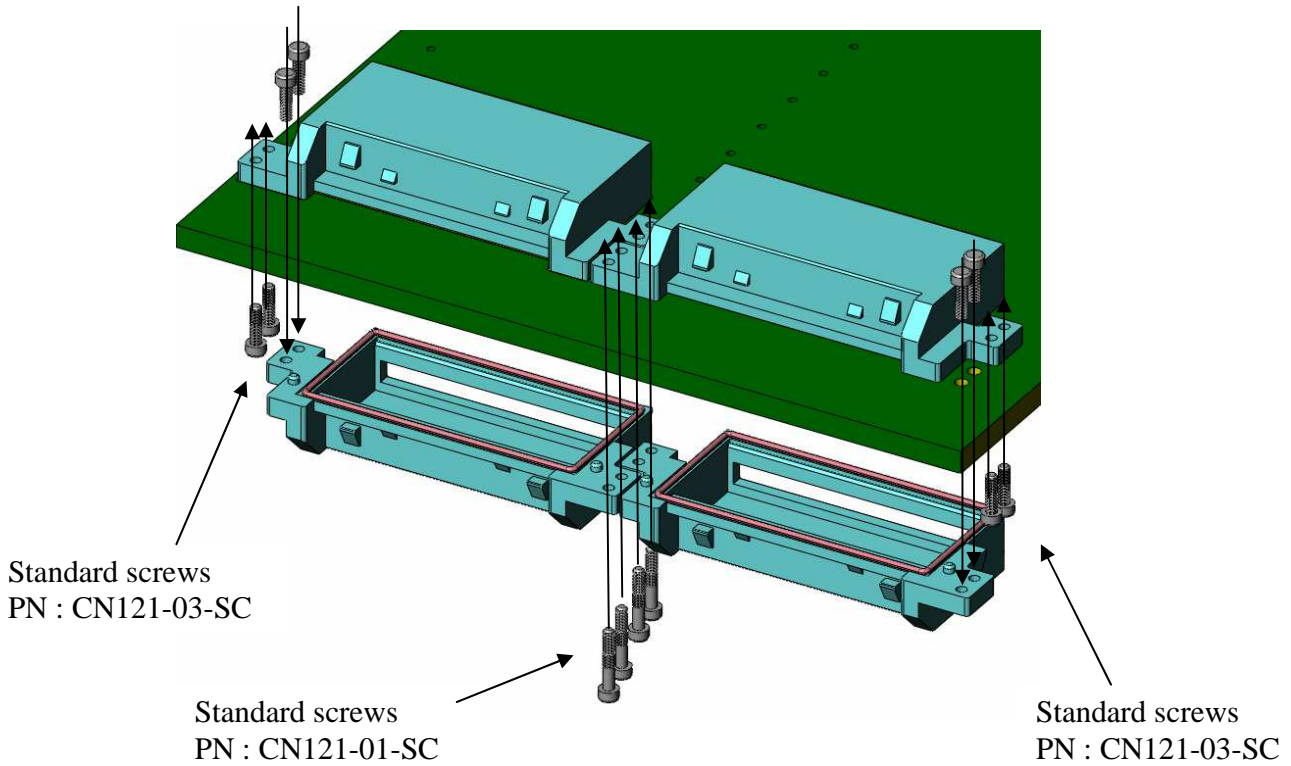

Dual connector cover with Belly to Belly configuration

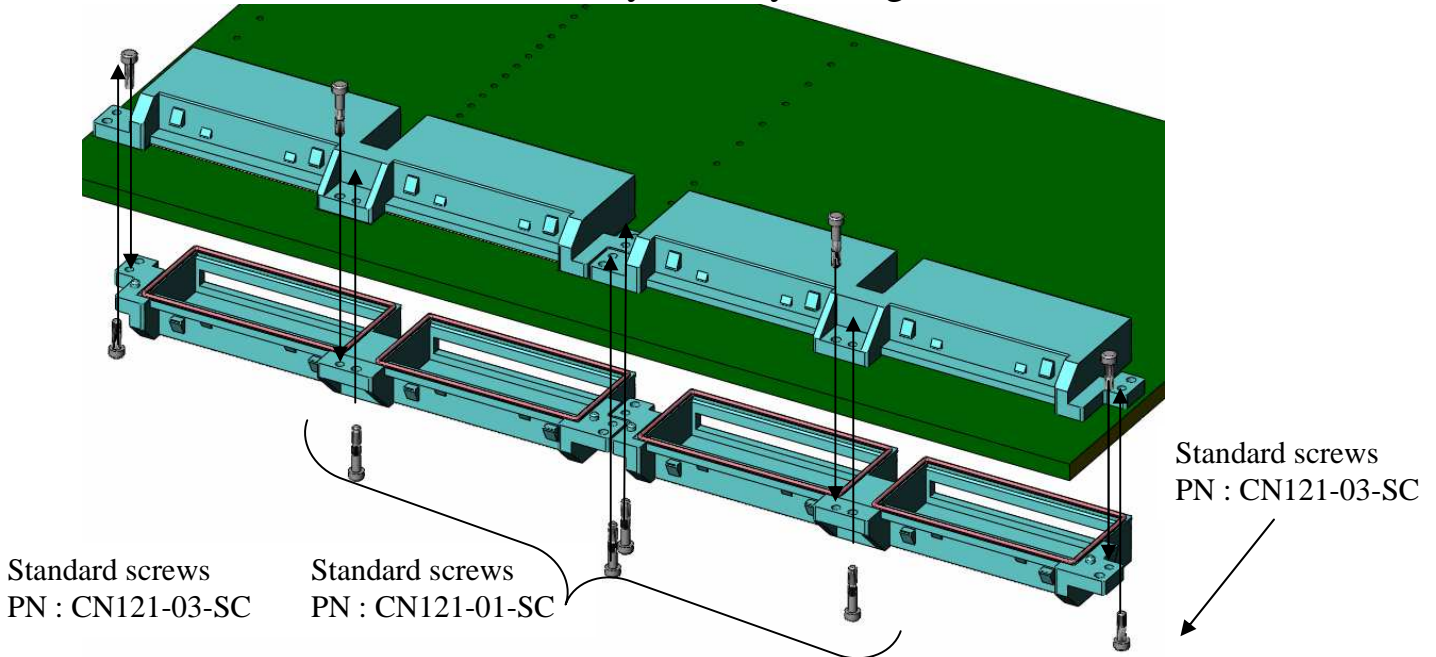

Cage

STEP1 : Press fit the Cage to the PCB using jig tool fixture

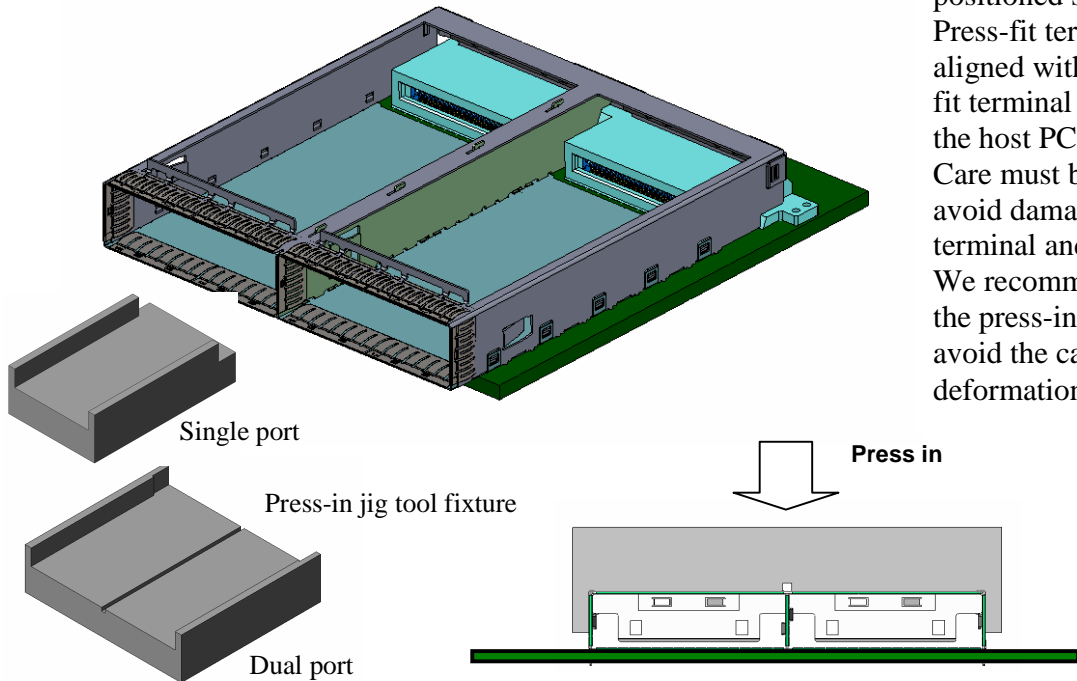

Cage displayed on page 4, must be positioned so the Press-fit terminals are aligned with the press-fit terminal holes on the host PC board. Care must be taken to avoid damage to the terminal and cage. We recommend to use the press-in jig to avoid the cage deformation.

Note: Press-in jig tool fixture design guidance can be provided. Please contact your Yamaichi representative.

STEP 2 : Place the heat sink on the cage

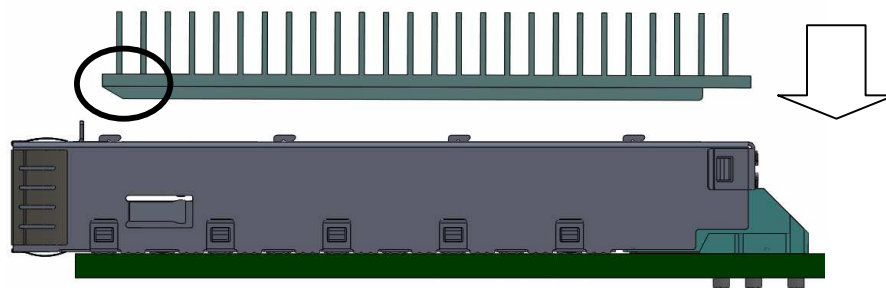

Note: Heat sink has insertion direction, chamfer position is front side to insert the Module smoothly.

STEP 3 : Install heat sink clip on the cage

Put the edge of clip on the front side first to engage the three tangs and as a next step, press the rear side of clip to engage two tangs.

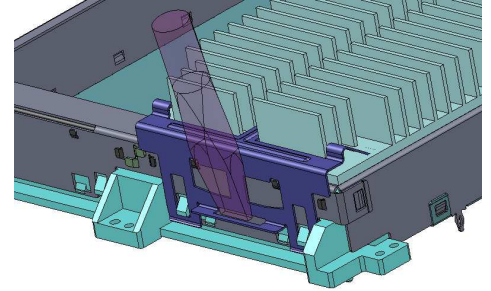
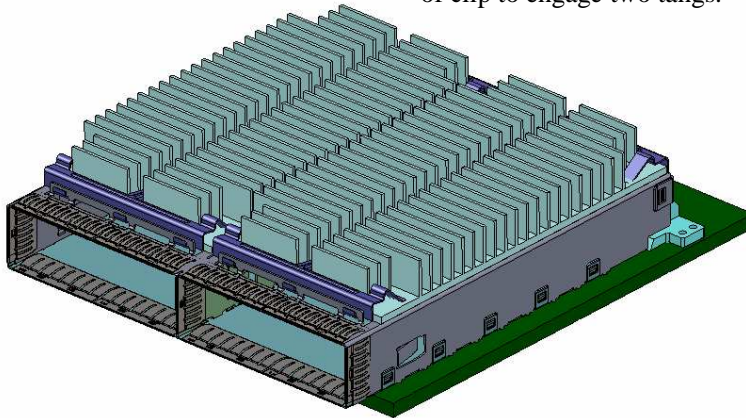

When you release clip,
please use tool
(ex. Screw Driver)

Plug connector

Projections: Alignment and Strain Relief for mating of connector

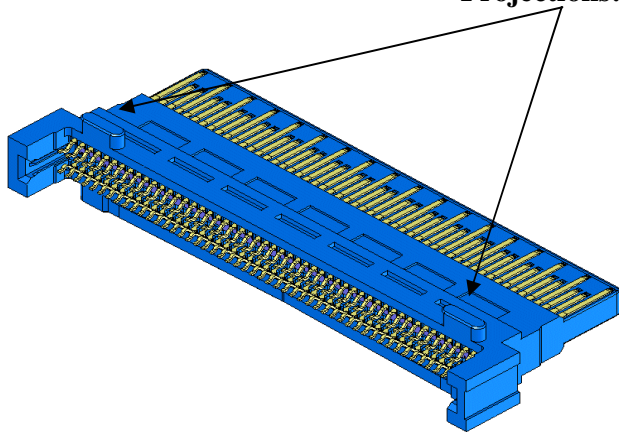

Bar:
This has spring function to place in position.

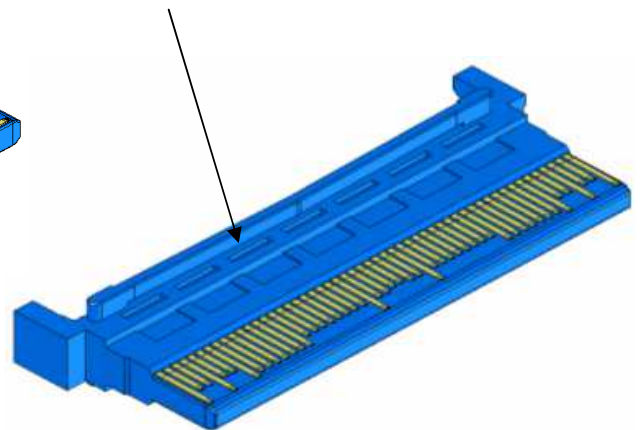

Plug connector assembly

Projections put into Slot of Module Top Case

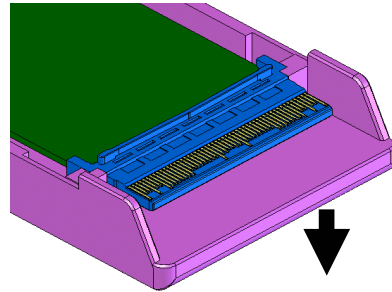
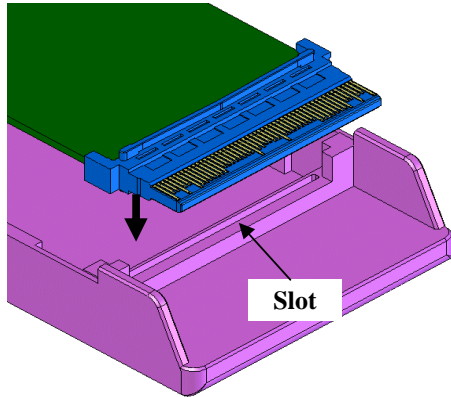

Spring put into Slot of Module Bottom Case

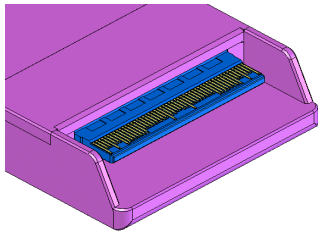
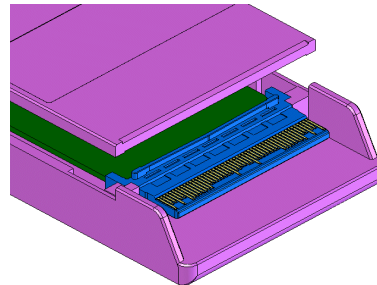

PANEL

The panel must provide a cut out that allow proper position for transceiver. The panel and host PC board must be positioned in relation to each other to avoid interference with the insertion and extraction of the transceiver. This relationship must confirm to dimensions given following figure.

For Dual port configuration panel reference design

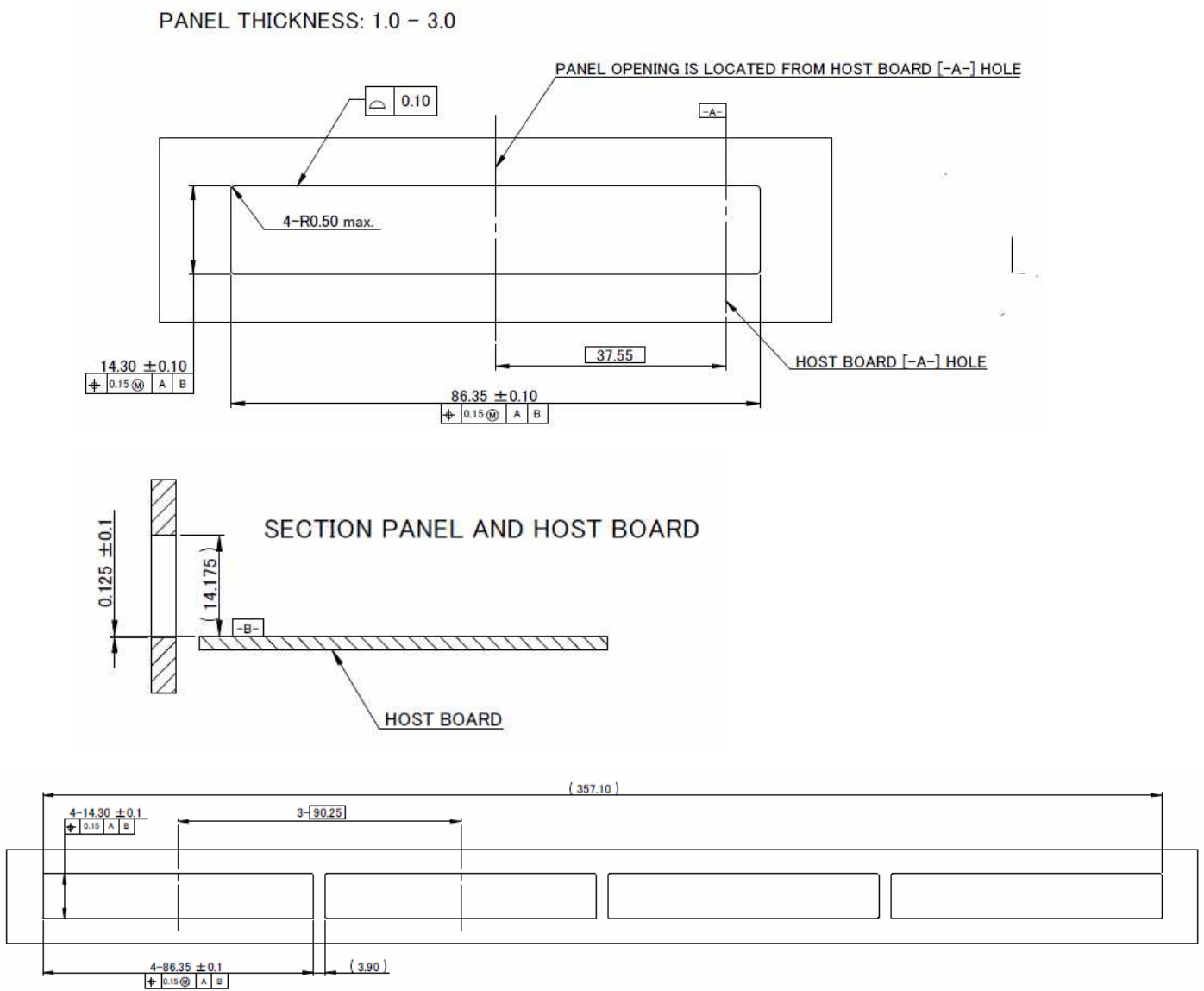

Relationship with Panel and PB

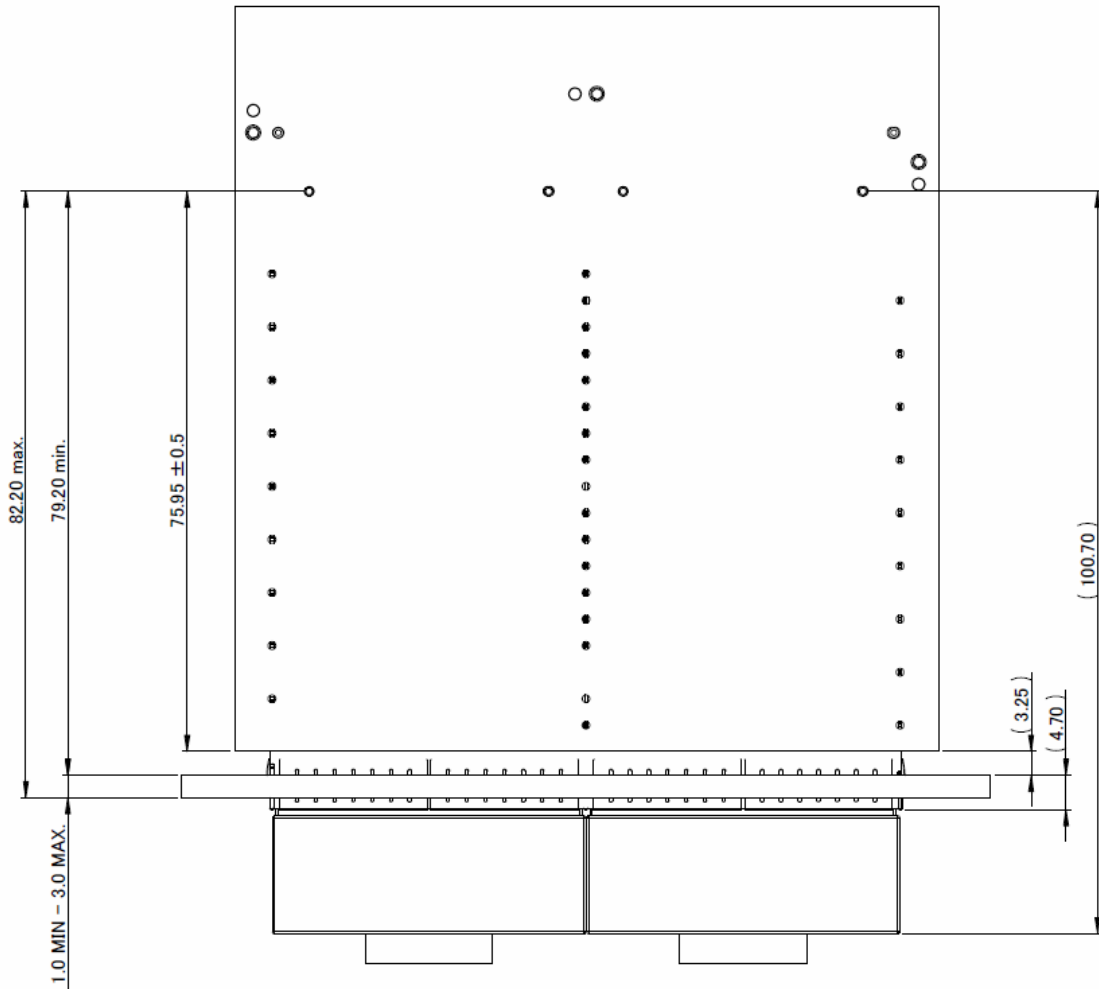

For single port configuration panel reference design

PANEL THICKNESS : 1.0-3.0

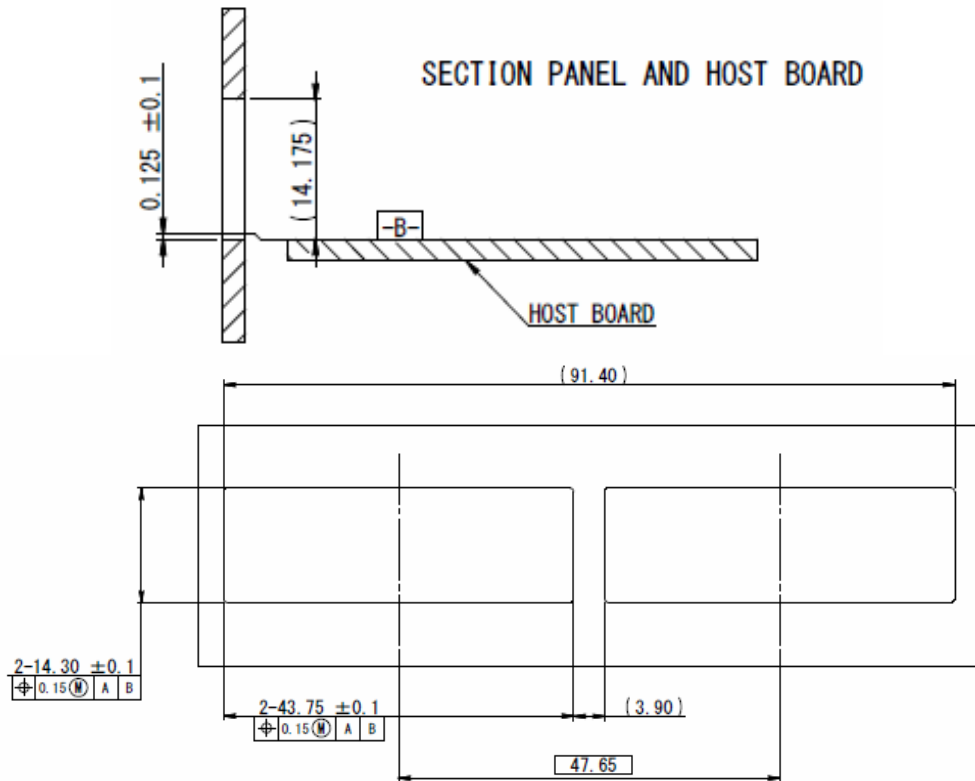
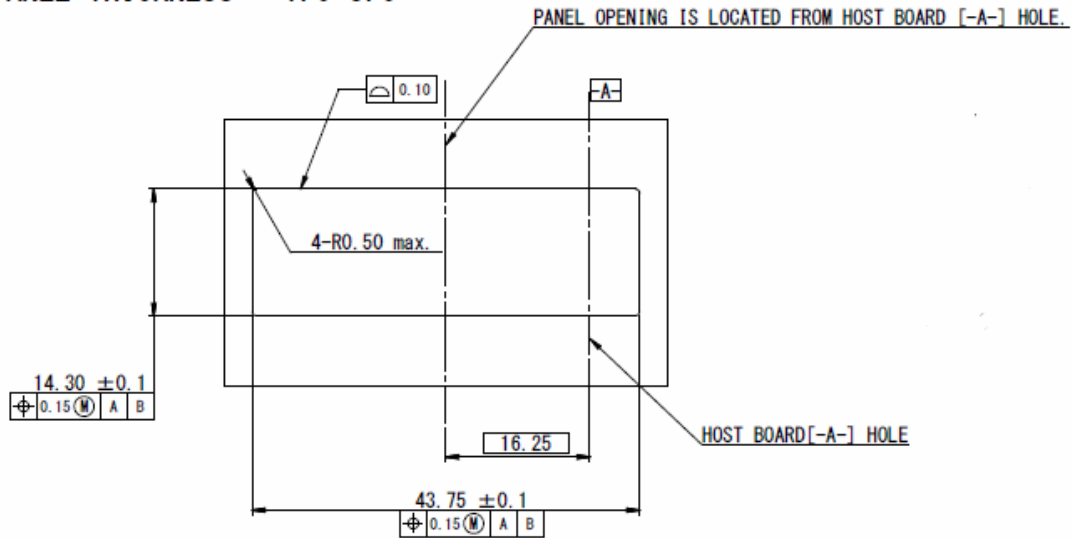

SI break out board

Yamaichi local office has SI break out board to evaluate the SI performance. Such information can be obtained through a local Yamaichi Electronics office or your representative.(<http://www.yeu.com/>)

Pin assignment

These pin assignment is not complied to MSA, these are for connector performance measurement purpose.



PN: CN121-PCB-02xx
(Measure with 2.4mm connector)

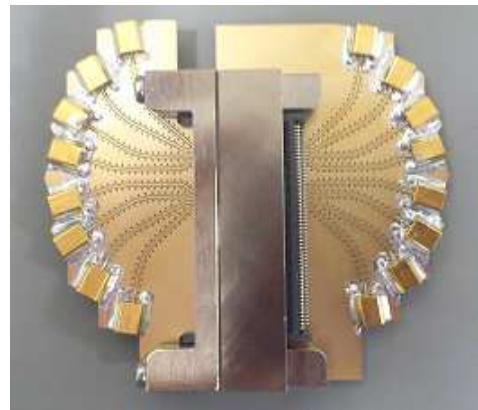

PN:CN:121-PCB
(Measure with GPPO connector)

Accessory product
Dust Cap



Yamaichi P/N : CN121D-104-0002

This Dust cap has EMI shielding function

Dummy Module



Yamaichi P/N : CN121D-104-0001

Dummy Module is used for heavy heat sink user (This product also has EMI shielding function.)

X-ON Electronics

Largest Supplier of Electrical and Electronic Components

Click to view similar products for [I/O Connectors](#) category:

Click to view products by [Yamaichi](#) manufacturer:

Other Similar products are found below :

[571763P](#) [58098-0628](#) [72.250.1628.2](#) [72.250.2428.2](#) [74720-0505](#) [76.350.0729.0](#) [76871-1403](#) [FCN-244F080-G/1](#) [FCN-260A9920](#) [MP-5T180MUNNA-005](#) [PCR-E36PM](#) [PCS-XE26MA+](#) [G38A71314B](#) [DX40-50P\(55\)](#) [1571250010](#) [157-22500-3](#) [MS3471L14-19P L/C](#) [91-569786-35H](#) [172501-4002](#) [172501-6002](#) [FCN-260C008-A/L0](#) [FCN-260C024-AL0](#) [FCN-261Z008](#) [2000314-1](#) [200331-1](#) [PCR-E36FC+](#) [PCS-E28FS+](#) [PCS-XE26SLFD+](#) [PCS-XE26SLFDT+](#) [G730VID08BDC24](#) [U90B2054081210](#) [UE86K842720321](#) [38113800006](#)
[DP3AR020WQ1R200](#) [Z4.102.0680.0](#) [500-1040](#) [500-1052](#) [500-1054](#) [ZP-4008-66L](#) [0709821002](#) [10-565995-597N](#) [DX40-20P\(55\)](#) [5554841-1](#)
[MS3474W18-8P-LC*](#) [U90B3054061110](#) [U65-E04-4020](#) [ZPF000000000097891](#) [557-262M2-06C](#) [747360449](#) [10099439-003C-TRLF](#)