

Dual PNP Small Signal Transistor

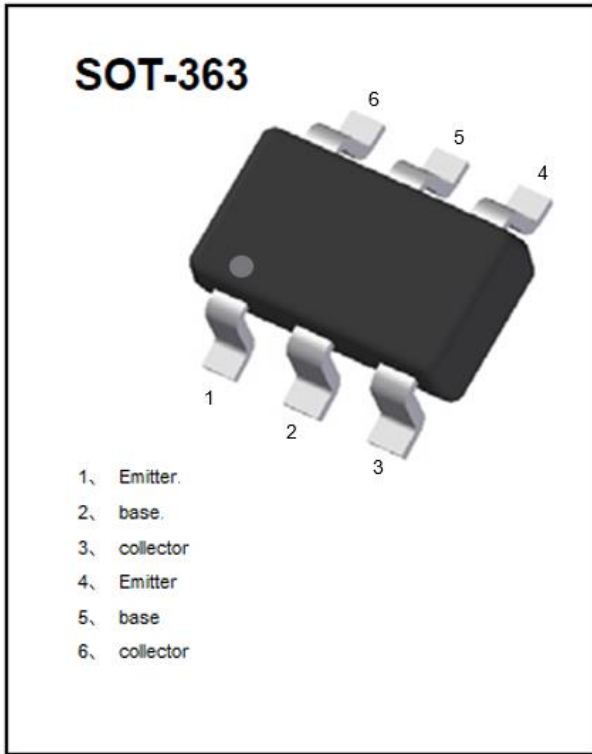

Features

- Epoxy meets UL-94 V-0 flammability rating
- Surface mount package ideally Suited for Automatic Insertion
- PNP

Mechanical Data

- **Package:** SOT-363
- **Terminals:** Tin plated leads, solderable per J-STD-002 and JESD22-B102
- **Marking:** 5Ft

■Equivalent circuit

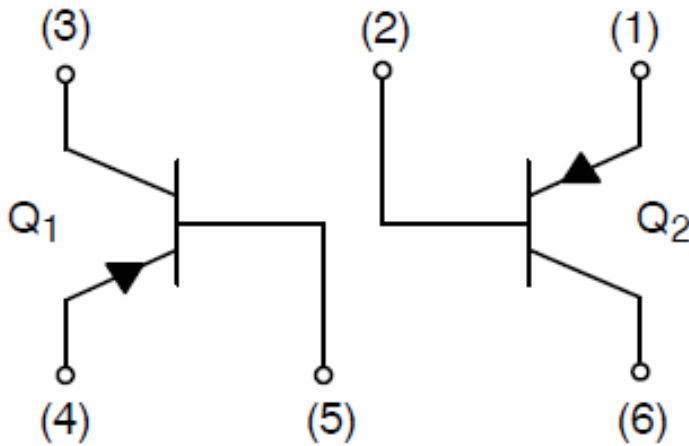



BC856S

■Maximum Ratings (Ta=25°C Unless otherwise specified)

Item	Symbol	Unit	Conditions	Value
Collector-Base Voltage	VCBO	V	IC=-10μA,IE=0	-80
Collector-Emitter Voltage	VCEO	V	IC=-10mA,IB=0	-65
Emitter-Base Voltage	VEBO	V	IE=-10μA,IC=0	-5
Collector Current	IC	mA		-100
Total Device Dissipation	PC	mW		200
Junction Temperature	Tj	°C		-55 to +150
Storage Temperature	TSTG	°C		-55 to +150

■Electrical Characteristics (Ta=25°C unless otherwise specified)

Item	Symbol	Unit	Conditions	Min	TYP	Max
Collector-base breakdown voltage	V _{(BR)CBO}	V	IC=-10μA,IE=0	-80		
Collector-emitter breakdown voltage	V _{(BR)CEO}	V	IC=-10mA,IB=0	-65		
Emitter-base breakdown voltage	V _{(BR)EBO}	V	IE=-10μA,IC=0	-5		
Collector-Base cut-off current	I _{CBO}	nA	VCB=-30V,IB=0			-15
Emitter-Base cut-off current	I _{EBO}	nA	VEB=-5V,IC=0			-100
DC current gain	h _{FE}		VCE=-5V,IC=-2mA	110		
Collector-emitter saturation voltage	V _{CE(sat)}	V	IC=-10mA,IB=-0.5mA			-0.3
Collector-emitter saturation voltage	V _{CE(sat)}	V	IC=-100mA,IB=-5mA			-0.65
Base-emitter saturation voltage	V _{BE(sat)}	V	IC=-10mA,IB=-0.5mA			-0.85
Base-emitter Voltage	VBE	V	VCE=-5V,IC=-2mA	-0.6		-0.75
Transition frequency	Ft	MHz	VCE=-5V,IC=-10mA,f=100MHz	100		

■ Ordering Information (Example)

PREFERED P/N	PACKING CODE	UNIT WEIGHT(g)	MINIMUM PACKAGE(pcs)	INNER BOX QUANTITY(pcs)	OUTER CARTON QUANTITY(pcs)	DELIVERY MODE
BC856S	F2	Approximate 0.009g	3000	30000	120000	7" reel



■ Characteristics (Typical)

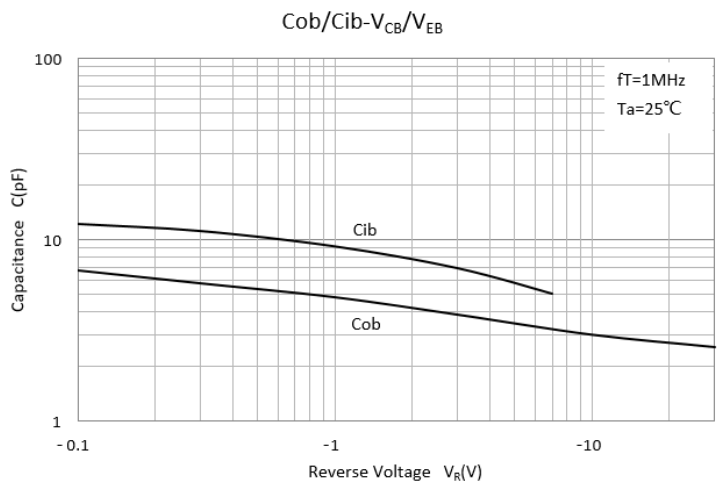
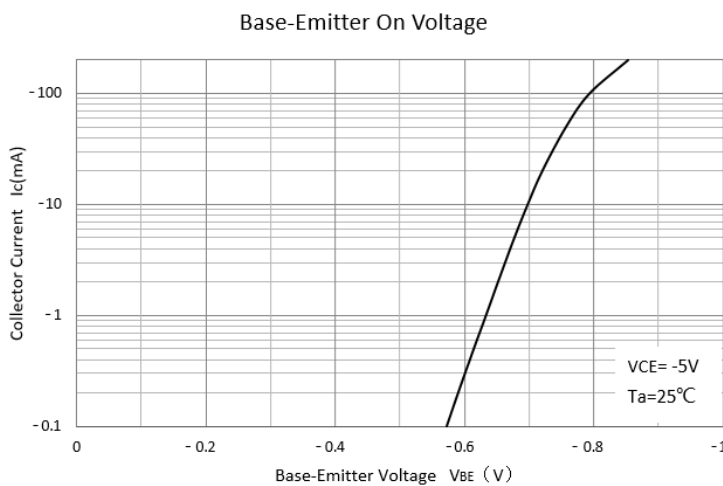
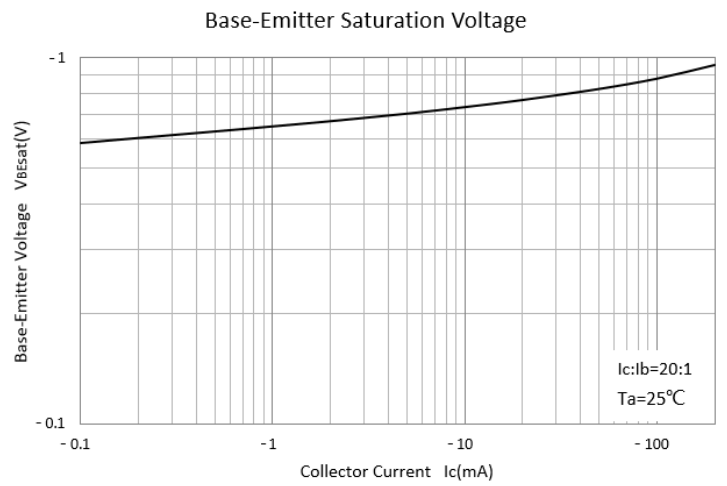
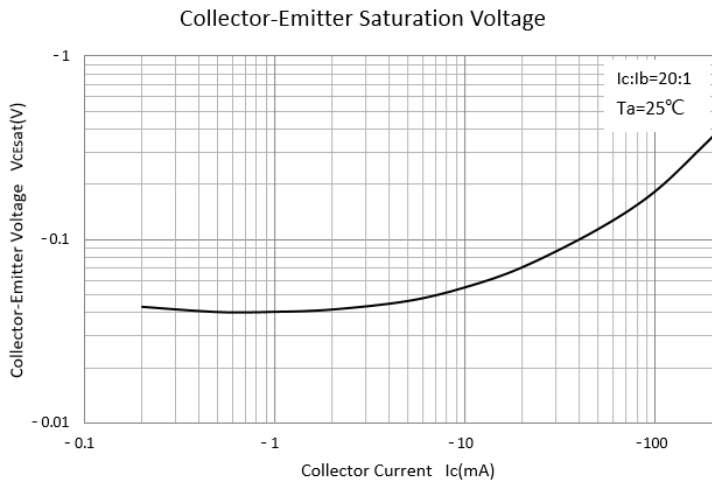
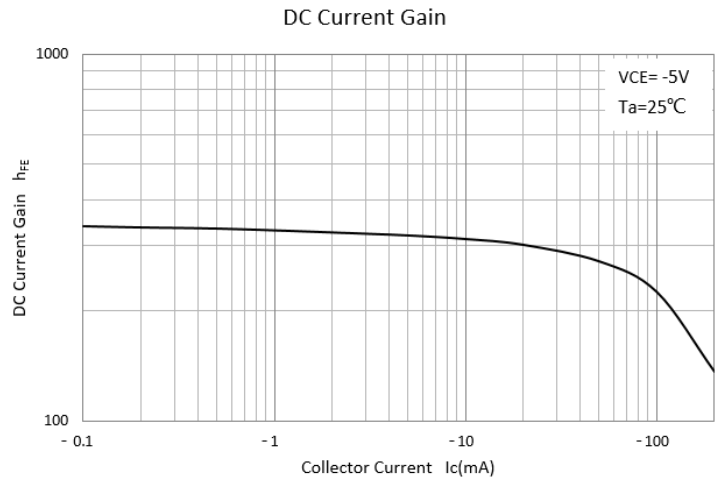
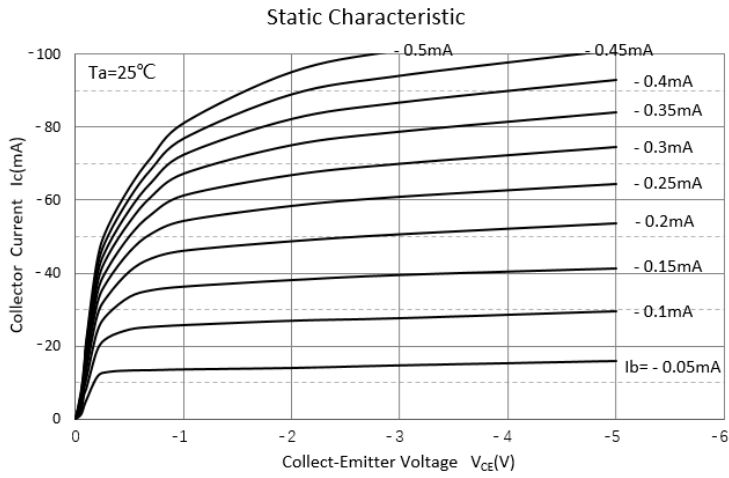



BC856S

■SOT-363 Package Outline Dimensions

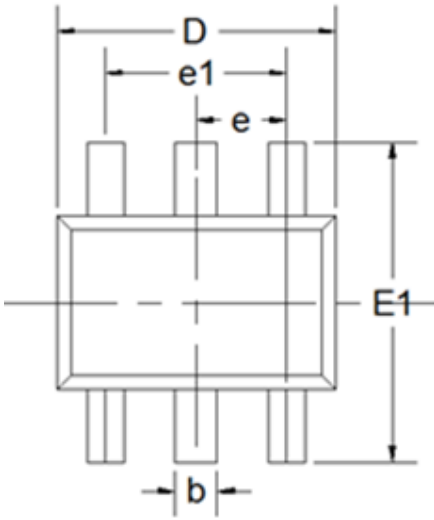

DIM	DIMENSIONS			
	INCHES		MM	
	MIN	MAX	MIN	MAX
A	0.035	0.043	0.9	1.1
A1	0	0.004	0	0.1
A2	0.035	0.039	0.9	1
b	0.006	0.014	0.15	0.35
c	0.002	0.01	0.05	0.25
D	0.071	0.087	1.8	2.2
E	0.045	0.053	1.15	1.35
E1	0.085	0.096	2.15	2.45
e	0.026Typ		0.65Typ	
e1	0.047	0.055	1.2	1.4
L	0.021Typ		0.525Typ	
L1	0.01	0.018	0.26	0.46
φ	0°	8°	0°	8°

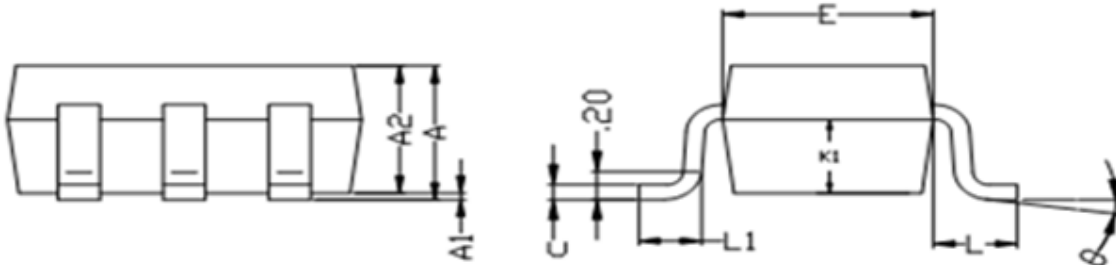

■SOT-363 Suggested Pad Layout

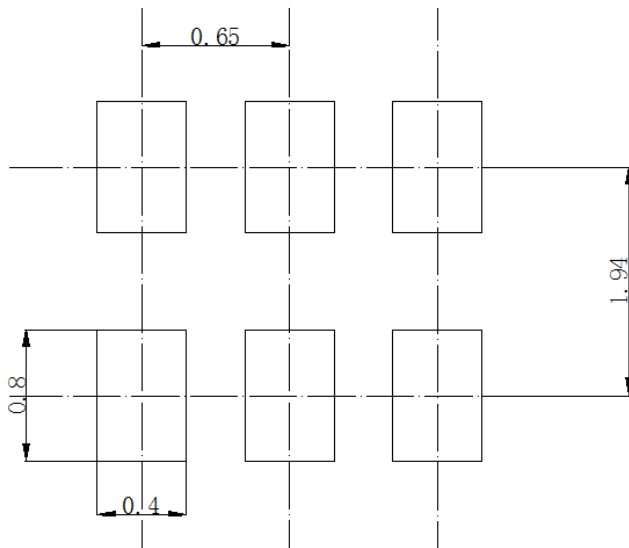

Unit: mm



Disclaimer

The information presented in this document is for reference only. Yangzhou Yangjie Electronic Technology Co., Ltd. reserves the right to make changes without notice for the specification of the products displayed herein to improve reliability, function or design or otherwise.

The product listed herein is designed to be used with ordinary electronic equipment or devices, and not designed to be used with equipment or devices which require high level of reliability and the malfunction of which would directly endanger human life (such as medical instruments, transportation equipment, aerospace machinery, nuclear-reactor controllers, fuel controllers and other safety devices), Yangjie or anyone on its behalf, assumes no responsibility or liability for any damages resulting from such improper use of sale.

This publication supersedes & replaces all information previously supplied. For additional information, please visit our website [http:// www.21yangjie.com](http://www.21yangjie.com) , or consult your nearest Yangjie's sales office for further assistance.

X-ON Electronics

Largest Supplier of Electrical and Electronic Components

Click to view similar products for [Bipolar Transistors - BJT category](#):

Click to view products by [Yangjie manufacturer](#):

Other Similar products are found below :

[BC559C](#) [MCH4017-TL-H](#) [MMBT-2369-TR](#) [BC546/116](#) [NJVMJD148T4G](#) [NTE16](#) [NTE195A](#) [IMX9T110](#) [2N4401-A](#) [2N4403](#) [2N6728](#)
[2SA1419T-TD-H](#) [2SA2126-E](#) [2SB1204S-TL-E](#) [FMC5AT148](#) [2N2369ADCSM](#) [2N2907A](#) [2N3904-NS](#) [2N5769](#) [2SC4618TLN](#) [CPH6501-](#)
[TL-E](#) [MCH4021-TL-E](#) [Jantx2N5416](#) [US6T6TR](#) [BAX18/A52R](#) [BC556/112](#) [IMZ2AT108](#) [MMST8098T146](#) [UMX21NTR](#) [MCH6102-TL-E](#)
[TTA1452B,S4X\(S](#) [2N3879](#) [NTE13](#) [NTE282](#) [NTE323](#) [NTE350](#) [NTE81](#) [JANTX2N2920L](#) [JANTX2N3735](#) [JANSR2N2222AUB](#)
[CMLT3946EG TR](#) [SNSS40600CF8T1G](#) [CMLT3906EG TR](#) [GRP-DATA-JANS2N2907AUB](#) [GRP-DATA-JANS2N2222AUA](#)
[MMDT3946FL3-7](#) [2N4240](#) [MSB30KH-13](#) [2N2221AUB](#) [2SD1815T-TL-E](#)