

## IGBT Modules



**V<sub>CES</sub>**            1200V  
**I<sub>c</sub>**                 400A

### Applications

- Welding Machine
- Power Supplies
- Others

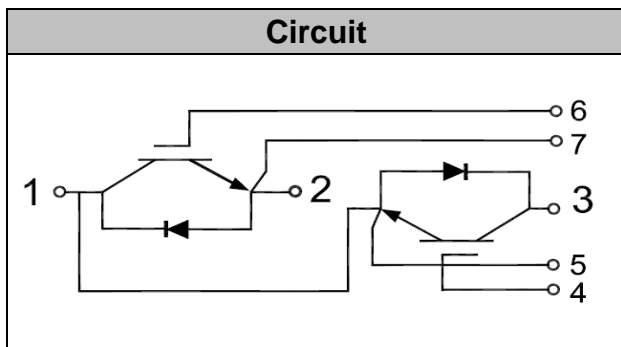

### Features

- Short circuit rated 10 $\mu$ s
- Low stray Inductance
- Low switching losses
- V<sub>CE(sat)</sub> with positive temperature coefficient
- Fast switching and short tail current
- Free wheeling diodes with fast and soft reverse recovery

### Absolute Maximum Ratings (T<sub>c</sub> = 25°C unless otherwise specified)

Symbol	Description	Values	Units
V <sub>CES</sub>	Collector - Emitter Voltage	1200	V
V <sub>GES</sub>	Gate-Emitter Voltage	±20	V
I <sub>c</sub>	DC Collector Current	T <sub>c</sub> =25°C	450 A
		T <sub>c</sub> =80°C	300 A
I <sub>CM</sub>	Repetitive Peak Collector Current	T <sub>c</sub> =25°C, t <sub>p</sub> =1ms	600 A
P <sub>tot</sub>	Power Dissipation Per IGBT		1760 W
T <sub>J</sub>	Junction Temperature Range		40 to +150 °C
T <sub>STG</sub>	Storage Temperature Range		40 to +125 °C
Viso	Insulation Test Voltage	AC, t=1min	3000 V
Mounting Torque	Power Terminals Screw: M6		5±15% N*m
	Mounting Screw:M6		5±15% N*m

Notes :

(1) Repetitive Rating: Pulse width limited by max. junction temperature



**Electrical Characteristics of IGBT** ( $T_J = 25^\circ\text{C}$  unless otherwise specified)

Symbol	Item	Conditions	Values			Units
			Min.	Typ.	Max.	
<b>OFF Characteristics</b>						
$V_{(BR)CES}$	Collector-Emitter Breakdown Voltage	$V_{GE}=0V, I_C=1mA$	1200			V
$I_{CES}$	Collector Leakage Current	$V_{CE}=1200V, V_{GE}=0V, T_J=25^\circ\text{C}$			0.5	mA
		$V_{CE}=1200V, V_{GE}=0V, T_J=125^\circ\text{C}$			1	mA
$I_{GES}$	Gate Leakage Current	$V_{CE}=0V, V_{GE}=\pm 20V$	-200		200	nA
<b>ON Characteristics</b>						
$V_{GE(th)}$	Gate - Emitter Threshold Voltage	$V_{CE}=V_{GE}, I_C=6mA$	5	6.0	7	V
$V_{CE(sat)}$	Collector – Emitter Saturation Voltage	$I_C=300A, V_{GE}=15V, T_J=25^\circ\text{C}$		1.8	2.0	V
		$I_C=300A, V_{GE}=15V, T_J=125^\circ\text{C}$		2.0	2.3	V
<b>Dynamic Characteristics</b>						
$C_{ies}$	Input Capacitance	$V_{CE}=25V, V_{GE}=0V, f=1MHz$		12.6		nF
$C_{res}$	Reverse Transfer Capacitance			0.45		nF
<b>Switching Characteristics</b>						
$t_{d(on)}$	Turn-on Delay Time	$V_{CC}=600V, I_C=300A, R_G=3.5\Omega, V_{GE}=\pm 15V, T_J=25^\circ\text{C}$ Inductive Load		162		ns
$t_r$	Rise Time			53		ns
$t_{d(off)}$	Turn-off Delay Time			376		ns
$T_f$	Fall Time			133		ns
$t_{d(on)}$	Turn-on Delay Time	$V_{CC}=600V, I_C=300A, R_G=3.5\Omega, V_{GE}=\pm 15V, T_J=125^\circ\text{C}$ Inductive Load		180		ns
$t_r$	Rise Time			56		ns
$t_{d(off)}$	Turn-off Delay Time			429		ns
$T_f$	Fall Time			292		ns
$E_{on}$	Turn-on Switching Loss	$V_{CC}=600V, R_G=3.5\Omega, I_C=300A$	$T_J=25^\circ\text{C}$		13.6	mJ
			$T_J=125^\circ\text{C}$		19.2	mJ
$E_{off}$	Turn-off Switching Loss	$V_{CC}=600V, R_G=3.5\Omega, I_C=300A$	$T_J=25^\circ\text{C}$		22.9	mJ
			$T_J=125^\circ\text{C}$		33.8	mJ
$Q_{ge}$	Gate Charge	$V_{CC}=600V, I_C=300A, V_{GE}=\pm 15V$		590		nC
SCSOA	Short Circuit Safe Operating Area	$V_{CC}=600V, V_{GE}\leq 15V, T_J=125^\circ\text{C}$	10			$\mu\text{s}$
				1700		A

**Electrical Characteristics of FWD** ( $T_C = 25^\circ\text{C}$  unless otherwise specified)

Symbol	Item	Conditions		Min.	Typ.	Max.	Units
$V_{FM}$	Forward Voltage	$I_F=300\text{A}$ , $V_{GE}=0\text{V}$ ;	$T_J=25^\circ\text{C}$ ,		1.81	2.0	V
			$T_J=125^\circ\text{C}$ ,		1.95	2.3	
$t_{rr}$	Reverse Recovery Time	$I_F=300\text{A}$ , $V_R=600\text{V}$ , $di_F/dt=-2885\text{A}/\mu\text{s}$ $V_{GE} = -15\text{V}$	$T_J=25^\circ\text{C}$ ,		198		ns
			$T_J=125^\circ\text{C}$ ,		365		
$I_{rr}$	Peak Reverse Recovery Current	$I_F=300\text{A}$ , $V_R=600\text{V}$ , $di_F/dt=-2885\text{A}/\mu\text{s}$ $V_{GE} = -15\text{V}$	$T_J=25^\circ\text{C}$ ,		185		A
			$T_J=125^\circ\text{C}$ ,		200		
$Q_{rr}$	Reverse Recovery Charge	$I_F=300\text{A}$ , $V_R=600\text{V}$ , $di_F/dt=-2885\text{A}/\mu\text{s}$ $V_{GE} = -15\text{V}$	$T_J=25^\circ\text{C}$ ,		15.9		mJ
			$T_J=125^\circ\text{C}$ ,		29.1		

**Thermal Resistance Characteristics**

Symbol	Description	Min.	Typ.	Max.	Units
$R_{\theta JC}$	Junction-To-Case (IGBT Part, Per Leg)			0.07	$^\circ\text{C}/\text{W}$
$R_{\theta JC}$	Junction-To-Case (Diode Part, Per Leg)			0.17	$^\circ\text{C}/\text{W}$
$R_{\theta CS}$	Case-To-Sink (Conductive Grease Applied)			0.1	$^\circ\text{C}/\text{W}$
Mt	Power Terminals Screw:M6	3		5	N·m
Ms	Mounting Screw:M6	3		5	N·m
Weight	Weight Of Module			300	g



PRELIMINARY

MG400HF12MIC2

RoHS  
COMPLIANT

Package Outline Information

CASE: C2

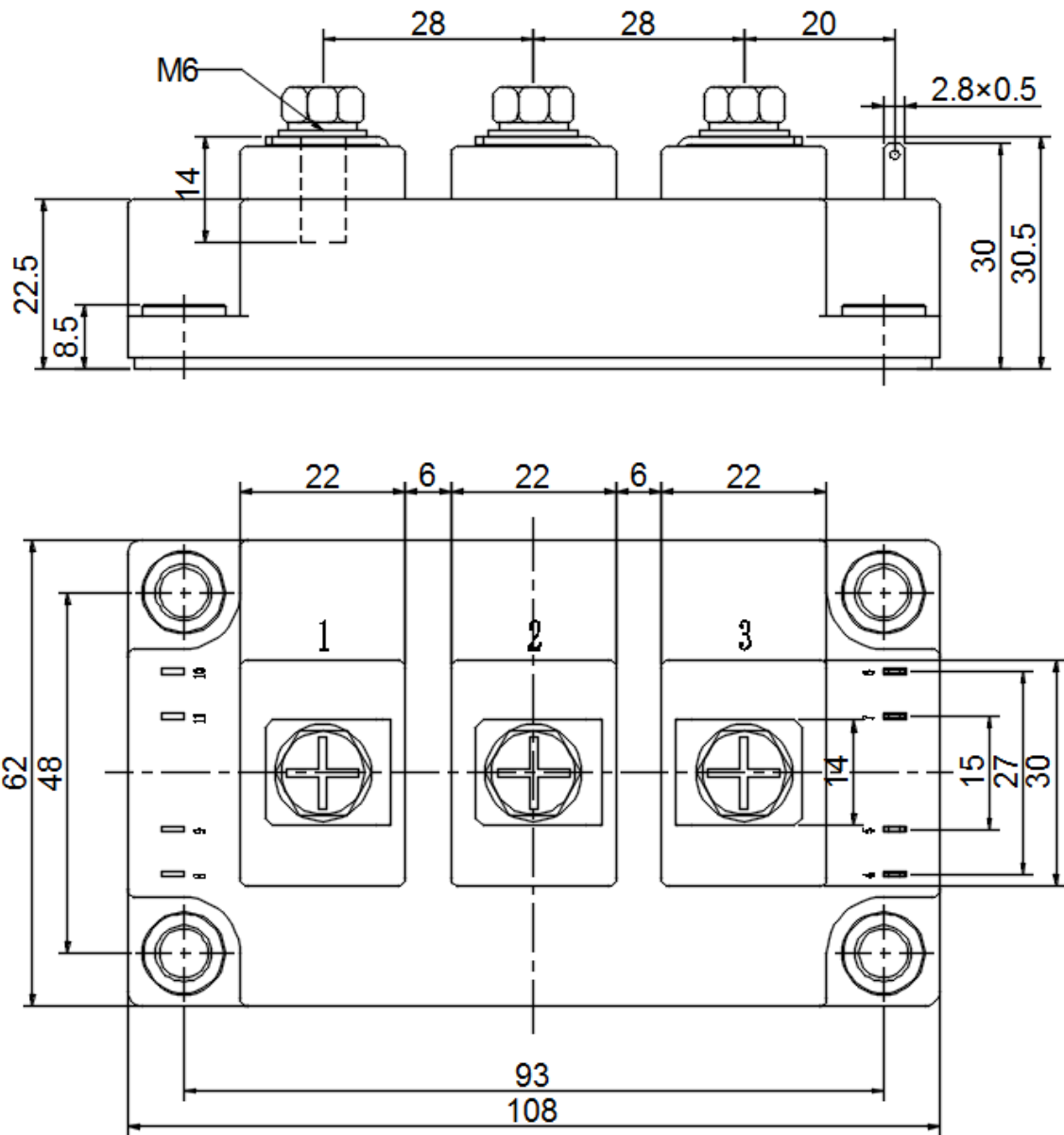

Dimensions in mm

## X-ON Electronics

Largest Supplier of Electrical and Electronic Components

*Click to view similar products for [IGBT Transistors](#) category:*

*Click to view products by [Yangjie](#) manufacturer:*

Other Similar products are found below :

[IRG4PC30W](#) [APT20GT60BRDQ1G](#) [STGWA25H120DF2](#) [APT30GS60BRDQ2G](#) [TIG058E8-TL-H](#) [IDW40E65D2](#) [STGB40V60F](#)  
[STGWA25H120F2](#) [NGTB75N65FL2WAG](#) [2MBI150VA-060-50](#) [NTE3320](#) [FGD3040G2-F085](#) [FGD3440G2-F085](#) [STGW80H65DFB-4](#)  
[AFGY160T65SPD-B4](#) [IGW30N60TP](#) [IGW40N60TP](#) [IGW50N60TP](#) [IHW30N65R5](#) [IKFW40N60DH3E](#) [IKP15N65H5](#) [IKQ100N60T](#)  
[IKQ120N60T](#) [IKW30N65WR5](#) [IKW75N60H3](#) [IKZ50N65NH5](#) [IKZ75N65NH5](#) [FGD3040G2-F085C](#) [FGH4L50T65SQD](#) [FGHL40T65MQDT](#)  
[FGHL50T65MQD](#) [FGHL50T65MQDTL4](#) [FGHL75T65LQDT](#) [FGHL75T65MQD](#) [FGHL75T65MQDT](#) [FGHL75T65MQDTL4](#)  
[FGY75T120SWD](#) [EL3120S1\(TA\)\(SAS\)-V](#) [IHW15N120E1](#) [IKQ75N120CS6](#) [IKW50N65WR5](#) [SL15T65FK](#) [KGF50N65KDF-U/H](#)  
[IHF40N65R5S](#) [IKW08N120CS7XKSA1](#) [IKQ75N120CH3](#) [IHW30N160R5](#) [SGM100HF12A1TFD](#) [CRG50T60AK3SD](#) [CRG40T60AN3S](#)