

## Dual NPN+PNP Small Signal Transistor

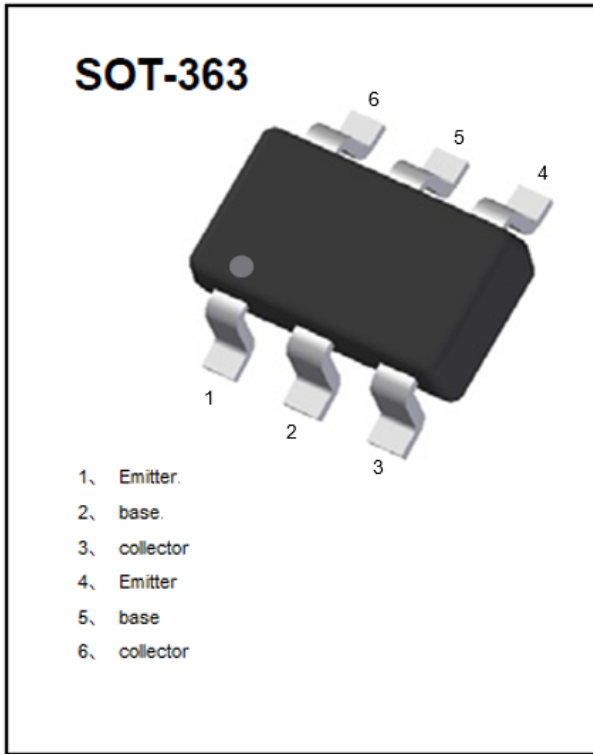

### Features

- Epoxy meets UL-94 V-0 flammability rating
- Surface mount package ideally Suited for Automatic Insertion
- NPN/PNP

### Mechanical Data

- **Package:** SOT-363
- **Terminals:** Tin plated leads, solderable per J-STD-002 and JESD22-B102
- **Marking:** K27

### Equivalent circuit

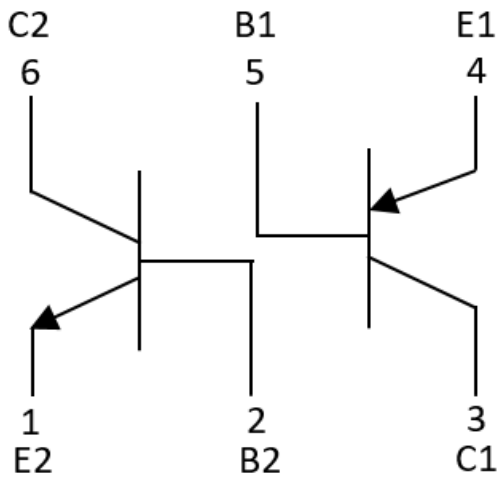

### Ordering Information (Example)

PREFERED P/N	PACKING CODE	UNIT WEIGHT(g)	MINIMUM PACKAGE(pcs)	INNER BOX QUANTITY(pcs)	OUTER CARTON QUANTITY(pcs)	DELIVERY MODE
MMDT2227	F2	Approximate 0.009g	3000	30000	120000	7" reel



# MMDT2227

## ■TR1 PNP Pin3、4、5 Maximum Ratings (Ta=25°C Unless otherwise specified)

Item	Symbol	Unit	Conditions	Value
Collector-Base Voltage	VCBO	V	IC=-10μA,IE=0	-60
Collector-Emitter Voltage	VCEO	V	IC=-10mA,IB=0	-60
Emitter-Base Voltage	VEBO	V	IE=-10μA,IC=0	-5
Collector Current -Continuous	IC	mA		-600
Total Device Dissipation	PC	mW		200
Junction Temperature	Tj	°C		150
Storage Temperature	TSTG	°C		-55 to +150

## ■TR1 PNP Pin3、4、5 Electrical Characteristics (Ta=25°C unless otherwise specified)

Item	Symbol	Unit	Conditions	Min	TYP	Max
Collector-base breakdown voltage	V <sub>CBO</sub>	V	IC=-10μA,IE=0	-60		
Collector-emitter breakdown voltage	V <sub>CEO</sub>	V	IC=-10mA,IB=0	-60		
Emitter-base breakdown voltage	V <sub>EBO</sub>	V	IE=-10μA,IC=0	-5		
Collector cut-off current	I <sub>CBO</sub>	nA	VCB=-50V,IE=0			-10
Collector cut-off current	I <sub>CEx</sub>	nA	VCE=-30V,VEB(off)=-0.5V			-50
Emmitter cut-off current	I <sub>EBO</sub>	nA	VEB=-5V, IC=0			-10
DC current gain	h <sub>FE1</sub>		VCE=-10V,IC=-0.1mA	75		
	h <sub>FE2</sub>		VCE=-10V,IC=-1mA	100		
	h <sub>FE3</sub>		VCE=-10V,IC=-10mA	100		
	h <sub>FE4</sub>		VCE=-10V,IC=-150mA	100		300
	h <sub>FE5</sub>		VCE=-10V,IC=-500mA	50		
Collector-emitter saturation voltage	V <sub>CE(sat)</sub>	V	IC=-150mA,IB=-15mA			-0.4
Collector-emitter saturation voltage	V <sub>CE(sat)</sub>	V	IC=-500mA,IB=-50mA			-1.6
Base-emitter saturation voltage	V <sub>BE(sat)</sub>	V	IC=-150mA,IB=-15mA			-1.3
Base-emitter saturation voltage	V <sub>BE(sat)</sub>	V	IC=-500mA,IB=-50mA			-2.6
Transition frequency	f <sub>T</sub>	MHz	VCE=-20V,IC=-50mA,f=100MHz	200		
Delay time	t <sub>d</sub>	ns	VCC=-30V,IC=-150mA,IB1=-15mA			10
Rise time	t <sub>r</sub>	ns				40
Storage time	t <sub>s</sub>	ns	VCC=-6V,IC=-150mA,IB1=-IB2=-15mA			225
Fall time	t <sub>f</sub>	ns				60



# MMDT2227

## ■TR2 NPN Pin1、2、6 Maximum Ratings (Ta=25°C Unless otherwise specified)

Item	Symbol	Unit	Conditions	Value
Collector-Base Voltage	V <sub>CBO</sub>	V	IC=10μA,IE=0	75
Collector-Emitter Voltage	V <sub>CEO</sub>	V	IC=10mA,IB=0	40
Emitter-Base Voltage	V <sub>EBO</sub>	V	IE=10μA,IC=0	6
Collector Current -Continuous	IC	mA		600
Total Device Dissipation	PC	mW		200
Junction Temperature	T <sub>j</sub>	°C		150
Storage Temperature	TSTG	°C		-55 to +150

## ■TR2 NPN Pin1、2、6 Electrical Characteristics (Ta=25°C unless otherwise specified)

Item	Symbol	Unit	Conditions	Min	TYP	Max
Collector-base breakdown voltage	V <sub>CBO</sub>	V	IC=10μA,IE=0	75		
Collector-emitter breakdown voltage	V <sub>CEO</sub>	V	IC=10mA,IB=0	40		
Emitter-base breakdown voltage	V <sub>EBO</sub>	V	IE=10μA,IC=0	6		
Collector cut-off current	I <sub>CBO</sub>	nA	V <sub>CB</sub> =60V,IE=0			10
Collector cut-off current	I <sub>CEX</sub>	nA	V <sub>CE</sub> =60V,V <sub>EB(off)</sub> =3V			10
Emmitter cut-off current	I <sub>EBO</sub>	nA	V <sub>EB</sub> =3V, IC=0			10
Base cut-off Current	I <sub>BL</sub>	nA	V <sub>CE</sub> =60V,V <sub>EB(off)</sub> =3V			20
DC current gain	h <sub>FE1</sub>		V <sub>CE</sub> =10V,IC=0.1mA	35		
	h <sub>FE2</sub>		V <sub>CE</sub> =10V,IC=1mA	50		
	h <sub>FE3</sub>		V <sub>CE</sub> =10V,IC=10mA	75		
	h <sub>FE4</sub>		V <sub>CE</sub> =10V,IC=150mA	100		300
	h <sub>FE5</sub>		V <sub>CE</sub> =1V,IC=150mA	35		
	h <sub>FE6</sub>		V <sub>CE</sub> =10V,IC=500mA	40		
Collector-emitter saturation voltage	V <sub>CE(sat)</sub>	V	IC=150mA,IB=15mA			0.3
Collector-emitter saturation voltage	V <sub>CE(sat)</sub>	V	IC=500mA,IB=50mA			1
Base-emitter saturation voltage	V <sub>BE(sat)</sub>	V	IC=150mA,IB=15mA			1.2
Base-emitter saturation voltage	V <sub>BE(sat)</sub>	V	IC=500mA,IB=50mA			2
Transition frequency	f <sub>T</sub>	MHz	V <sub>CE</sub> =20V,IC=20mA,f=100MHz	300		
Delay time	t <sub>d</sub>	ns	V <sub>CC</sub> =30V,IC=150mA, IB1=15mA,V <sub>BE(off)</sub> =-0.5V			10
Rise time	t <sub>r</sub>	ns				25
Storage time	t <sub>s</sub>	ns	V <sub>CC</sub> =30V,IC=150mA, IB1=- IB2=5mA			225
Fall time	t <sub>f</sub>	ns				60



# MMDT2227

## ■ TR1 PNP Pin3、4、5 Characteristics (Typical)

Static Characteristic

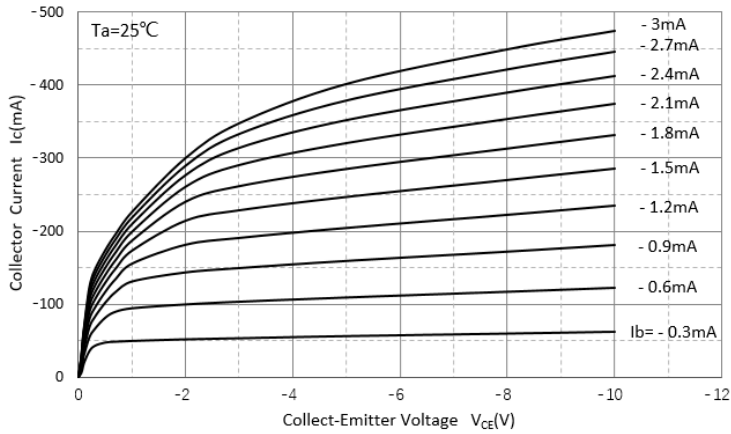

DC Current Gain

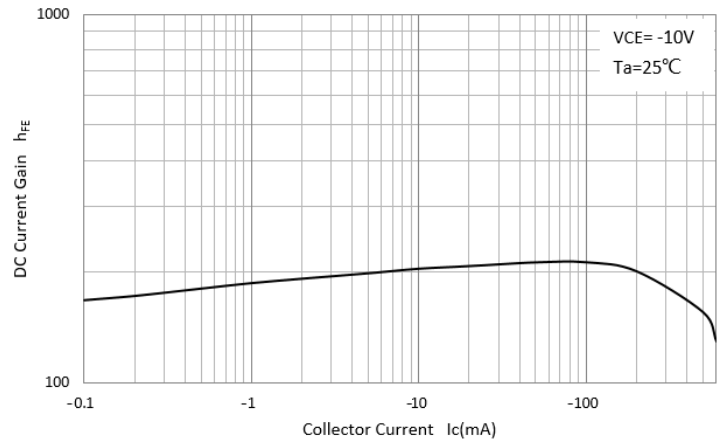

Collector-Emittor Saturation Voltage

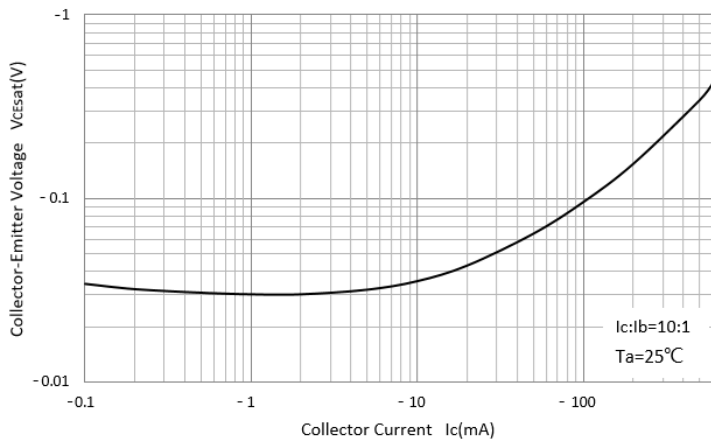

Base-Emittor Saturation Voltage

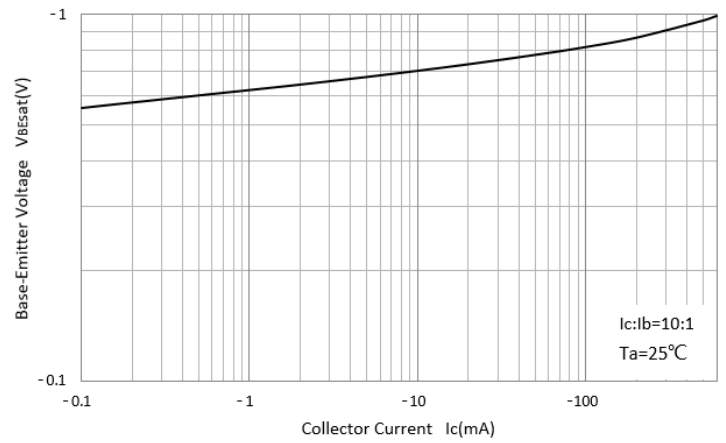

Base-Emittor On Voltage

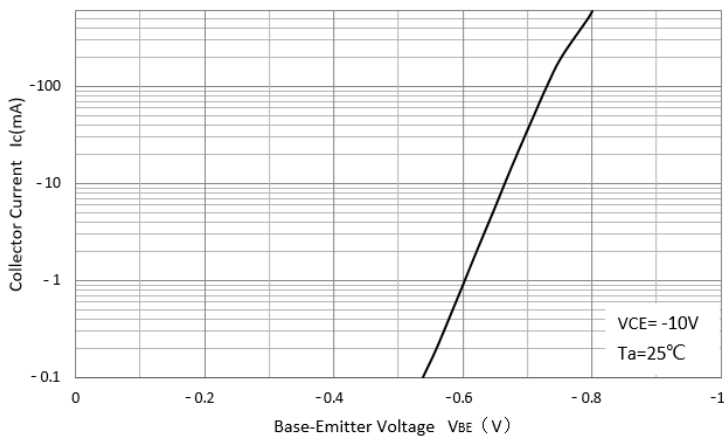

$C_{ob}/C_{ib}-V_{CB}/V_{EB}$

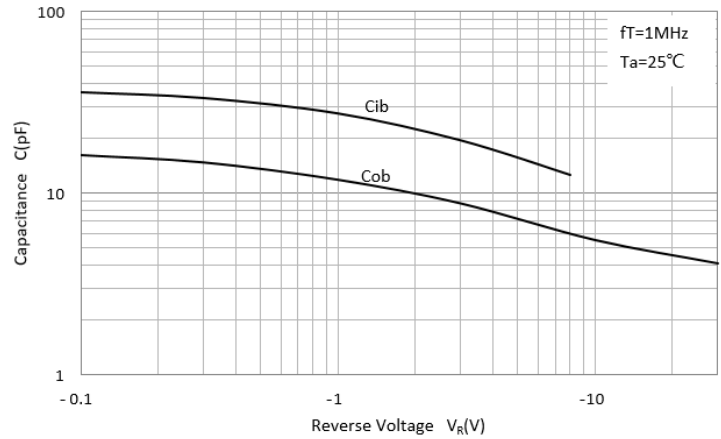



# MMDT2227

## ■ TR2 NPN Pin1、2、6 Characteristics (Typical)

### Static Characteristic

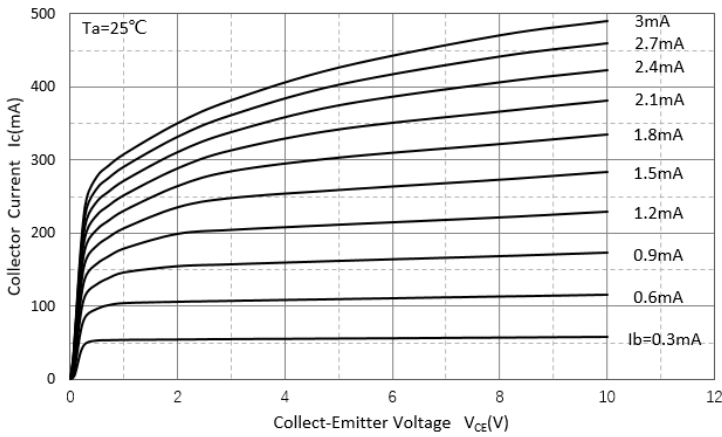

### DC Current Gain

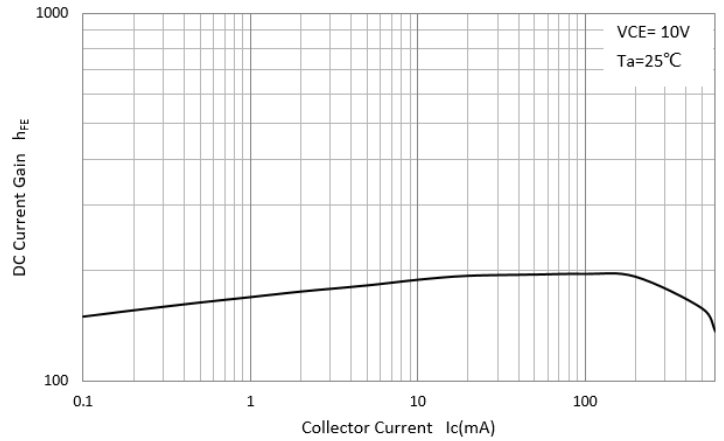

### Collector-Emitter Saturation Voltage

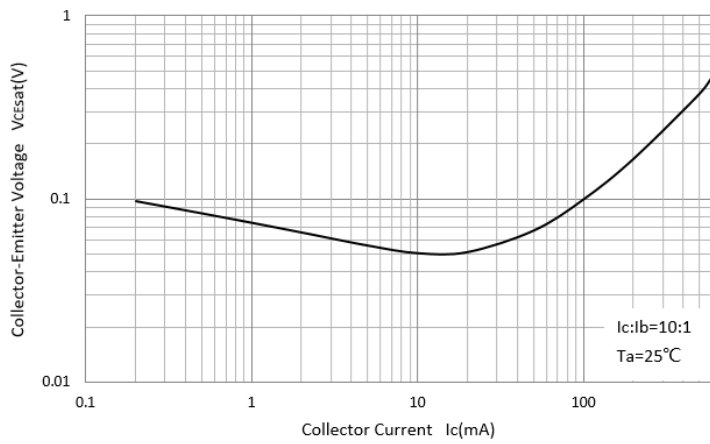

### Base-Emitter Saturation Voltage

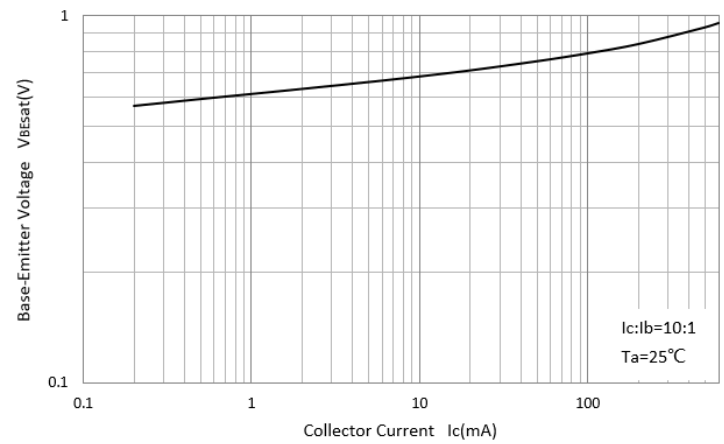

### Base-Emitter On Voltage

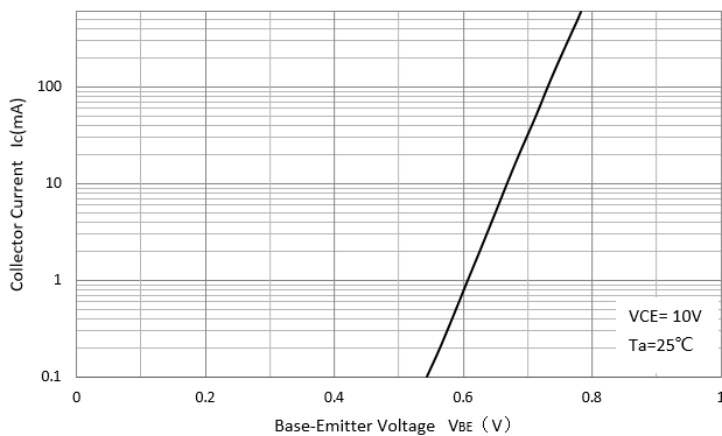

### Cob/Cib-V<sub>CB</sub>/V<sub>EB</sub>

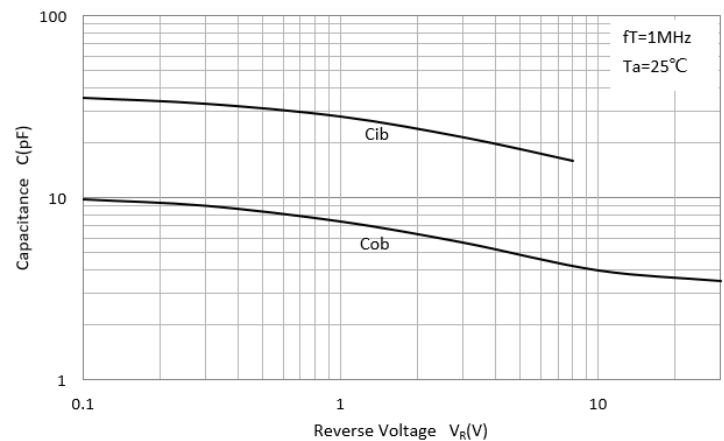



# MMDT2227

## ■SOT-363 Package Outline Dimensions

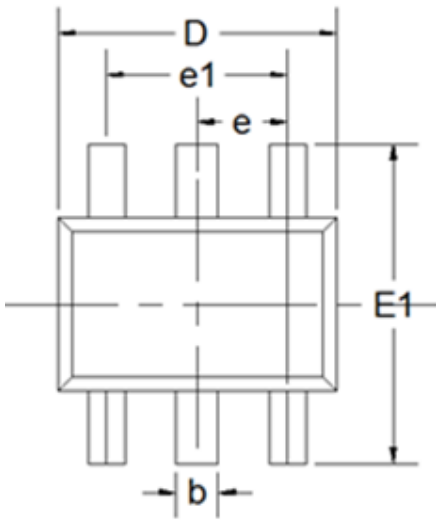

DIM	DIMENSIONS			
	INCHES		MM	
	MIN	MAX	MIN	MAX
A	0.035	0.043	0.9	1.1
A1	0	0.004	0	0.1
A2	0.035	0.039	0.9	1
b	0.006	0.014	0.15	0.35
c	0.002	0.01	0.05	0.25
D	0.071	0.087	1.8	2.2
E	0.045	0.053	1.15	1.35
E1	0.085	0.096	2.15	2.45
e	0.026Typ		0.65Typ	
e1	0.047	0.055	1.2	1.4
L	0.021Typ		0.525Typ	
L1	0.01	0.018	0.26	0.46
φ	0°	8°	0°	8°

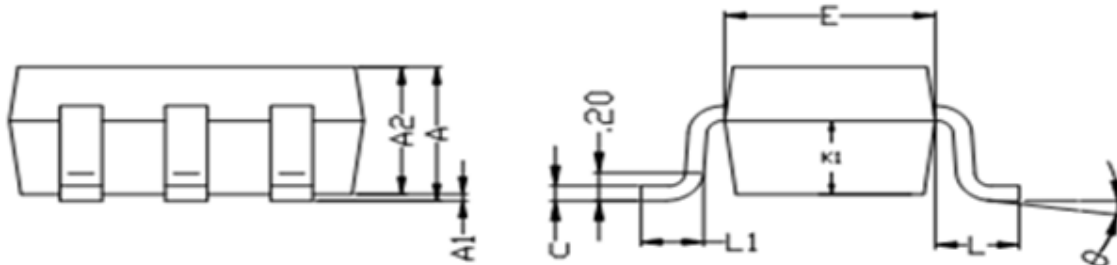

## ■SOT-363 Soldering Footprint

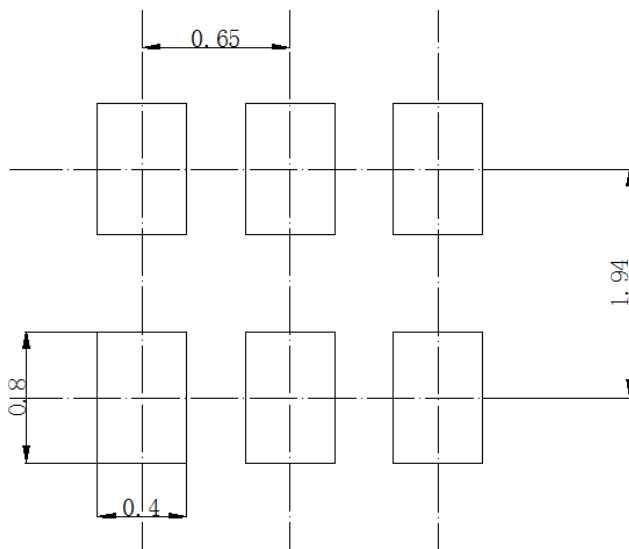

Unit: mm



## Disclaimer

The information presented in this document is for reference only. Yangzhou Yangjie Electronic Technology Co., Ltd. reserves the right to make changes without notice for the specification of the products displayed herein to improve reliability, function or design or otherwise.

The product listed herein is designed to be used with ordinary electronic equipment or devices, and not designed to be used with equipment or devices which require high level of reliability and the malfunction of which would directly endanger human life (such as medical instruments, transportation equipment, aerospace machinery, nuclear-reactor controllers, fuel controllers and other safety devices), Yangjie or anyone on its behalf, assumes no responsibility or liability for any damages resulting from such improper use of sale.

This publication supersedes & replaces all information previously supplied. For additional information, please visit our website [http:// www.21yangjie.com](http://www.21yangjie.com) , or consult your nearest Yangjie's sales office for further assistance.

## X-ON Electronics

Largest Supplier of Electrical and Electronic Components

*Click to view similar products for [Bipolar Transistors - BJT category](#):*

*Click to view products by [Yangjie manufacturer](#):*

Other Similar products are found below :

[BC559C](#) [MCH4017-TL-H](#) [MMBT-2369-TR](#) [BC546/116](#) [NJVMJD148T4G](#) [NTE16](#) [NTE195A](#) [IMX9T110](#) [2N4401-A](#) [2N6728](#) [2SA1419T-TD-H](#) [2SB1204S-TL-E](#) [2SC5488A-TL-H](#) [FMC5AT148](#) [2N2369ADCSM](#) [2N2907A](#) [2N3904-NS](#) [2N5769](#) [2SC4618TLN](#) [CPH6501-TL-E](#) [US6T6TR](#) [BAX18/A52R](#) [BC556/112](#) [IMZ2AT108](#) [MMST8098T146](#) [MCH6102-TL-E](#) [BC846B-13-F](#) [2N3879](#) [30A02MH-TL-E](#) [NTE13](#) [NTE282](#) [NTE323](#) [NTE350](#) [NTE81](#) [JANTX2N2920L](#) [JANSR2N2907AUB](#) [CMLT3946EG TR](#) [SNSS40600CF8T1G](#) [CMLT3906EG TR](#) [GRP-DATA-JANS2N2907AUB](#) [GRP-DATA-JANS2N2222AUA](#) [MMDT3946FL3-7](#) [2N4240](#) [JANS2N3019](#) [MSB30KH-13](#) [2N2221AUB](#) [2SD1815T-TL-E](#) [2N6678](#) [2N2907Ae4](#) [JAN2N3507](#)