

Surface Mount Transient Voltage Suppressor

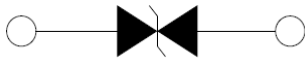

Features

- Ideal for automated placement
- High surge current capability
- Meets MSL level 1, per J-STD-020, LF maximum peak of 260 °C
- Bi-directional TVS
- Glass passivated junction
- Low clamping voltage under surge

Typical Applications

- High power DC bus protection

Mechanical Data

- **Package:** SME
Molding compound meets UL 94 V-0 flammability rating, RoHS-compliant
- **Terminals:** Tin plated leads, solderable per J-STD-002 and JESD22-B102

■ Maximum Ratings (T_a=25°C Unless otherwise specified)

PARAMETER	SYMBOL	UNIT	VALUE
Peak pulse current rating per 8/20μs IEC 61000-4-5	I _{pp}	A	10000
Storage temperature	T _{stg}	°C	-55 ~+150
Junction temperature	T _j	°C	-55 ~+125

■ Electrical Characteristics (T_A=25°C unless otherwise noted)

Part Number (Uni)	Breakdown Voltage VBR@IT			Maximum Reverse Leakage IR @VRWM (μA)	Working Peak Reverse Voltage VRWM (V)	Typical. Capacitance 0V Bias 10kHz (nF)	Maximum Clamping Voltage Vc @ IPP (V)
	Min (V)	Max (V)	IT (mA)				
SMEJ58CA	64	70	10	5	58	6.5	110
SMEJ66CA	72	80	10	5	66	6.5	120
SMEJ76CA	85	95	10	5	76	6.5	135
SMEJ86CA	96	107	10	5	86	6.0	157



SMEJ SERIES

Ordering Information (Example)

PREFERRED P/N	PACKING CODE	UNIT WEIGHT(g)	MINIMUM PACKAGE(pcs)	INNER BOX QUANTITY(pcs)	OUTER CARTON QUANTITY(pcs)	DELIVERY MODE
SMEJ	F1	Approximate 5.10	400	800	4000	13" reel

Performance Graphs

FIG.1 Pulse Derating Curve

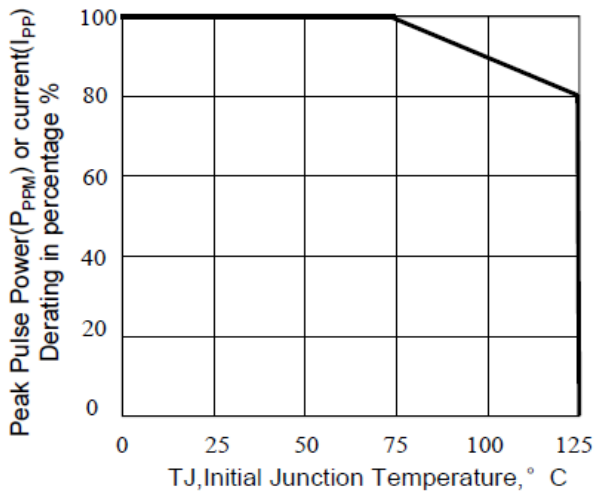

Fig.2 Current 8/20us Waveform per IEC 6100-4-5

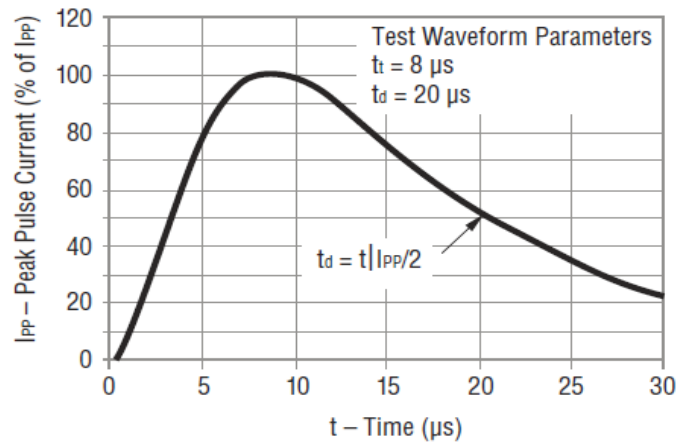
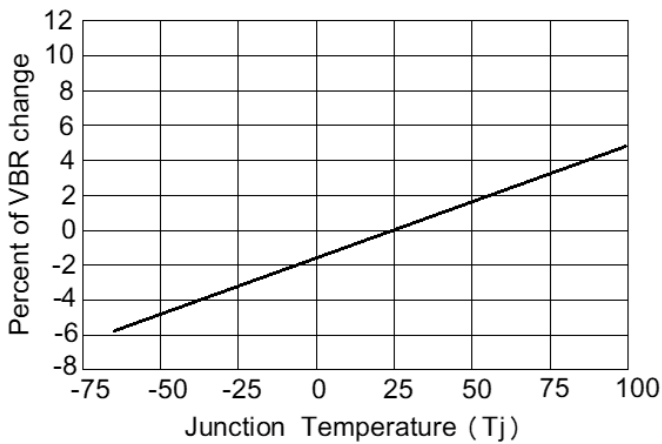

FIG.3: Typical VBR vs. junction temperature





SMEJ SERIES

■ Outline Dimensions

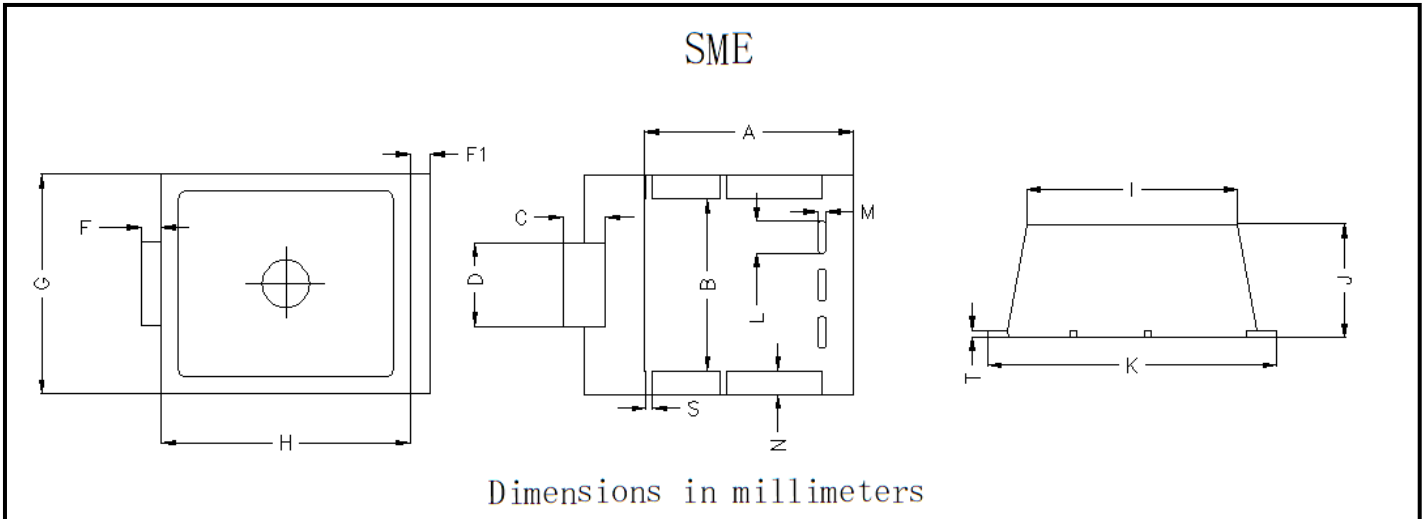

SME		
Dim	Min	Max
A	13.16	13.76
B	10.55	11.05
C	2.50	2.90
D	5.15	5.65
F1	1.20	1.40
F	1.20	1.40
G	13.45	14.60
H	15.50	16.05
J	6.94	7.24
K	18.1	18.5
L	1.9	2.1
M	0.4	0.6
N	1.4	1.6
T	0.33	0.43
S	0.35	0.45

■ Suggested pad layout

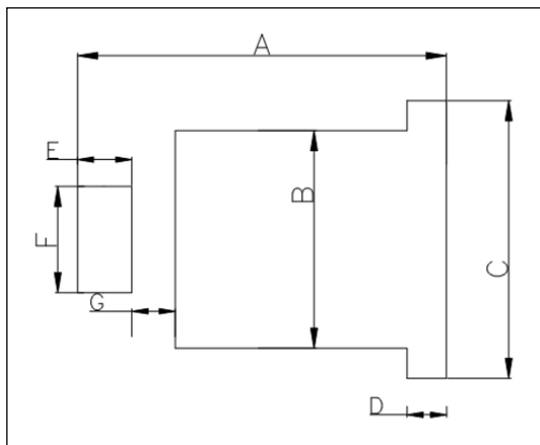

Dim	Millimeters
A	18.31
B	10.80
C	13.72
D	2.54
E	2.70
F	5.33
G	2.15



Disclaimer

The information presented in this document is for reference only. Yangzhou Yangjie Electronic Technology Co., Ltd. reserves the right to make changes without notice for the specification of the products displayed herein to improve reliability, function or design or otherwise.

The product listed herein is designed to be used with ordinary electronic equipment or devices, and not designed to be used with equipment or devices which require high level of reliability and the malfunction of which would directly endanger human life (such as medical instruments, transportation equipment, aerospace machinery, nuclear-reactor controllers, fuel controllers and other safety devices), Yangjie or anyone on its behalf, assumes no responsibility or liability for any damages resulting from such improper use of sale.

This publication supersedes & replaces all information previously supplied. For additional information, please visit our website [http:// www.21yangjie.com](http://www.21yangjie.com) , or consult your nearest Yangjie's sales office for further assistance.

X-ON Electronics

Largest Supplier of Electrical and Electronic Components

Click to view similar products for [ESD Suppressors / TVS Diodes](#) category:

Click to view products by [Yangjie](#) manufacturer:

Other Similar products are found below :

[60KS200C](#) [D18V0L1B2LP-7B](#) [D5V0F4U5P5-7](#) [NTE4902](#) [P4KE27CA](#) [P6KE11CA](#) [P6KE8.2A](#) [SA60CA](#) [SA64CA](#) [SMBJ12CATR](#)
[SMBJ33CATR](#) [SMBJ6.5A](#) [SMBJ8.0A](#) [ESD101-B1-02ELS E6327](#) [ESD112-B1-02EL E6327](#) [ESD7451N2T5G](#) [19180-510](#) [CPDT-5V0USP-](#)
[HF](#) [3.0SMCJ33CA-F](#) [3.0SMCJ36A-F](#) [HSPC16701B02TP](#) [JANTX1N6126A](#) [D3V3Q1B2DLP3-7](#) [D55V0M1B2WS-7](#) [SCM1293A-04SO](#)
[ESD200-B1-CSP0201 E6327](#) [SM12-7](#) [CEN955 W/DATA](#) [VESD12A1A-HD1-GS08](#) [CPDQC5V0-HF](#) [D1213A-01LP4-7B](#) [ESD101-B1-02EL](#)
[E6327](#) [AOZ8808DI-03](#) [5KP15A](#) [5KP48A](#) [5KP90A](#) [ESD3V3D7-TP](#) [15KPA36A-LF](#) [P4KE56CA](#) [P4KE68A](#) [P4KE91CATR](#) [P6KE120A](#)
[P6KE13CA](#) [P6KE43CA](#) [P6KE6.8CA](#) [P6KE8.2](#) [P6SMBJ20CA](#) [JANTX1N6072A](#) [SR2835ESKG](#) [SA90CA](#)