

深圳扬兴科技有限公司

产 品 规 格 书

SPECIFICATION

产品名称	石英晶体谐振器 QUARTZ CRYSTAL UNITS
型号	YSX146GA
料号	XKYGI-STX-32.768K
标准参数	SMD-7015-32.768KHZ-12.5PF- -/+20PPM
页次	共6页

确 认 签 章

客 户		
客户物料号		
机种/型号		
批 准	审 核	检 验

扬 兴 签 核

制 定	审 核	批 准
康明红		

深圳扬兴科技有限公司

Shenzhen YangXing Technology Co.,Ltd.

地址： 深圳市龙华区民治街道民塘路385号汇德大厦1号楼19层

ADDRESS: 19th Floor, 1st Huide Building, Mintang Rd No.385, Longhua District, Shenzhen

TEL: 0755-28444777

WEB: <http://www.yxc.hk>

MHz Range Crystal unit

YSX146GA

Product name 系列型号

YSX146GA 32.76800 KHz 12.5PF +/-20PPM

Product Number / Ordering code 产品料号 XKYGI-STX-32.768K

1. Absolute maximum ratings

Parameter(电气参数)	Symbol	Min. (最小值)	Typ.(典型值)	Max. (最大值)	Unit (单位)
Storage temperature (储存温度)	T_stg	-55	-	125	°C

2. Specifications (characteristics)(规格参数)

Parameter(电气参数)	Symbol	Min. (最小值)	Typ.(典型值)	Max. (最大值)	Unit (单位)
Type (型号)	YSX146GA				
Cutting Mode (切割方式)	☑ X +2°				
Nominal frequency (标称频率)	f_nom	-	32.768	-	KHz
Frequency tolerance at 25°C (常温频差)	f_tol	-20	-	20	x 10 ⁻⁶
Parabolic Coefficient(温飘系数)	B	-	-	- 0.04 Max.	x 10 ⁻⁶ / °C ²
Load capacitance(负载电容)	CL	-	12.5	-	pF
Motional resistance (ESR) (等效谐振电阻)	R1	-	-	65	KΩ
Shunt capacitance (静电容)	C0	-	0.8 Typ.	-	pF
Motional capacitance (动态电容)	C1	-	1.9 Typ.	-	fF
Level of drive (激励功率)	DL	0.01	0.1	0.5	μW
Operating temperature (工作温度)	T_use	-40	-	85	°C
Frequency aging (老化率)	f_age	-3	-	3	x10 ⁻⁶ /year

3. External dimensions (外观尺寸) (Unit: mm)

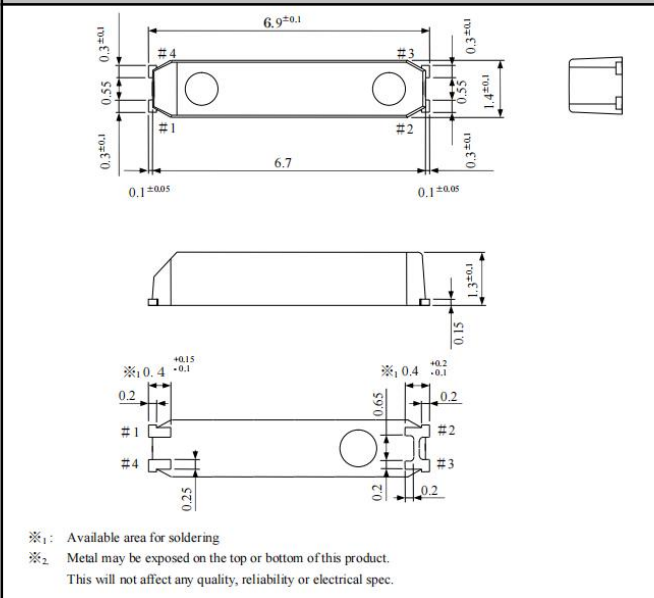

4. Footprint(Recommended) (焊盘推荐) (Unit: mm)

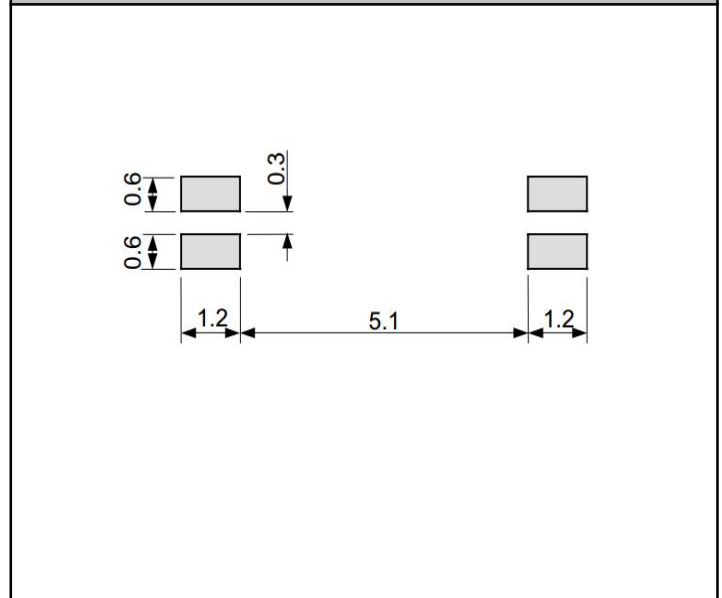

5. Marking information(丝印说明)

Symbol of Manufacturing year											
Year digit	1	2	3	4	5	6	7	8	9	0	
Marking	Terminal Plating: Sn	M	N	R	S	T	U	V	W	X	Z

Year digit(1st) of the Production

Symbol of Manufacturing month											
Month digit	1	2	3	4	5	6	7	8	9	10	12
Marking (Halide free)	A	B	C	D	E	F	G	H	J	K	M

6.Taping Specification (载带规格) (Unit: mm)

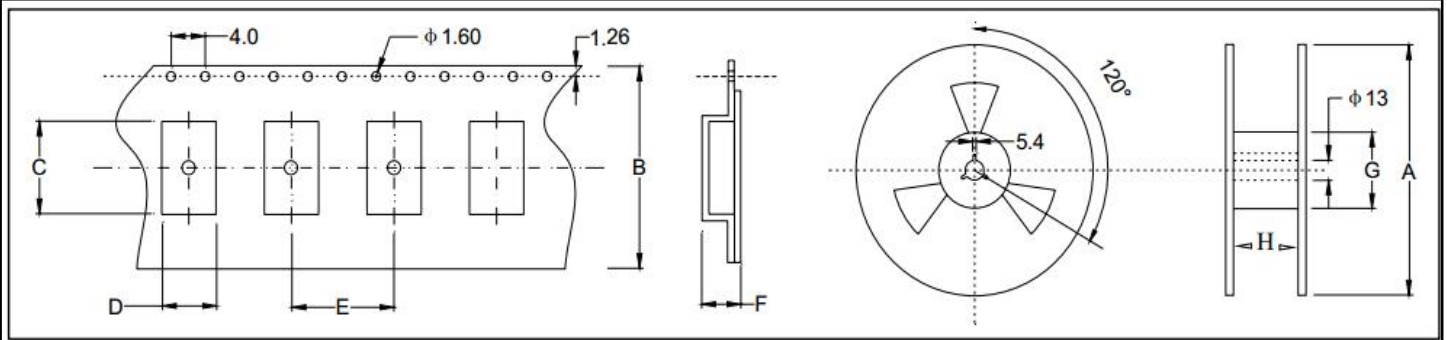

Size	A	B	C	D	E	F	G	H
SMD-7015	330±2.0	16.0±0.3	7.20±0.1	1.70±0.1	4.0±0.1	1.50±0.1	61.0±1.0	16.0±1.0

3000 pcs per reel

7.Reliability characteristic (可靠性)

NO (序号)	Item (项目)	Condition (环境条件)	Value *1*2 f/f [1 10 6]
7.1	Shock	100 g dummy (EPSON Standard) drop from 1500 mm height on to the concrete 3 directions 10 times	*3 ±5
7.2	Vibration	10 Hz to 55 Hz amplitude 0.75 mm 55 Hz to 500 Hz acceleration 98 m/s ² 10 Hz →500 Hz →10 Hz 15 min./cycle 6 h (2 hours , 3 directions)	*3 ±3
7.3	Resistance to soldering heat (Reflow characteristics)	For convention reflow soldering furnace (2 times)	*3 ±5
7.4	High temperature storage	a) + 125°C × 1 000 h b) + 85°C × 1 000 h	*3 a) ± 20 b) ± 10
7.5	Low temperature storage	- 55 °C × 1 000 h	*3 ±10
7.6	Temperature humidity storage	+ 85 °C × 85 %RH × 1000 h	*3 ±10
7.7	Temperature cycle	- 55 °C ↔ + 125 °C 30 minutes at each temperature 100 cycles	*3 ±10
7.8	Shear	10 N press the side for 10 s ± 1 s. Ref. IEC 60068-2-21	No peeling-off at a soldered part
7.9	Pull-off	10 N press the side for 10 s ± 1 s. Ref. IEC 60068-2-21	No peeling-off at a soldered part

7.10	Substrate bending	Bending width reaches 3mm and hold for 5 s ± 1 s $\times 1$ time Ref. IEC 60068-2-21	No peeling-off at a soldered part
7.11	Solderability	covered with fresh solder Dip termination into solder bath at $+ 235 \pm 5$ °C for 3 s (Using rosin flux)	Termination must be 95 % covered with fresh solder
7.12	Solvent resistance	Ref. JIS C 0052 or IEC 60068-2-45	The marking shall be legible

8.Reflow profile (回流焊)

Pre Heating Temperature

Tp1 ~ Tp2 = + 170 °C

Heating Temperature

TMit = + 220 °C

Peek Temperature

TMax. = + 260 °C

Point of measuring

In case of Solder ability

Terminal.

In case of Resistance to soldering heat

Surface.

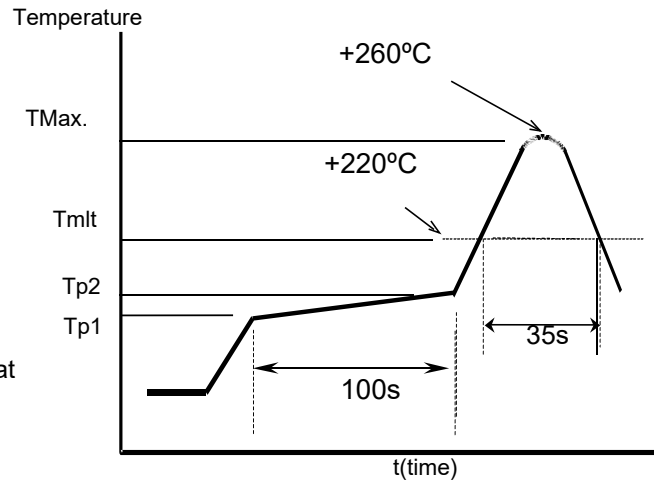

9.Notice (注意)

- 包装 PACKING
- 包装方式应符合运输和装卸要求，特殊包装须经双方认可。
- Packing must prevent damage during transportation and handing. Specific method will be settled by mutual agreement.
- 对环境影响 INFLUENCE TO ENVIRONMENT
- 本产品在生产过程中不使用 ODS I，对臭氧层无破坏。
- This product doesn't use the class I ODS at any of production process .
- 生产厂家 MANUFACTURE
- 公司名称：深圳扬兴科技有限公司
- Shenzhen YangXing Technology Co.,Ltd.
- 其它 OTHERS
- 1. 如果您对本公司产品规格书有疑问或书中未列出，请与我方联系，协商解决及改进。
- If you have some doubt or unknowing about this specification, Please contact us for settlement or development.
- 2.我们按照产品规格书要求保证晶体品质，若客户要求具体数据，我们可提供。
- We guarantee that quartz crystal unit satisfies this specification, If you need the data, we will provide it.
- 3.变更与联络 (MODIFY AND CONTACT)
- 本产品在设计、工艺、材料、生产厂所、关键设备、操作人员等影响产品质量的因素有变更时，应事先提供更改后的产品并经过质量认可后，方可大批量供货。
- When the quality is changed due to the changes of the design, technology, material, manufacture place, main equipment and workers, we will first supply the modified products and obtain approval from you, then start to supply mass production.
- 4.售前售后服务 (AFTER SALE SERVICE)
- 若在生产过程中遇到不良品，本公司负责调换，并及时提交不良品的分析及改进措施报告经认可。
- If the deflection product was found in the production process, we will exchange and provide the improving measures in time.

Contact us

www.yxc.hk

X-ON Electronics

Largest Supplier of Electrical and Electronic Components

Click to view similar products for [Crystals](#) category:

Click to view products by [Yangxing](#) manufacturer:

Other Similar products are found below :

[CX3225GB25000M0PPSZ1](#) [718-13.2-1](#) [7A-40.000MAAE-T](#) [FL2000085](#) [99-BU](#) [9B-15.360MBBK-B](#) [9C-7.680MBBK-T](#) [H10S-12.000-18-EXT-TR](#) [ABC2-6.000MHZ-D4Z-T](#) [ABLS-20.000MHZ-D2-T](#) [ABS071-32.768KHZ-6-T](#) [R38-32.768-12.5-5PPM-NPB](#) [BTD1062E05A-513](#) [21U15A-21.4MHZ](#) [RTX-781DF1-S-20.950](#) [LFXTAL066198Cutt](#) [9C-14.31818MBBK-T](#) [A-11.000MHZ-27](#) [ABL-27.000MHZ-B4Y-T](#) [ABM11-132-24.000MHZ-T3](#) [ABM3B1-25.000MHZ-D2Y-T](#) [SPT2A-.032768B](#) [SPT2A.032768G](#) [LFXTAL065253Cutt](#) [LFXTAL066431Cutt](#) [XT9S20ANA14M7456](#) [XT9SNLANA16M](#) [7A-24.576MBBK-T](#) [7B-30.000MBBK-T](#) [CX2520DB16000H0HPQCC](#) [MMCC2R32.7680KHZ](#) [6504-202-1501](#) [6526-202-1501](#) [ABLS-12.000MHZ-B2Y-T](#) [7A-10.000MBBK-T](#) [SG636PCE-20.000MC](#) [3404](#) [CM315D32768EZFT](#) [C1E-24.000-7-2020-R](#) [C1E-19.200-12-1530-X-R](#) [C1E-16.000-12-1530-X-R](#) [ABM11-16.000MHZ-9-B1U-T](#) [FL5000014](#) [EUCA18-3.1872M](#) [FX0800015](#) [425F35E027M0000](#) [FP0800018](#) [MS3V-T1R-32.768kHz-7pF-20PPM-TA-QC-Au](#) [VXM7-1C1-16M000](#) [MS3V-T1R-32.768kHz-9pF-20PPM-TA-QC-Au](#)