

- ◇ Low Forward Voltage Drop
- ◇ **SOD523** Micro SMD Package
- ◇ RoHS Compliant / Green EMC
- ◇ Matte Tin (Sn) Lead Finish
- ◇ Cathode Band / Device Marking
- ◇ Surface Mount Package Ideally Suited For Automatic Insertion

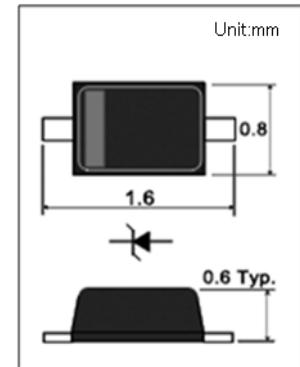

### Maximum Ratings (Ta = 25 °C)

Symbol	Parameter	Value	Units
$V_{RRM}$	Peak Repetive Reverse Voltage	40	V
$V_{RWM}$	Working Peak Reverse Voltage	40	V
$V_R$	DC Blocking Voltage	40	V
$V_{R(RMS)}$	RMS Reverse Voltage	28	V
$I_{FM}$	Forward Continuous Current	350	mA
$I_{FSM}$	Non-Repetitive Peak Forward Surge Current ( @t=8..3ms )	2.0	A
$P_D$	Power Dissipation	200	mW
$T_J$	Junction Temperature	125	°C
$T_{STG}$	Storage Temperature	-55 to +150	°C
$R_{\theta JA}$	Thermal Resistance From Junction To Ambient	625	°C/W

### Electrical Characteristics (Ta = 25 °C)

Symbol	Parameter	Conditions	Min	Typ	Max	Units
$V_{BR}$	Reverse Voltage	$I_F = 100\mu A$	40			V
$V_F$	Forward Voltage	$I_F = 20mA$			0.37	V
		$I_F = 200mA$			0.60	V
$I_R$	Reverse current	$V_R = 30V$			5	$\mu A$
$C_T$	Capacitance	$V_R = 0V, f = 1MHz$			50	pF
$t_{rr}$	Typical Reverse Recovery Time	$I_F = I_R = 200mA,$ $I_{rr} = 0.1 * I_R, R_L = 100 \Omega$		10		ns

### Curve Characteristics

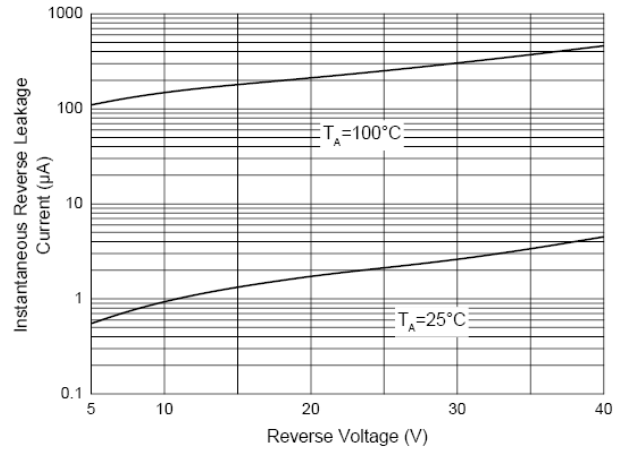
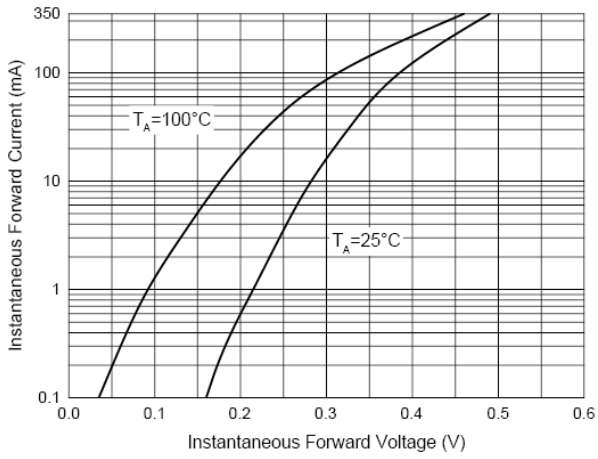

### Typical Instantaneous Forward Characteristics

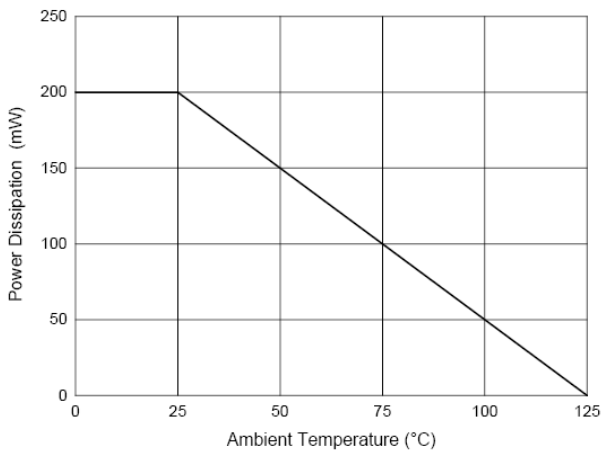

### Typical Reverse Leakage Characteristics

### Power Derating Curve

## Package Dimensions

Package outline : SOD-523

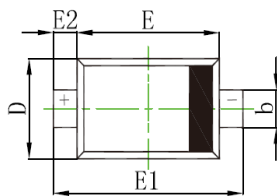
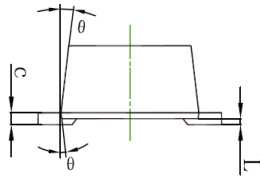

Unit	A	A1	b	c	D	E	E1	E2	L	$\theta$
Max.	0.70	0.70	0.35	0.15	0.85	1.30	1.70	0.25	0.07	7° REF.
Min.	0.51	0.50	0.25	0.08	0.75	1.10	1.50	0.15	0.01	

SOD523Package Outline

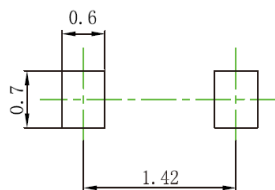

Land Pattern Recommendation

Note:

1. Halogen free, EMC
2. Pb free solder
3. Lead thickness includes solder plating
4. Lead frame: Cu
5. Other Tolerance:  $\pm 0.05$
6. Dimensions are exclusive of Burrs, Mold Flash and Tie Bar extrusions
7. Unit: mm

## X-ON Electronics

Largest Supplier of Electrical and Electronic Components

*Click to view similar products for [Schottky Diodes & Rectifiers](#) category:*

*Click to view products by [Yongyutai Electronics](#) manufacturer:*

Other Similar products are found below :

[MA4E2039](#) [MA4E2508M-1112](#) [MBR1545CT](#) [MMBD301M3T5G](#) [RB160M-50TR](#) [D83C](#) [BAS16E6433HTMA1](#) [BAT 54-02LRH E6327](#)  
[NRVBAF360T3G](#) [NSR05F40QNXT5G](#) [NTE555](#) [JANS1N6640](#) [SK310-T](#) [SK34B-TP](#) [SS3003CH-TL-E](#) [GA01SHT18](#)  
[CRS10I30A\(TE85L,QM](#) [MA4E2501L-1290](#) [MBRA140TRPBF](#) [MBRB30H30CT-1G](#) [BAT 15-04R E6152](#) [JANTX1N5712-1](#) [DMJ3940-000](#)  
[SB007-03C-TB-E](#) [SK33B-TP](#) [NRVBB20100CTT4G](#) [NRVBM120LT1G](#) [NTSB30U100CT-1G](#) [VS-6CWQ10FNHM3](#) [CRG04\(T5L,TEMQ\)](#)  
[ACDBA1100LR-HF](#) [ACDBA1200-HF](#) [ACDBA240-HF](#) [ACDBA3100-HF](#) [CDBQC0530L-HF](#) [CDBQC0240LR-HF](#) [ACDBA260LR-HF](#)  
[ACDBA1100-HF](#) [MA4E2502L-1246](#) [10BQ015-M3/5BT](#) [NRVBM120ET1G](#) [CRS08TE85LQM](#) [PMAD1108-LF](#) [B120Q-13-F](#) [1N5819T-G](#)  
[B0530WSQ-7-F](#) [PDS1040Q-13](#) [B160BQ-13-F](#) [SDM05U20CSP-7](#) [B140S1F-7](#)