

## SCHOTTKY BARRIER RECTIFIERS

### FEATURES

- Low Forward Voltage Drop
- Fast Switching Time
- Surface Mount Package Ideally Suited for Automated Insertion
- Lead, Halogen and Antimony Free, RoHS Compliant "Green" Device

### PINNING

PIN	DESCRIPTION
1	Cathode
2	Anode

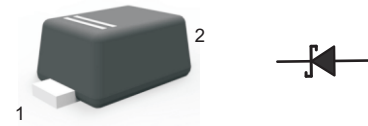

Top View  
Simplified outline SOD-523 and symbol

Maximum Ratings and Electrical characteristics  
Ratings at 25 °C ambient temperature unless otherwise specified.

Parameter		Symbols	B5819WT	Units
Peak Repetitive Reverse Voltage		$V_{RRM}$	40	V
Working Peak Reverse Voltage		$V_{RWM}$		
DC Blocking Voltage		$V_R$		
RMS Reverse Voltage		$V_{R(RMS)}$	28	V
Forward Continuous Current		$I_F$	200	mA
Non-Repetitive Peak Forward Surge Current @t = 8.3ms		$I_{FSM}$	0.5	A
Power dissipation		$P_D$	200	mW
Reverse Breakdown Voltage	$I_R = 100\mu A$	$V_{BR}$	40(Min)	V
Forward Voltage	$I_F = 1.0\text{ mA}$ $I_F = 5.0\text{ mA}$ $I_F = 20\text{ mA}$ $I_F = 200\text{ mA}$	$V_F$	0.27(Typ) 0.32(Typ) 0.37(Max) 0.60(Max)	V
Peak Reverse Current	$V_R = 30\text{ V}$	$I_R$	5.0(Max)	$\mu A$
Typical Junction Capacitance	$V_R = 4\text{ V}, f = 1\text{ MHz}$	$C_T$	50	pF
Junction Temperature		$T_j$	125	°C
Storage Temperature		$T_{stg}$	-55 ~ +150	°C

**Fig.1 Power Derating Curve**

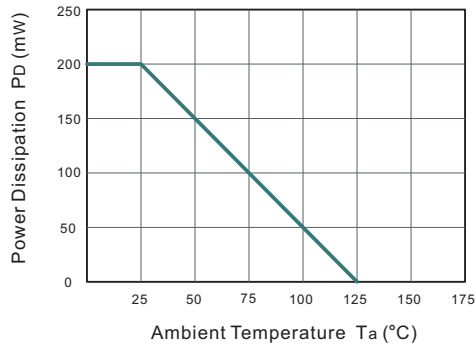

**Fig.2 Typical Instantaneous Reverse Characteristics**

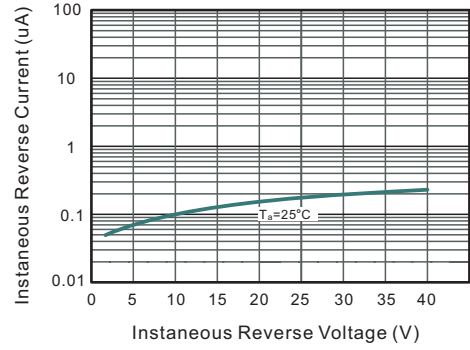

**Fig.3 Typical Forward Characteristic**

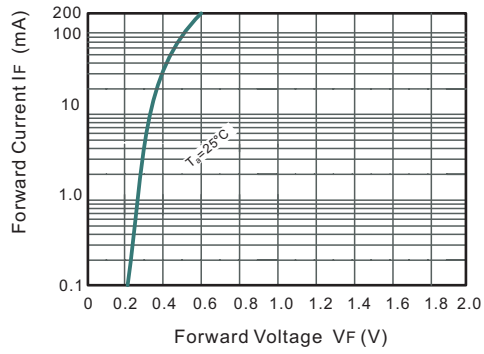

**Fig.4 Typical Junction Capacitance**

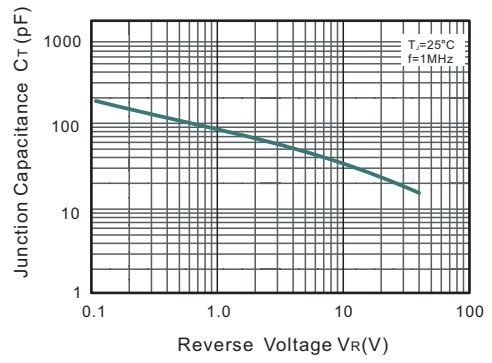

**PACKAGE OUTLINE**

Plastic surface mounted package; 2 leads

**SOD-523**

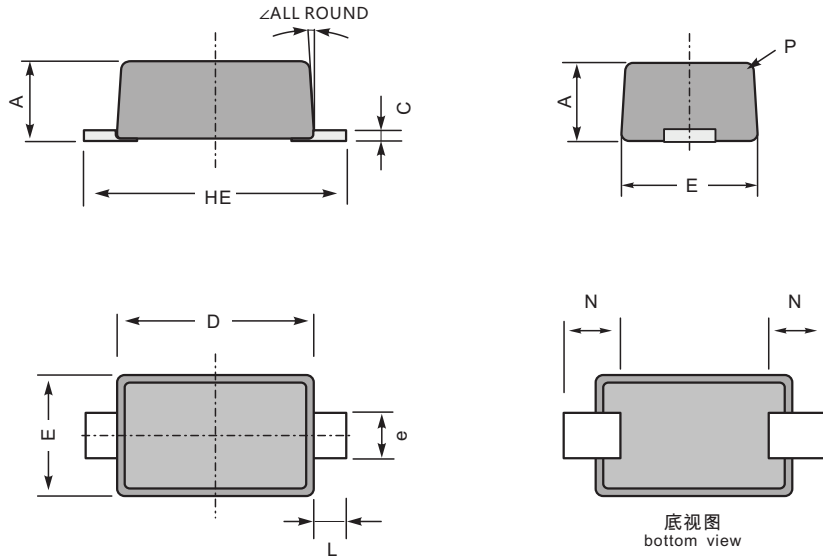

UNIT		A	e	C	D	E	HE	N	L	P	∠
mm	max	0.77	0.35	0.15	1.30	0.99	1.70	0.35 ref	0.2 ref	R0.1 ALL ROUND	10° ±1°
	min	0.51	0.25	0.08	1.10	0.75	1.50				
mil	max	30	14	6	51	39	67	14 ref	8.0 ref	R4.0 ALL ROUND	
	min	20	10	3	43	30	59				

**The recommended mounting pad size**

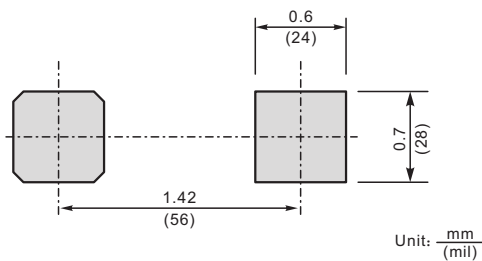

## X-ON Electronics

Largest Supplier of Electrical and Electronic Components

*Click to view similar products for [Schottky Diodes & Rectifiers](#) category:*

*Click to view products by [Yongyutai Electronics](#) manufacturer:*

Other Similar products are found below :

[MA4E2039](#) [MA4E2508M-1112](#) [MBR1545CT](#) [MMBD301M3T5G](#) [RB160M-50TR](#) [D83C](#) [BAS16E6433HTMA1](#) [BAT 54-02LRH E6327](#)  
[NRVBAF360T3G](#) [NSR05F40QNXT5G](#) [NTE555](#) [JANS1N6640](#) [SK310-T](#) [SK34B-TP](#) [SS3003CH-TL-E](#) [GA01SHT18](#)  
[CRS10I30A\(TE85L,QM](#) [MA4E2501L-1290](#) [MBRA140TRPBF](#) [MBRB30H30CT-1G](#) [BAT 15-04R E6152](#) [JANTX1N5712-1](#) [DMJ3940-000](#)  
[SB007-03C-TB-E](#) [SK33B-TP](#) [NRVBB20100CTT4G](#) [NRVBM120LT1G](#) [NTSB30U100CT-1G](#) [VS-6CWQ10FNHM3](#) [CRG04\(T5L,TEMQ\)](#)  
[ACDBA1100LR-HF](#) [ACDBA1200-HF](#) [ACDBA240-HF](#) [ACDBA3100-HF](#) [CDBQC0530L-HF](#) [CDBQC0240LR-HF](#) [ACDBA260LR-HF](#)  
[ACDBA1100-HF](#) [MA4E2502L-1246](#) [10BQ015-M3/5BT](#) [NRVBM120ET1G](#) [CRS08TE85LQM](#) [PMAD1108-LF](#) [B120Q-13-F](#) [1N5819T-G](#)  
[B0530WSQ-7-F](#) [PDS1040Q-13](#) [B160BQ-13-F](#) [SDM05U20CSP-7](#) [B140S1F-7](#)