

300mA Low Power LDO

DESCRIPTION

The HT73XX-1 series is a set of three-terminal low power high voltage regulators implemented in CMOS technology. They allow input voltages as high as 24V. The series features extremely low quiescent current which is typically 2 μ A. They are available with several fixed output voltages ranging from 1.8V to 5.0V. CMOS technology ensures low voltage drop and low quiescent current. Although designed primarily as fixed voltage regulators, these devices can be used with external components to obtain variable voltages and currents.

FEATURES:

- ※ Output voltage accuracy: tolerance $\pm 2\%$
- ※ Ultra low quiescent current: 2 μ A(typ.)
- ※ High input voltage (up to 24V)
- ※ Maximum output current: 300mA
- ※ Low voltage drop
- ※ Low power consumption

Applications:

- Battery-powered equipment
- Communication equipment
- Audio/Video equipment

Absolute Maximum ratings

Parameter	Symbol	Value	Unit
Supply Voltage	V_i	-0.3 ~ +24	V
Power Dissipation	PD	500	mW
Thermal Resistance	θ_{JA}	200	$^{\circ}\text{C}/\text{W}$
Operating Junction Temperature Range	TOPR	-30~+85	$^{\circ}\text{C}$
Storage Temperature Range	TSTG	-50~+125	$^{\circ}\text{C}$

Note: These are stress ratings only. Stresses exceeding the range specified under “Absolute Maximum Ratings” may cause substantial damage to the device. Functional operation of this device at other conditions beyond those listed in the specification is not implied and prolonged exposure to extreme conditions may affect device reliability.

BLOCK DIAGRAM :

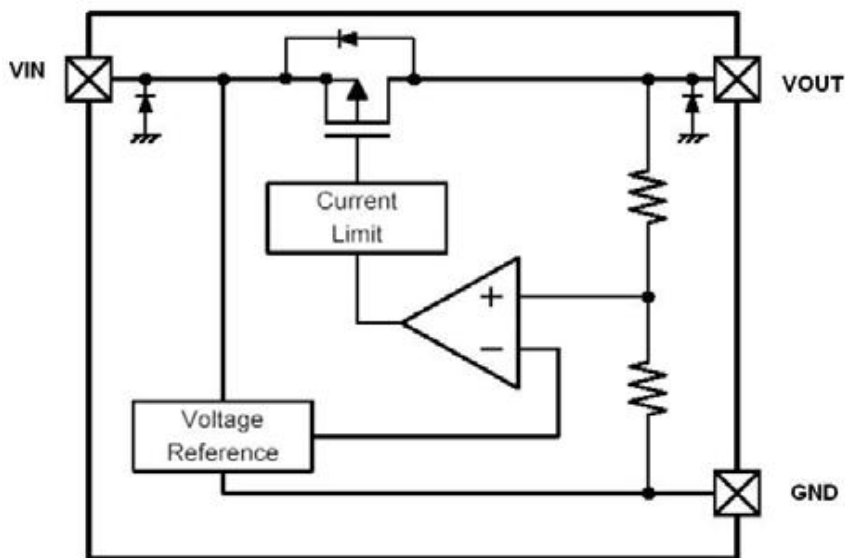

*Diodes inside the circuit are an ESD protection diode and a parasitic diode.

Pin Assignment:

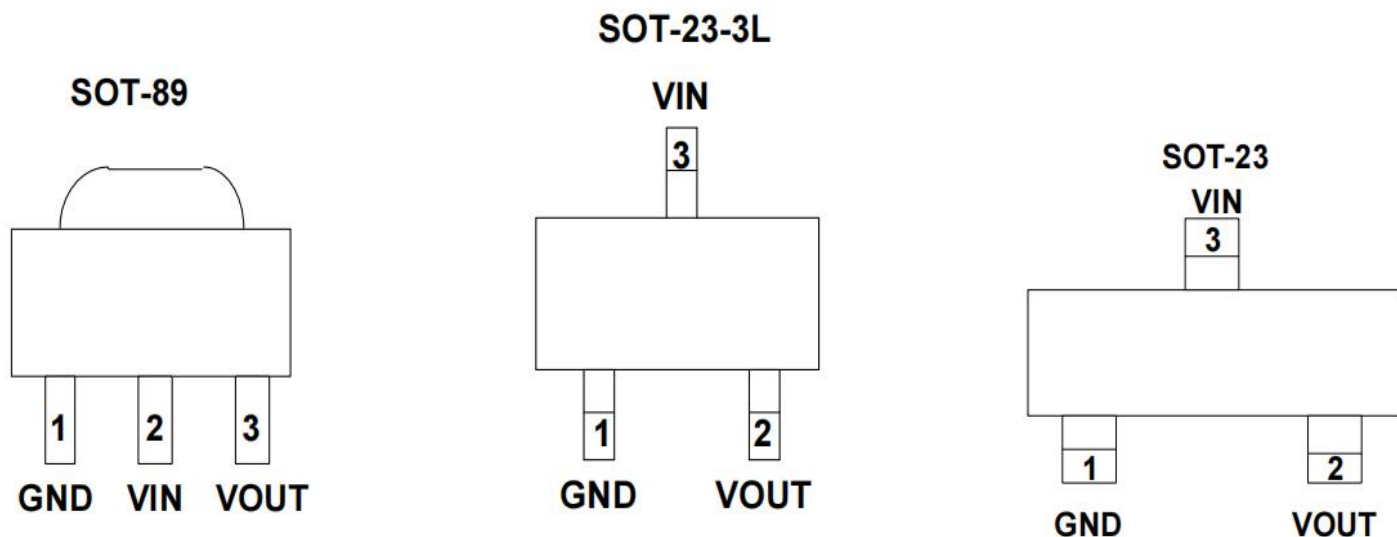

Pin number			Pin	Explain
SOT-89	SOT-23-3L	SOT-23		
1	1	1	GND	ground terminal
2	3	3	VIN	Power terminal
3	2	2	VOUT	output end

ELECTRICAL CHARACTERISTICS (TA=25°C, unless otherwise specified)
HT7325-1 +2.5V Output Type

Parameter	Symbol	Test Condition		Min	Typ	Max	Unit
		Conditions	VIN				
Output Voltage	VOUT	IOUT=40mA	5.5V	2.450	2.500	2.550	V
Output Current	IOUT		5.5V	180	250		mA
Load Regulation	ΔVOUT	1mA≤IOUT≤60mA	5.5V		45	90	mV
Voltage Drop(Note)	VDIF	IOUT=40mA, ΔVOUT=2%			100		mV
Line Regulation	$\frac{V_{OUT}}{V_{IN} \cdot V_{OUT}}$	3.5V≤VIN≤12V IOUT=40mA			0.2		%/V
Input Voltage	VIN					15	V
Temperature Coefficient	$\frac{V_{OUT}}{Ta}$	IOUT=40mA , -40°C≤TA≤85°C	5.5V		±0.5		mV/°C
Current Consumption	ISS	No load	5.5V		2.5	3.0	uA

Notes:

1. Dropout voltage is defined as the input voltage minus the output voltage that produces a 2% change in the output voltage from the value at VIN = VOUT+1V with a fixed load.
2. change in the output voltage from the value at VIN = VOUT+1V with a fixed load.

ELECTRICAL CHARACTERISTICS (TA=25°C, unless otherwise specified)
HT7328-1 +2.8V Output Type

Parameter	Symbol	Test Condition		Min	Typ	Max	Unit
		Conditions	VIN				
Output Voltage	VOUT	IOUT=40mA	5.8V	2.774	2.800	2.856	V
Output Current	IOUT		5.8V	200	250		mA
Load Regulation	ΔVOUT	1mA≤IOUT≤60mA	5.8V		45	90	mV
Voltage Drop(Note)	VDIF	OUT=40mA, ΔVOUT=2%			100		mV
Line Regulation	$\frac{V_{OUT}}{V_{IN} \cdot V_{OUT}}$	3.8V≤VIN≤12V IOUT=40mA			0.2		%/V
Input Voltage	VIN					15	V
Temperature Coefficient	$\frac{V_{OUT}}{Ta}$	IOUT=40mA , -40°C≤TA≤85°C	5.8V		±0.5		mV/°C
Current Consumption	ISS	No load	5.8V		2.5	3.0	uA

Notes:

1. Dropout voltage is defined as the input voltage minus the output voltage that produces a 2% change in the output voltage from the value at VIN = VOUT+1V with a fixed load.
2. change in the output voltage from the value at VIN = VOUT+1V with a fixed load.

ELECTRICAL CHARACTERISTICS (TA=25°C, unless otherwise specified)
HT7330-1 +3.0V Output Type

Parameter	Symbol	Test Condition		Min	Typ	Max	Unit
		Conditions	VIN				
Output Voltage	VOUT	IOUT=40mA	6.0V	2.94	3.00	3.06	V
Output Current	IOUT		6.0V	250			mA
Load Regulation	ΔVOUT	1mA≤IOUT≤80mA	6.0V		45	90	mV
Voltage Drop(Note)	VDIF	IOUT=40mA, ΔVOUT=2%			100		mV
Line Regulation	$\frac{V_{OUT}}{V_{IN} \cdot V_{OUT}}$	4.0V≤VIN≤12V IOUT=40mA			0.2		%/V
Input Voltage	VIN					15	V
Temperature Coefficient	$\frac{V_{OUT}}{Ta}$	IOUT=40mA , -40°C≤TA≤85°C	6.0V		±0.5		mV/°C
Current Consumption	ISS	No load	6.0V		2.5	3.0	uA

Notes:

1. Dropout voltage is defined as the input voltage minus the output voltage that produces a 2% change in the output voltage from the value at VIN = VOUT+1V with a fixed load.
2. change in the output voltage from the value at VIN = VOUT+1V with a fixed load.

ELECTRICAL CHARACTERISTICS (TA=25°C, unless otherwise specified)
HT7333-1 +3.3V Output Type

Parameter	Symbol	Test Condition		Min	Typ	Max	Unit
		Conditions	VIN				
Output Voltage	VOUT	IOUT=40mA	6.3V	3.234	3.300	3.366	V
Output Current	IOUT		6.3V	250			mA
Load Regulation	ΔVOUT	1mA≤IOUT≤80mA	6.3V		45	90	mV
Voltage Drop(Note)	VDIF	IOUT=40mA, ΔVOUT=2%			100		mV
Line Regulation	$\frac{V_{OUT}}{V_{IN} \cdot V_{OUT}}$	4.3V≤VIN≤12V IOUT=40mA			0.2		%/V
Input Voltage	VIN					15	V
Temperature Coefficient	$\frac{V_{OUT}}{Ta}$	IOUT=40mA , -40°C≤TA≤85°C	6.3V		±0.5		mV/°C
Current Consumption	ISS	No load	6.3V		2.5	3.0	uA

Notes:

1. Dropout voltage is defined as the input voltage minus the output voltage that produces a 2% change in the output voltage from the value at VIN = VOUT+1V with a fixed load.
2. change in the output voltage from the value at VIN = VOUT+1V with a fixed load.

ELECTRICAL CHARACTERISTICS (TA=25°C, unless otherwise specified)
HT7336-1 +3.6V Output Type

Parameter	Symbol	Test Condition		Min	Typ	Max	Unit
		Conditions	VIN				
Output Voltage	VOUT	IOUT=40mA	6.6V	3.528	3.600	3.672	V
Output Current	IOUT		6.6V	250			mA
Load Regulation	ΔVOUT	1mA≤IOUT≤80mA	6.6V		45	90	mV
Voltage Drop(Note)	VDIF	IOUT=40mA, ΔVOUT=2%			80		mV
Line Regulation	$\frac{V_{OUT}}{V_{IN} \cdot V_{OUT}}$	4.6V≤VIN≤12V IOUT=40mA			0.2		%/V
Input Voltage	VIN					15	V
Temperature Coefficient	$\frac{V_{OUT}}{Ta}$	IOUT=40mA , -40°C≤TA≤85°C	6.6V		±0.5		mV/°C
Current Consumption	ISS	No load	6.6V		2.5	3.0	uA

Notes:

1. Dropout voltage is defined as the input voltage minus the output voltage that produces a 2% change in the output voltage from the value at VIN = VOUT+1V with a fixed load.
2. change in the output voltage from the value at VIN = VOUT+1V with a fixed load.

ELECTRICAL CHARACTERISTICS (TA=25°C, unless otherwise specified)
HT7340-1 +4.0V Output Type

Parameter	Symbol	Test Condition		Min	Typ	Max	Unit
		Conditions	VIN				
Output Voltage	VOUT	IOUT=40mA	7.0V	3.920	4.000	4.080	V
Output Current	IOUT		7.0V	250			mA
Load Regulation	ΔVOUT	1mA≤IOUT≤80mA	7.0V		45	90	mV
Voltage Drop(Note)	VDIF	IOUT=40mA, ΔVOUT=2%			80		mV
Line Regulation	$\frac{V_{OUT}}{V_{IN} V_{OUT}}$	5.0V≤VIN≤12V IOUT=40mA			0.2		%/V
Input Voltage	VIN					15	V
Temperature Coefficient	$\frac{V_{OUT}}{Ta}$	IOUT=40mA , -40°C≤TA≤85°C	7.0V		±0.5		mV/°C
Current Consumption	ISS	No load	7.0V		2.5	3.0	uA

Notes:

1. Dropout voltage is defined as the input voltage minus the output voltage that produces a 2% change in the output voltage from the value at VIN = VOUT+1V with a fixed load.
2. change in the output voltage from the value at VIN = VOUT+1V with a fixed load.

ELECTRICAL CHARACTERISTICS (TA=25°C, unless otherwise specified)
HT7344-1 +4.4V Output Type

Parameter	Symbol	Test Condition		Min	Typ	Max	Unit
		Conditions	VIN				
Output Voltage	VOUT	IOUT=40mA	7.4V	4.312	4.400	4.488	V
Output Current	IOUT		7.4V	250			mA
Load Regulation	ΔVOUT	1mA≤IOUT≤80mA	7.4V		45	90	mV
Voltage Drop(Note)	VDIF	IOUT=40mA, ΔVOUT=2%			80		mV
Line Regulation	$\frac{V_{OUT}}{V_{IN} \cdot V_{OUT}}$	5.4V≤VIN≤12V IOUT=40mA			0.2		%/V
Input Voltage	VIN					15	V
Temperature Coefficient	$\frac{V_{OUT}}{Ta}$	IOUT=40mA , -40°C≤TA≤85°C	7.4V		±0.5		mV/°C
Current Consumption	ISS	No load	7.4V		2.5	3.0	uA

Notes:

1. Dropout voltage is defined as the input voltage minus the output voltage that produces a 2% change in the output voltage from the value at VIN = VOUT+1V with a fixed load.
2. change in the output voltage from the value at VIN = VOUT+1V with a fixed load.

ELECTRICAL CHARACTERISTICS (TA=25°C, unless otherwise specified)

HT7350-1 +5.0V Output Type

Parameter	Symbol	Test Condition		Min	Typ	Max	Unit
		Conditions	VIN				
Output Voltage	VOUT	IOUT=40mA	8.0V	4.90	5.00	5.10	V
Output Current	IOUT		8.0V	250			mA
Load Regulation	ΔVOUT	1mA≤IOUT≤80mA	8.0V		45	90	mV
Voltage Drop(Note)	VDIF	OUT=40mA, ΔVOUT=2%			80		mV
Line Regulation	$\frac{V_{OUT}}{V_{IN} V_{OUT}}$	6.0V≤VIN≤12V IOUT=40mA			0.2		%/V
Input Voltage	VIN					15	V
Temperature Coefficient	$\frac{V_{OUT}}{Ta}$	IOUT=40mA , -40°C≤TA≤85°C	8.0V		±0.5		mV/°C
Current Consumption	ISS	No load	8.0V		2.5	3.0	uA

Notes:

1. Dropout voltage is defined as the input voltage minus the output voltage that produces a 2% change in the output voltage from the value at VIN = VOUT+1V with a fixed load.
2. change in the output voltage from the value at VIN = VOUT+1V with a fixed load.

TYPICAL APPLICATION CIRCUIT :

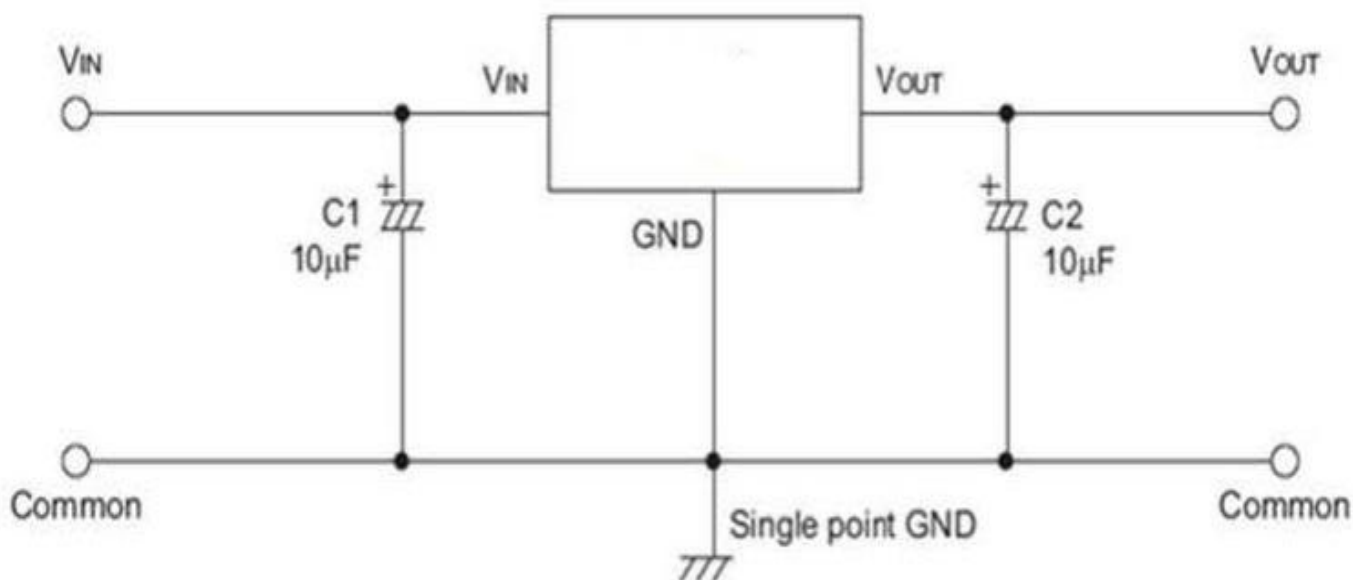

X-ON Electronics

Largest Supplier of Electrical and Electronic Components

Click to view similar products for [Linear Voltage Regulators](#) category:

Click to view products by [Yongyutai Electronics](#) manufacturer:

Other Similar products are found below :

[LV5684PVD-XH](#) [MCDTSA6-2R](#) [L7815ACV-DG](#) [LV56801P-E](#) [UA7805CKC](#) [714954EB](#) [ZMR500QFTA](#) [BA033LBSG2-TR](#)
[NCV78M05ABDTRKG](#) [LV5680P-E](#) [L79M05T-E](#) [L78LR05D-MA-E](#) [NCV317MBTG](#) [NTE7227](#) [MP2018GZD-33-P](#) [MP2018GZD-5-P](#)
[LV5680NPVC-XH](#) [ZTS6538SE](#) [UA78L09CLP](#) [UA78L09CLPR](#) [CAT6221-PPTD-GT3](#) [MC78M09CDTRK](#) [NCV51190MNTAG](#)
[BL1118CS8TR1833](#) [BL8077CKETR33](#) [BL9153-33CC3TR](#) [BL9161G-28BADRN](#) [BRCO7530MMC](#) [CJ7815B-TFN-ARG](#) [LM317C](#)
[GM7333K](#) [GM7350K](#) [XC6206P332MR](#) [HT7533](#) [LM7912S/TR](#) [LT1764S/TR](#) [LM7805T](#) [LM338T](#) [LM1117IMP-3.3/TR](#) [HT1117AM-3.3](#)
[HT7550S](#) [AMS1117-3.3](#) [HT7150S](#) [78L12](#) [HT7550](#) [HT7533-1](#) [HXY6206I-2.5](#) [HT7133](#) [HT7533S](#) [662K](#)