

## TRANSIENT VOLTAGE SUPPRESSOR

### FEATURE

- ✧ Plastic package.
- ✧ Glass passivated chip junction in SMB Package
- ✧ Excellent clamping capability.
- ✧ Low zener impedance.
- ✧ 600W peak pulse power capability on 10/1000µs waveform.
- ✧ Typical IR less than 1µA above 13V.
- ✧ Fast response time: typically less than 1.0ps from 0 Volts to BV min.
- ✧ High temperature soldering guaranteed: 265°C/10 seconds

### MECHANICAL DATE

- ✧ Case: JEDEC SMB Molded Plastic.
- ✧ Terminals: Axial leads, solderable per MIL-STD-750, Method 2026.
- ✧ Polarity: Color band denoted cathode except bidirectional.
- ✧ Mounting Position: Any.

### MAXIMUM RATINGS AND CHARACTERISTICS

Ratings at 25c ambient temperature unless otherwise specified.

RATING	SYMBOL	VALUE	UNITS
Peak Pulse Power Dissipation on 10/1000us waveform (Notel, Fig. 1).	P <sub>PPM</sub>	Minimum 600	Watts
Peak Pulse Current of on 10/1000us waveform. (Notel, Fig. 3)	I <sub>PPM</sub>	See Table	Amps
Steady State Power Dissipation at TL =75°C, Lead lengths. 375", (9.5mm) (Fig. 5).	P <sub>M(AV)</sub>	5.0	Watts
Peak Forward Surge Current, 8.3ms Single Half Sine-Wave Superimposed on Rated Load, (JEDEC Method) (Note 2, Fig. 6).	I <sub>FSM</sub>	100	Amps
Operating junction and Storage Temperature Range.	T <sub>J</sub> , T <sub>STG</sub>	-55 to +150	°C

Notes:

1. Non-repetitive current pulse, per Fig. 3 and derated above TA = 25°C per Fig. 2.
2. 8.3ms single half sine-wave, or equivalent square wave, Duty cycle = 4 pulses per minutes maximum.

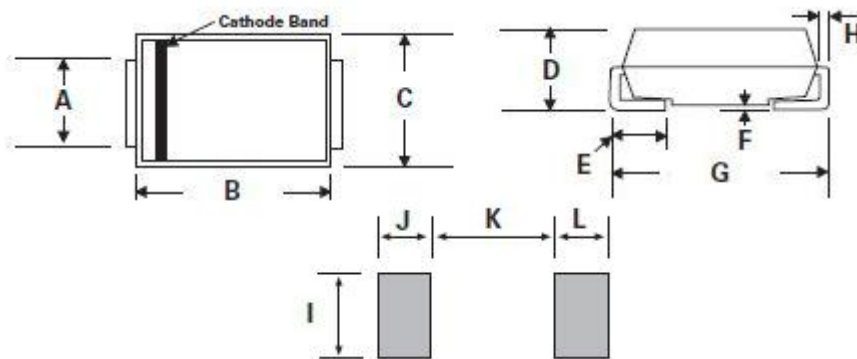

Item	Millimeters		Inches	
	Min.	Max.	Min.	Max.
A	1.95	2.2	0.077	0.086
B	4.06	4.57	0.16	0.18
C	3.3	3.94	0.13	0.155
D	2.13	2.44	0.084	0.096
E	0.76	1.52	0.03	0.06
F	-	0.203	-	0.008
G	5.21	5.59	0.205	0.22
H	0.152	0.305	0.006	0.012
I	2.26	-	0.089	-
J	2.16	-	0.085	-
K	-	2.74	-	0.107
L	2.16	-	0.085	-

## ELECTRICAL CHARACTERISTICS

Part Number	Marking	Reverse Stand-Off Voltage	Breakdown Voltage NIN.@IT	Breakdown Voltage MAX.@IT	Reverse Leakage @VRWM	Test Current	Peak Pulse Current	Maximum Clamping Voltage
		VR(V)	VBL(V)	VBH(V)	IR(uA)	IT(mA)	IPP(A)	VCH(V)
KSMBJ6.8CA-E3/52	AK	6.8	7.22	7.98	500	10	53.6	11.2

**RATINGS AND CHARACTERISTIC CURVES** (TA=25°C unless otherwise noted)

**Figure 1 - Peak Pulse Power Rating Curve**

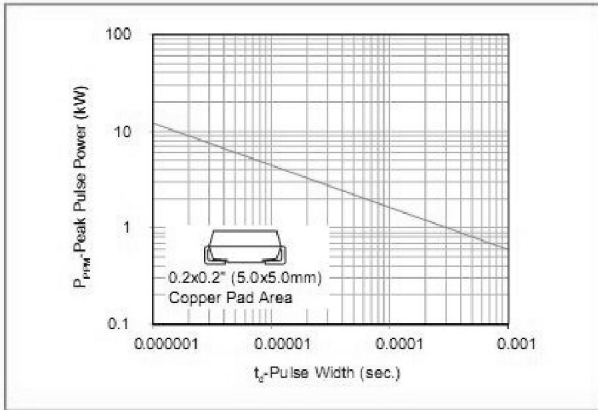

**Figure 2 - Pulse Derating Curve**

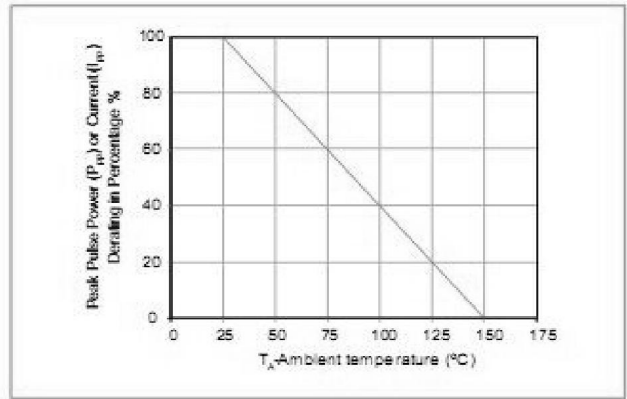

**Figure 3 - Pulse Waveform**

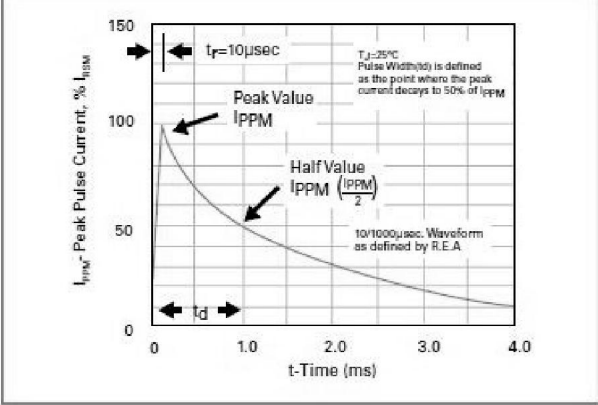

**Figure 4 - Typical Junction Capacitance Uni-Directional**

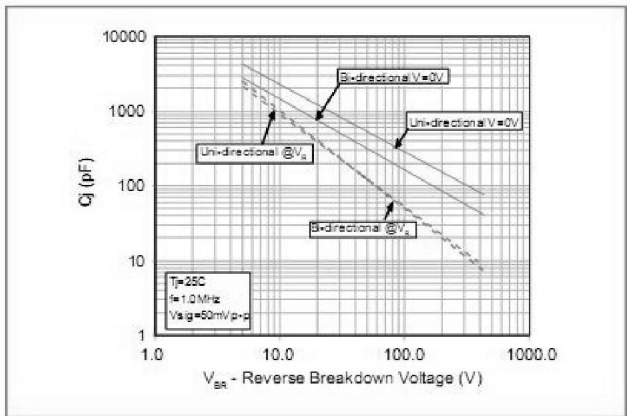

**Figure 5 - Steady State Power Dissipation Derating Curve**

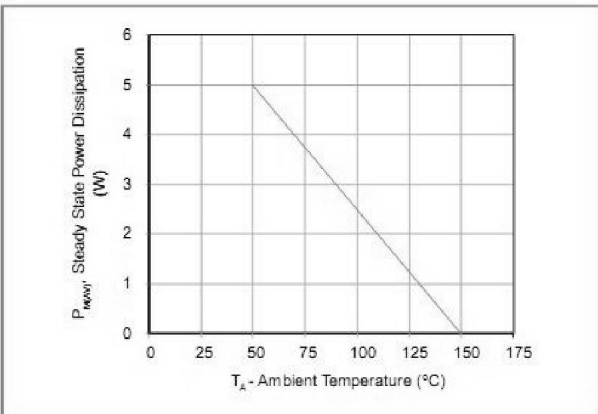

**Figure 6 - Maximum Non-Repetitive Forward Surge Current Uni-Directional Only**

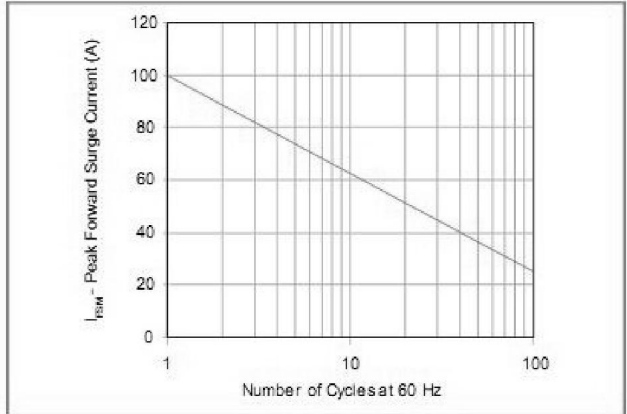

## X-ON Electronics

Largest Supplier of Electrical and Electronic Components

*Click to view similar products for [ESD Suppressors / TVS Diodes](#) category:*

*Click to view products by [Yongyutai Electronics](#) manufacturer:*

Other Similar products are found below :

[60KS200C](#) [D18V0L1B2LP-7B](#) [D5V0F4U5P5-7](#) [NTE4902](#) [P4KE27CA](#) [P6KE11CA](#) [P6KE8.2A](#) [SA60CA](#) [SA64CA](#) [SMBJ12CATR](#)  
[SMBJ33CATR](#) [SMBJ6.5A](#) [SMBJ8.0A](#) [ESD101-B1-02ELS](#) [E6327](#) [ESD112-B1-02EL](#) [E6327](#) [ESD7451N2T5G](#) [19180-510](#) [CPDT-5V0USP-](#)  
[HF](#) [3.0SMCJ33CA-F](#) [3.0SMCJ36A-F](#) [HSPC16701B02TP](#) [JANTX1N6126A](#) [D3V3Q1B2DLP3-7](#) [D55V0M1B2WS-7](#) [SCM1293A-04SO](#)  
[ESD200-B1-CSP0201](#) [E6327](#) [SM12-7](#) [CEN955 W/DATA](#) [VESD12A1A-HD1-GS08](#) [CPDQC5V0-HF](#) [D1213A-01LP4-7B](#) [ESD101-B1-02EL](#)  
[E6327](#) [AOZ8808DI-03](#) [5KP15A](#) [5KP48A](#) [5KP90A](#) [ESD3V3D7-TP](#) [15KPA36A-LF](#) [P4KE56CA](#) [P4KE68A](#) [P4KE91CATR](#) [P6KE120A](#)  
[P6KE13CA](#) [P6KE43CA](#) [P6KE6.8CA](#) [P6KE8.2](#) [P6SMBJ20CA](#) [JANTX1N6072A](#) [SR2835ESKG](#) [SA90CA](#)