

SOT-23 Plastic-Encapsulate Transistors

S8550 TRANSISTOR (PNP)

FEATURES

Complimentary to S8050
 Collector current: $I_C=0.5A$

MARKING: 2TY

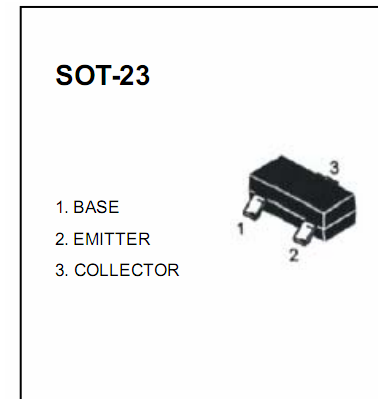

MAXIMUM RATINGS (TA=25°C unless otherwise noted)

Symbol (符号)	Parameter (参数名称)	Value (额定值)	Units (单位)
VCBO	Collector-Base Voltage (集电极-基极电压)	-40	V
VCEO	Collector-Emitter Voltage (集电极-发射极电压)	-25	V
VEBO	Emitter-Base Voltage (发射极-基极电压)	-5	V
IC	Collector Current -Continuous (集电极电流)	-0.5	A
PC	Collector Power Dissipation (耗散功率)	0.3	W
Tj	Junction Temperature (结温)	150	°C
Tstg	Storage Temperature (储存温度)	-55-150	°C

ELECTRICAL CHARACTERISTICS (Tamb=25°C unless otherwise specified)

Parameter (参数名称)	Symbol (符号)	Test conditions (测试条件)	MIN (最小值)	TYP (典型值)	MAX (最大值)	UNIT (单位)
Collector-base breakdown voltage 集电极-基极击穿电压	V(BR)CBO	IC= -100μA, IE=0	-40			V
Collector-emitter breakdown voltage 集电极-发射极击穿电压	V(BR)CEO	IC= -1mA, IB=0	-25			V
Emitter-base breakdown voltage 发射极-基极击穿电压	V(BR)EBO	IE=-100μA, IC=0	-5			V
Collector cut-off current 集电极-基极截止电流	ICBO	VCB=-30 V, IE=0			-1	μ A
Collector cut-off current 集电极-发射极截止电流	ICEO	VCE=-25V, IB=0			-10	μ A
Emitter cut-off current 发射极-基极截止电流	IEBO	VEB=-5V, IC=0			-1	μ A
DC current gain 直流电流增益	hFE	VCE=-1V, IC= -50mA	80		400	
Collector-emitter saturation voltage 集电极-发射极饱和压降	VCE(sat)	IC=-500mA, IB= -50mA			-0.5	V
Base-emitter saturation voltage 发射极-基极饱和压降	VBE(sat)	IC=-500mA, IB= -50mA			-1.2	V

CLASSIFICATION OF hFE

Range	80-100	100-200	200-400	400-600

Typical Characteristics

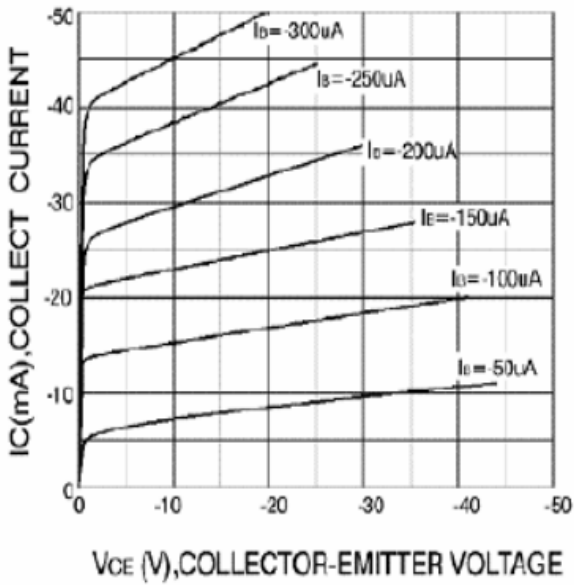

Static Characteristic

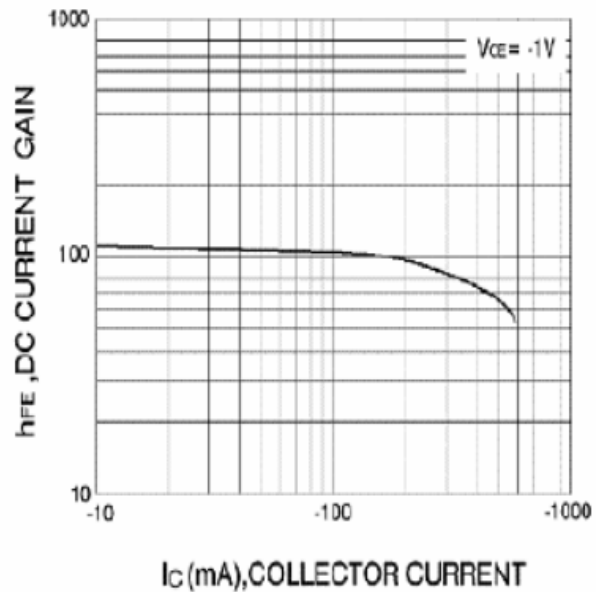

DC current Gain

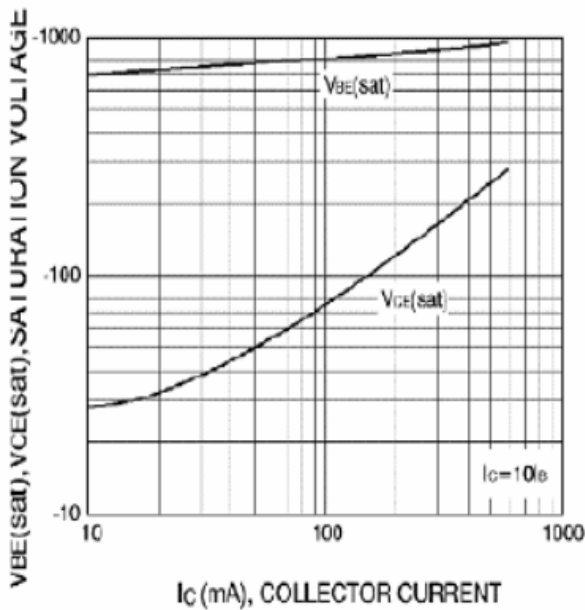

Base-Emitter Saturation Voltage
Collector-Emitter Saturation Voltage

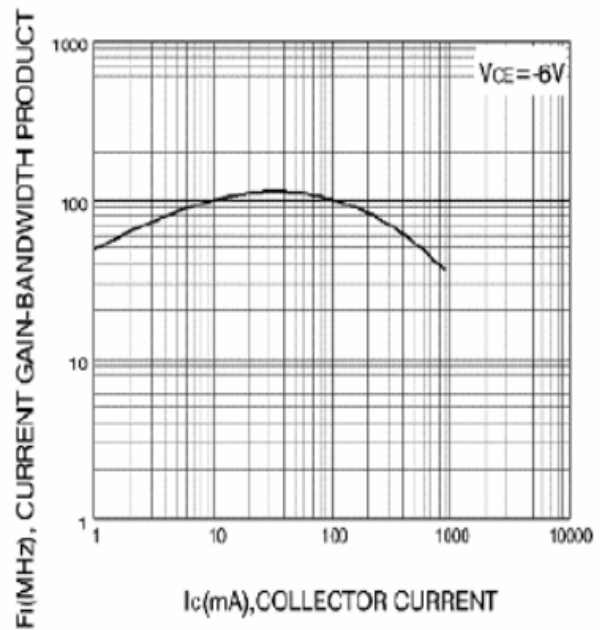

Current Gain Bandwidth Product

X-ON Electronics

Largest Supplier of Electrical and Electronic Components

Click to view similar products for [Bipolar Transistors - BJT category](#):

Click to view products by [Yongyutai Electronics manufacturer](#):

Other Similar products are found below :

[619691C](#) [MCH4017-TL-H](#) [MMBT-2369-TR](#) [BC546/116](#) [BC557/116](#) [BSW67A](#) [NJVMJD148T4G](#) [NTE123AP-10](#) [NTE153MCP](#) [NTE16](#)
[NTE195A](#) [NTE92](#) [2N4401-A](#) [2N6728](#) [2SA1419T-TD-H](#) [2SA2126-E](#) [2SB1204S-TL-E](#) [2SC2712S-GR,LF](#) [SP000011176](#) [2N2907A](#) [2N3904-](#)
[NS](#) [2N5769](#) [2SC2412KT146S](#) [CPH6501-TL-E](#) [MCH4021-TL-E](#) [MJE340](#) [Jantx2N5416](#) [US6T6TR](#) [NJL0281DG](#) [732314D](#) [CPH3121-TL-E](#)
[CPH6021-TL-H](#) [873787E](#) [IMZ2AT108](#) [MMST8098T146](#) [UMX21NTR](#) [MCH6102-TL-E](#) [NJL0302DG](#) [30A02MH-TL-E](#) [NTE13](#) [NTE26](#)
[NTE282](#) [NTE323](#) [NTE350](#) [NTE81](#) [STX83003-AP](#) [JANTX2N2920L](#) [JANSR2N2222AUB](#) [CMLT3946EG TR](#) [2SA1371D-AE](#)