

N-Channel 30-V(D-S) MOSFET

V(BR)DSS	RDS(on)MAX	ID
30 V	65mΩ@10V	3.5A
	90mΩ@4.5V	

FEATURE

- ※ TrenchFET Power MOSFET

APPLICATION

- ※ Load Switch for Portable Devices
- ※ DC/DC Converter

MARKING

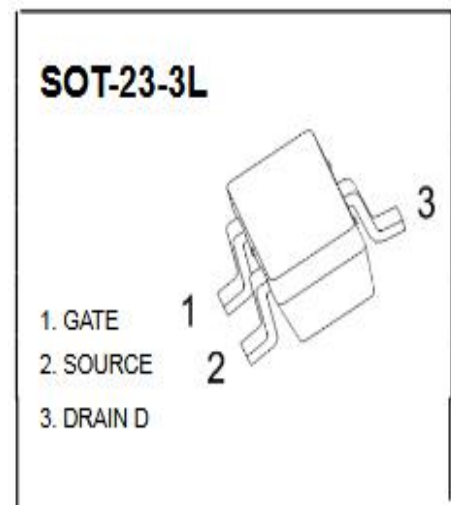
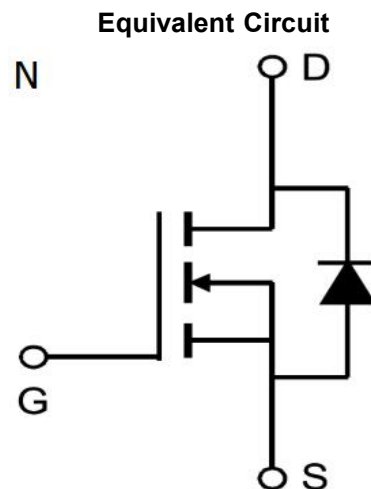
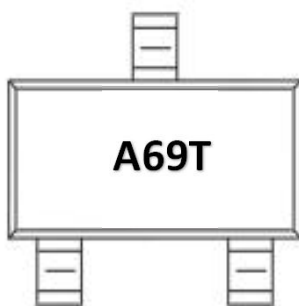

Maximum ratings (Ta=25°C unless otherwise noted)

Parameter	Symbol	Value	Unit
Drain-Source Voltage	VDS	30	V
Gate-Source Voltage	VGS	±20	
Continuous Drain Current	ID	3.5	A
Pulsed Diode Current	IDM	20	
Continuous Source-Drain Current(Diode Conduction)	IS	0.8	
Power Dissipation	PD	0.75	W
Thermal Resistance from Junction to Ambient (t≤5s)	RθJA	150	°C/W
Operating Junction	TJ	150	°C
Storage Temperature	TSTG	-55~+150	°C

MOSFET ELECTRICAL CHARACTERISTICS
Static Electrical Characteristics (Ta = 25 °C Unless Otherwise Noted)

Parameter	Symbol	Test Condition	Min	Typ	Max	Unit
Static						
Drain-source breakdown voltage	V(BR)DSS	VGS = 0V, ID = 250μA	30			V
Gate-source threshold voltage	VGS(th)	VDS = VGS, ID = 250μA	1		3	V
Gate-source leakage	IGSS	VDS = 0V, VGS = ±20V			±100	nA
Zero gate voltage drain current	IDSS	VDS = 30V, VGS = 0V			1	μA
Drain-source on-state resistancea	RDS(on)	VGS = 10V, ID = 3.5A		40	65	mΩ
		VGS = 4.5V, ID = 2.8A		53	90	mΩ
Forward transconductancea	gfs	VDS = 4.5V, ID = 3.5A		7		S
Diode forward voltage	VSD	IS = 1.25A, VGS = 0V		0.8	1.3	V
Dynamic						
Input capacitance	Ciss	VDS = 15V, VGS = 0V, f = 1MHz		305		pF
Output capacitance	Coss			65		pF
Reverse transfer capacitanceb	Crss			29		pF
Total gate charge	Qg	VDS = 18V, VGS = 4.5V, ID = 3.5A		3	4.5	nC
Gate-source charge	Qgs			1.6		nC
Gate-drain charge	Qgd			0.6		nC
Gate resistance	Rg	f = 1MHz		5		Ω
Switchingb						
Turn-on delay time	td(on)	VDD = 10V RL = 10Ω, ID ≈ 3A, VGEN = 4.5V, Rg = 6Ω		7	11	ns
Rise time	tr			12	18	ns
Turn-off delay time	td(off)			14	25	ns
Fall time	tf			6	10	ns
Drain-source body diode characteristics						
Continuous Source-Drain Diode Current	IS	Tc = 25°C			1.3	A
Pulsed Diode forward Curren	ISM				20	A

Note :

1. Repetitive Rating : Pulse width limited by maximum junction temperature.
2. Surface Mounted on FR4 Board, t < 5 sec.
3. Pulse Test : Pulse Width ≤ 300μs, Duty Cycle ≤ 2%.
4. Guaranteed by design, not subject to production testing.

SOT-23-3L PACKAGE OUTLINE DIMENSIONS

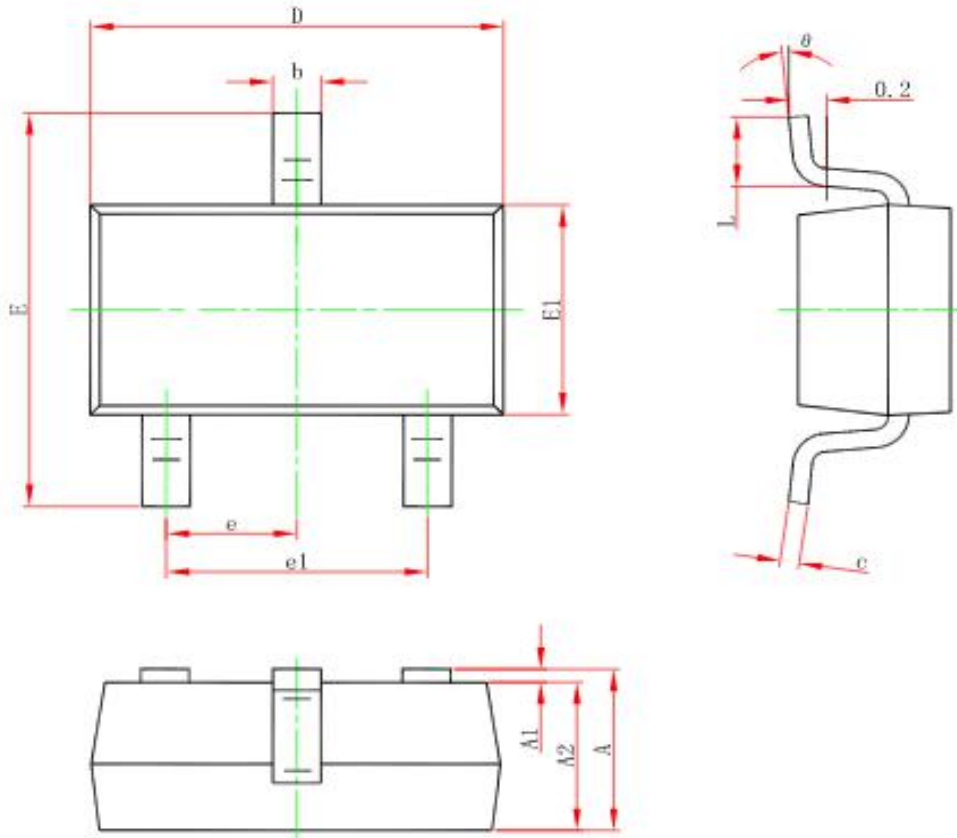

Symbol	Dimensions In Millimeters		Dimensions In Inches	
	Min.	Max.	Min.	Max.
A	1.050	1.250	0.041	0.049
A1	0.000	0.100	0.000	0.004
A2	1.050	1.150	0.041	0.045
b	0.300	0.500	0.012	0.020
c	0.100	0.200	0.004	0.008
D	2.820	3.020	0.111	0.119
E1	1.500	1.700	0.059	0.067
E	2.650	2.950	0.104	0.116
e	0.950(BSC)		0.037(BSC)	
e1	1.800	2.000	0.071	0.079
L	0.300	0.600	0.012	0.024
theta	0°	8°	0°	8°

X-ON Electronics

Largest Supplier of Electrical and Electronic Components

Click to view similar products for [MOSFET](#) category:

Click to view products by [Yongyutai Electronics](#) manufacturer:

Other Similar products are found below :

[IRFD120](#) [IRFF430](#) [JANTX2N5237](#) [2SK2267\(Q\)](#) [BUK455-60A/B](#) [TK100A10N1,S4X\(S](#) [MIC4420CM-TR](#) [VN1206L](#) [NDP4060](#) [SI4482DY](#)
[IRS2092STRPBF-EL](#) [IPS70R2K0CEAKMA1](#) [SQM120N06-3M5L-GE3](#) [TK31J60W5,S1VQ\(O](#) [TK31J60W,S1VQ\(O](#) [TK16J60W,S1VQ\(O](#)
[2SK2614\(TE16L1,Q\)](#) [DMN1017UCP3-7](#) [EFC2J004NUZTDG](#) [P85W28HP2F-7071](#) [NTE2384](#) [DMC2700UDMQ-7](#) [DMN2080UCB4-7](#)
[DMN61D9UWQ-13](#) [US6M2GTR](#) [DMN31D5UDJ-7](#) [DMP22D4UFO-7B](#) [IPS60R3K4CEAKMA1](#) [DMN1006UCA6-7](#) [DMN16M9UCA6-7](#)
[STF5N65M6](#) [IRF40H233XTMA1](#) [STU5N65M6](#) [DMN6022SSD-13](#) [DMN13M9UCA6-7](#) [DMTH10H4M6SPS-13](#) [IPS60R360PFD7SAKMA1](#)
[DMN2990UFB-7B](#) [SSM3K35CT,L3F](#) [IPLK60R1K0PFD7ATMA1](#) [2N7002W-G](#) [MCAC30N06Y-TP](#) [IPWS65R035CFD7AXKSA1](#)
[MCQ7328-TP](#) [SSM3J143TU,LXHF](#) [DMN12M3UCA6-7](#) [PJMF280N65E1_T0_00201](#) [PJMF380N65E1_T0_00201](#)
[PJMF280N60E1_T0_00201](#) [PJMF600N65E1_T0_00201](#)