

**Product features and main applications:**

NPNP five-layer structure of silicon bidirectional devices; with independent intellectual property rights of single-sided digging technology, table glass passivation process; multi-layer metallized electrodes on the back; with high blocking voltage and high temperature stability.

**Mainly used in:**

vacuum cleaners, power tools and other motor speed controllers; solid state relays; heating controllers (temperature regulation); other phase control circuits.

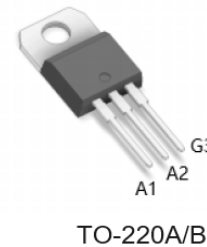
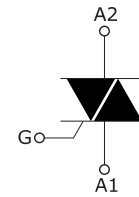

**Characteristics**

**Table 1. Absolute maximum ratings (Tj = 25°C unless otherwise stated)**

Symbol	Parameter name		value	Unit	
I <sub>T(RMS)</sub>	RMS on-state current (full sine wave)	BTA	T <sub>c</sub> =80 °C	16	A
		BTB	T <sub>c</sub> =90 °C		
I <sub>TSM</sub>	Non repetitive surge peak on-state current (full cycle, T <sub>j</sub> initial = 25 ° C)	F=50HZ t <sub>p</sub> =20ms		160	A
I <sup>2</sup> t	I <sup>2</sup> t value for fusing	t <sub>p</sub> =10ms		144	A <sup>2</sup> S
di/dt	Critical rate of rise of on-state current I <sub>G</sub> = 2 x I <sub>GT</sub> , t <sub>r</sub> ≤ 100 ns	T <sub>j</sub> =125		50	A/us

$V_{DRM}/V_{RRM}$	Off state repetitive peak voltage Reverse repetitive peak voltage	$T_j=25^\circ\text{C}$		600/800	V
$I_{GM}$	Peak gate current	$t_p=20\mu\text{s}$	$T_j=150^\circ\text{C}$	4	A
$P_{G(AV)}$	Average gate power dissipation		$T_j=150^\circ\text{C}$	1	W
$T_{stg}$ $T_j$	Storage junction temperature range Operating junction temperature range			-40 to+150 -40 to+150	$^\circ\text{C}$

**Table 2. Electrical characteristics ( $T_j = 25^\circ\text{C}$ , unless otherwise specified) -- 3 quadrants**

Symbol	Name and test conditions	Quadrant	Range	value			Unit
				Min	Typ	Max	
$I_{GT}$	$V_D=12\text{V}$ $R_L=100\Omega$	I II III	MAX	15	25	35	mA
$V_{GT}$				1.5			
$V_{GD}$	$V_D$ $V_{DRM}$ R 3.3 k $\Omega$ , $T_j$		MIN	0.2			V
$I_H$	$I_T = 100\text{ mA}$		MAX	60			mA
$I_L$	$I_G = 1.2 \times I_{GT}$		MAX	I - III		60	mA
				II		100	
dv/dt	$V_D = 67\% V_{DRM}$ , gate open, $T_j = 125^\circ\text{C}$		MIN	500			V/ $\mu\text{s}$
(dv/dt)c	Critical rise rate of commutation voltage $T_j = 150^\circ\text{C}$		MIN	10			V/ $\mu\text{s}$

**Table 3. Electrical characteristics (T<sub>j</sub> = 25 °C, unless otherwise specified) -Standard Triac (4 quadrants)**

Symbol	Name and test conditions	Quadrant	Range	value				Unit
I <sub>GT</sub>	V <sub>D</sub> =12V R <sub>L</sub> =100Ω	I - II -III	MAX	I	II	III	IV	mA
				≅ 25	≅ 35	≅ 35	≅ 120	
V <sub>GT</sub>	V <sub>D</sub> = V <sub>DRM</sub> , R <sub>L</sub> = 3.3 kΩ, T <sub>j</sub> = 125 ° C	IV	MAX	1.5				V
V <sub>GD</sub>			MIN	0.2				V
I <sub>H</sub>	I <sub>T</sub> =500mA		MAX	60				mA
I <sub>L</sub>	I <sub>G</sub> = 1.2 x I <sub>GT</sub>		MAX	60				mA
				100				
dv/dt	V <sub>D</sub> = 67% V <sub>DRM</sub> , gate open, T <sub>j</sub> = 125 ° C		MIN	500				V/us
(dv/dt) <sub>c</sub>	Critical rise rate of commutation voltage T <sub>J</sub> = 150 ° C		MIN	10				V/us

### Static parameters

Symbol	Parameter name			value	Unit
V <sub>TM</sub>	I <sub>TM</sub> = 32A	T <sub>j</sub> =25°C	MAX	1.50	V
V <sub>T0</sub>	threshold on-state voltage	T <sub>j</sub> =150°C	MAX	0.87	V
R <sub>d</sub>	Dynamic resistance	T <sub>j</sub> =150°C	MAX	14.6	mΩ
I <sub>DRM</sub> I <sub>RPM</sub>	V <sub>DRM</sub> = V <sub>RPM</sub>	T <sub>j</sub> =25°C	MAX	5	uA
		T <sub>j</sub> =150°C		1	mA
R <sub>th(j-c)</sub>	Junction to ambient	BTA	MAX	2.10	°C/W
		BTB		1.3	

**BTA16 characteristic curve**

**FIG.1** Maximum power dissipation versus RMS on-state current

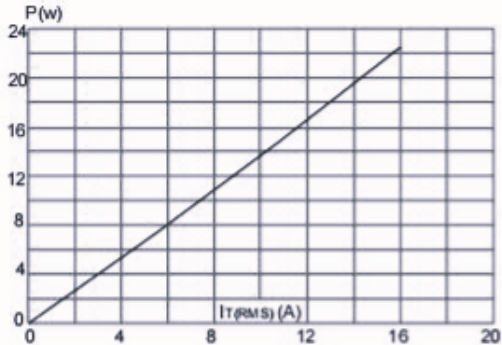

**FIG.3:** Surge peak on-state current versus number of cycles

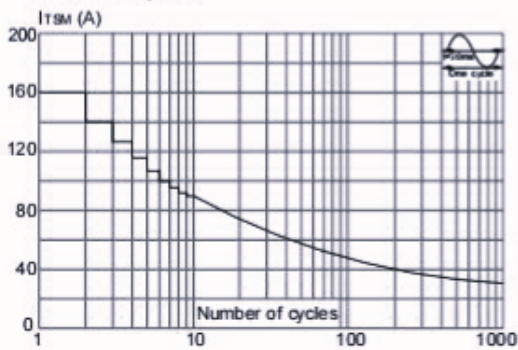

sinusoidal pulse with width  $t_p < 20\text{ms}$ , and  
 average value of  $I^2 t$  ( $dI/dt < 50\text{A}/\mu\text{s}$ )  
 $I^2 t$  ( $\text{A}^2\text{s}$ )

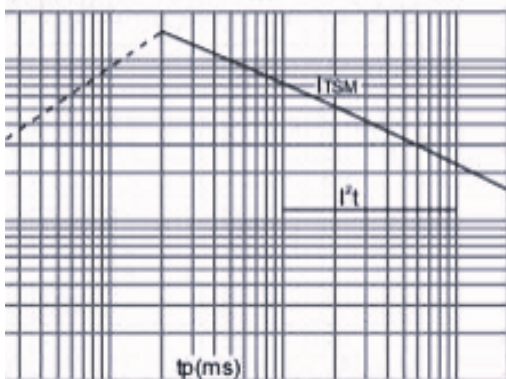

**FIG.2:** RMS on-state current versus case temperature

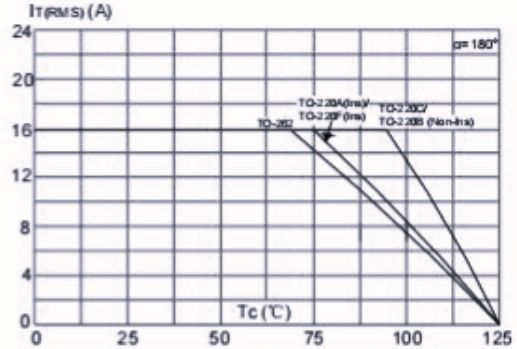

**FIG.4:** On-state characteristics (maximum values)

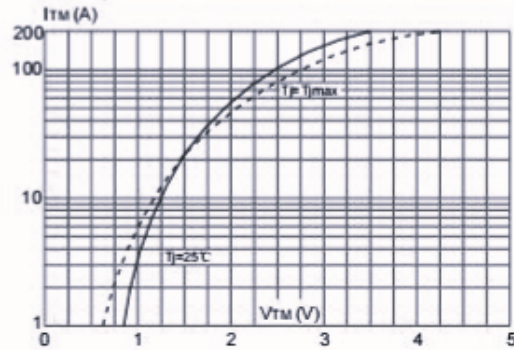

holding current and latching current versus  
 junction temperature

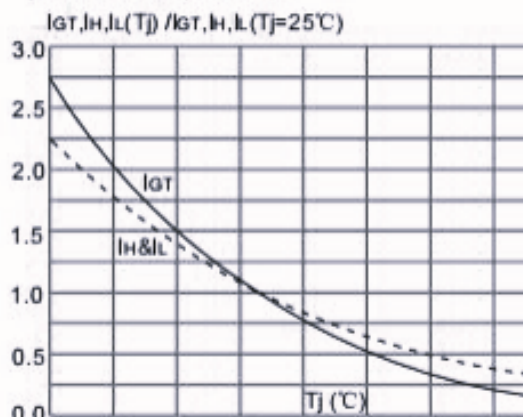

**TO-220A/TO-220B**

**Dimensional drawing: Unit:**

mm ( $\pm 0.1$ )

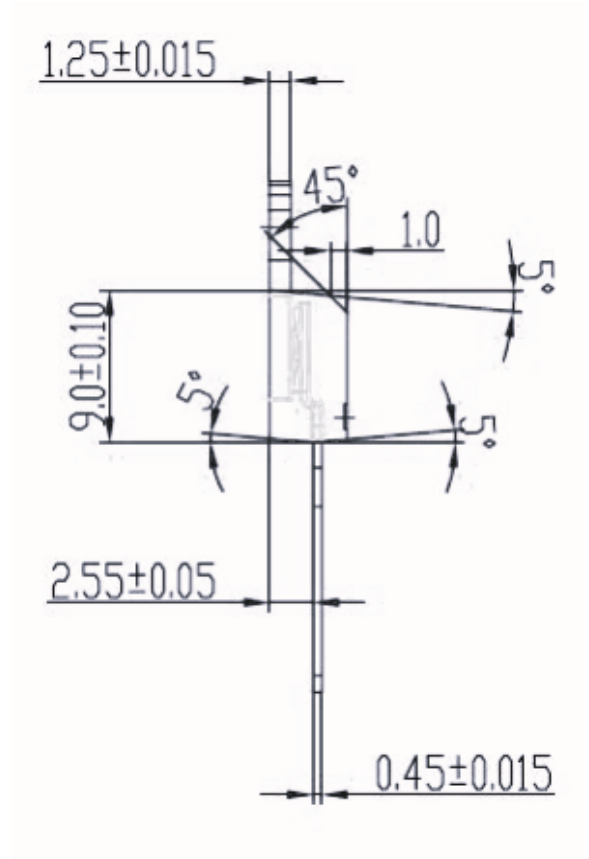
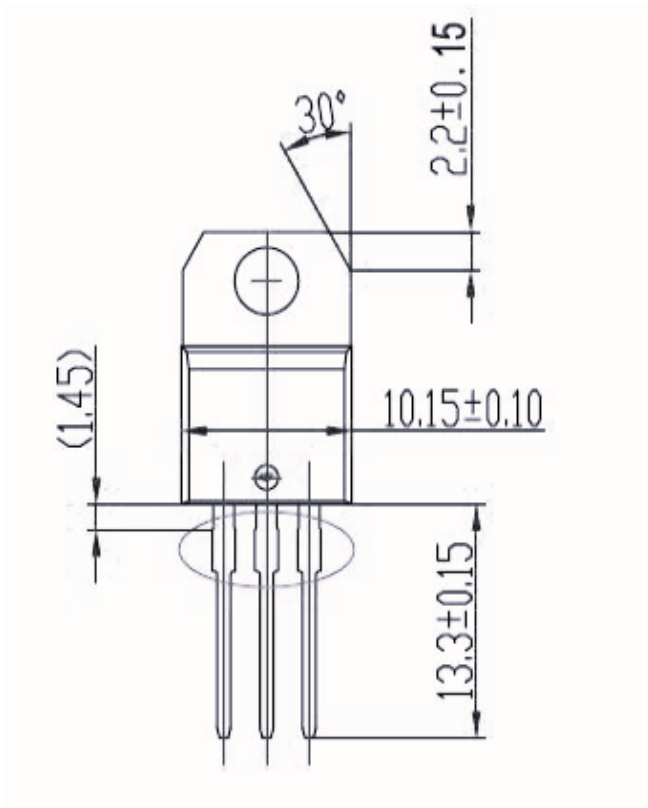

### Product Naming System

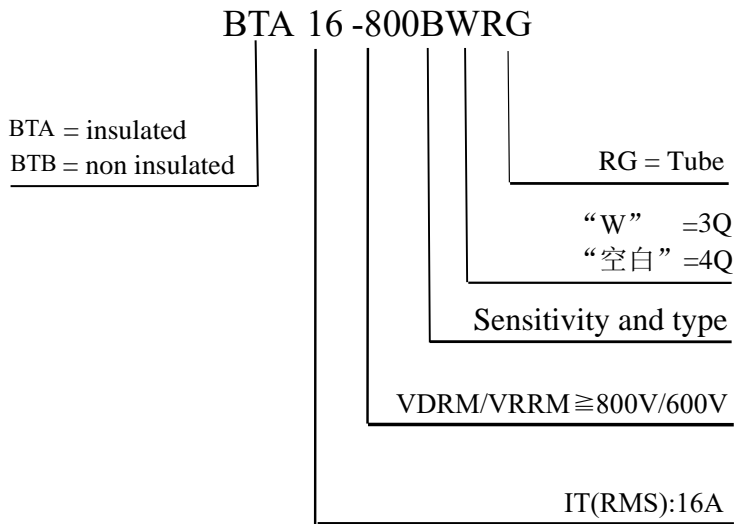

### Ordering information

Order code	Package	Baseqty	Deliverymode
UMW BTA16-600BRG	TO-220A	1000	Tube and box
UMW BTA16-600CRG	TO-220A	1000	Tube and box
UMW BTA16-800BRG	TO-220A	1000	Tube and box
UMW BTA16-600BWRG	TO-220A	1000	Tube and box
UMW BTA16-600CWRG	TO-220A	1000	Tube and box
UMW BTA16-800BWRG	TO-220A	1000	Tube and box
UMW BTA16-800CWRG	TO-220A	1000	Tube and box
UMW BTA16-600SWRG	TO-220A	1000	Tube and box
UMW BTA16-800SWRG	TO-220A	1000	Tube and box
UMW BTB16-600BRG	TO-220B	1000	Tube and box
UMW BTB16-600CRG	TO-220B	1000	Tube and box
UMW BTB16-800BRG	TO-220B	1000	Tube and box
UMW BTB16-600SWRG	TO-220B	1000	Tube and box
UMW BTB16-600CWRG	TO-220B	1000	Tube and box
UMW BTB16-600BWRG	TO-220B	1000	Tube and box
UMW BTB16-800CWRG	TO-220B	1000	Tube and box
UMW BTB16-800BWRG	TO-220B	1000	Tube and box