

Description

The FAN3111 2A gate driver is designed to drive an N-channel enhancement-mode MOSFET in low-side switching applications. FAN3111 has dual CMOS inputs with thresholds referenced to VDD for use with PWM controllers and other input-signal sources that operate from the same supply voltage as the driver.

Applications

- Switch-Mode Power Supplies
- Synchronous Rectifier Circuits
- Pulse Transformer Driver
- Logic to Power Buffer
- Motor Control

Features

- Dual inputs allow configuration as non-inverting or inverting with enable function
- CMOS logic inputs
- Input logic protection as low as -10V
- 4.5 to 25-V Single-Supply Range
- Internal resistance turns off driver when there is no input
- Operating Temperature Range of -40 to 125°C
- Turn on/Turn off Delays:
-- Ton/Toff = 20ns/20ns
- 2-A Peak Source and Sink-Drive Current

Pin Configuration

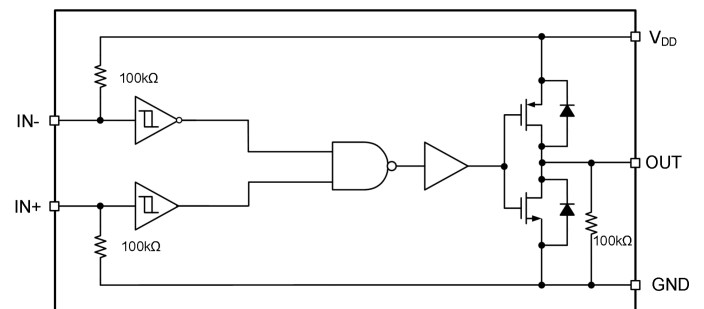

Pin Configuration and Functions

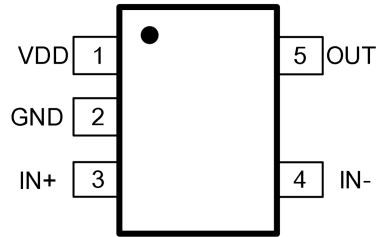

Figure 7-1 5-Pin SOT23-5 Package Top View

Table7-1 Pin Functions

PIN	NAME	DESCRIPTION
1	VDD	Bias supply input
2	GND	Ground: All signals are referenced to this pin.
3	IN+	Non-inverting Input
4	IN-	Inverting Input
5	OUT	Gate driven Ouput

Absolute Maximum Ratings

Stresses beyond those listed under Absolute Maximum Ratings may cause permanent damage to the device. All voltages are with respect to GND unless otherwise noted, Currents are positive into, negative out of the specified terminal, environment temperature is 25 °C.

Symbol	Definition	MIN	MAX	UNIT
V _{DD}	Supply voltage range	-0.3	25	V
V _O	OUT voltage range	-0.3	V _{DD} +0.3	
V _{IN}	IN+, IN- voltage	-12	25	

ESD Ratings

Symbol	Definition	MIN	MAX	UNIT
ESD	Human body model (HBM)	—	2000	V
	Charged device model (CDM)	—	500	V

Power Ratings

Symbol	Definition	MIN	MAX	UNIT
PD	SOIC package power (TA ≤70°C)	—	470	mW

Thermal Information

Symbol	Definition	MIN	MAX	UNIT
T _s	Storage temperature	-65	+150	°C
T _J	Operating junction temperature	—	+150	

Recommended Operating Conditions

To properly operate, device should be used in the following recommended conditions. All voltages are with respect to GND unless otherwise noted, Currents are positive into, negative out of the specified terminal, environment temperature is 25 °C.

Symbol	Definition	MIN	MAX	UNIT
V _{DD}	Supply voltage range	4.5	25	V
V _O	OUT voltage range	0	V _{DD}	
V _{IN}	IN+, IN- voltage	-10	25	
T _A	ambient temperature	-40	125	°C

Electrical Characteristics

TA= 25°C, VDD=15V(unless otherwise noted)

Symbol	Definition	MIN	TYP	MAX	UNIT
V _{IH}	Input signal high threshold	—	7.5	—	V
V _{IL}	Input signal low threshold	—	4.5	—	V
I _{IN+}	Input current(IN+=15V, IN-=0V)	—	150	300	μA
I _{IN-}	Input current(IN+=0V, IN-=15V)	—	—	1	μA
V _{OH}	High output voltage	V _{DD} -0.025	—	—	V
V _{OL}	Low output voltage	—	—	0.025	V
I _{o+}	Output high short-circuit pulse current	—	2	—	A
I _{o-}	Output low short-circuit pulse current	—	2	—	A
t _R	Rise time(CL=1nF)	—	—	15	ns
t _F	Fall time(CL=1nF)	—	—	15	ns
t _{ON}	Turn-on propagation delay(CL=1nF)	—	—	30	ns
t _{OFF}	Turn-off propagation delay(CL=1nF)	—	—	30	ns
I _{Q1}	VCC supply current(V _{IN-} =HIGH V _{IN+} =LOW)	—	—	30	μA
I _{Q2}	VCC supply current(V _{IN-} =LOW V _{IN+} =HIGH)	—	300	500	μA

Function description

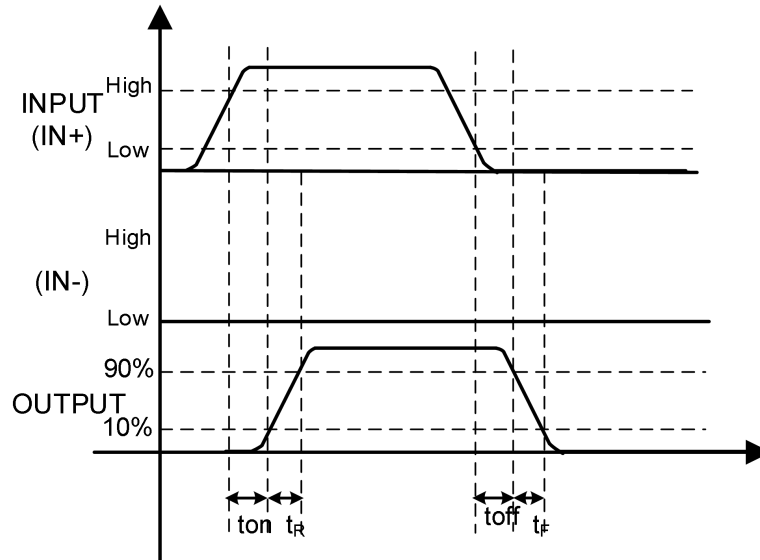

Figure 9-1 Input-Output waveform(non-inverting)

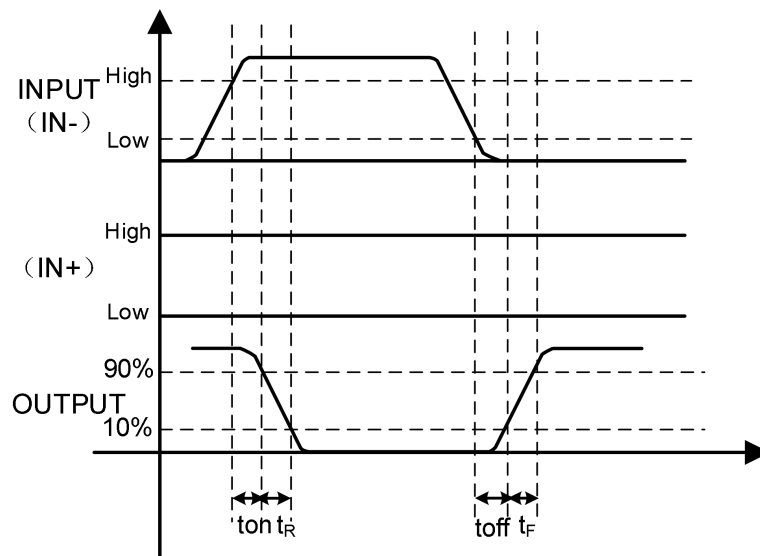

Figure 9-2 Input-Output waveform(inverting)

Function Block Diagram

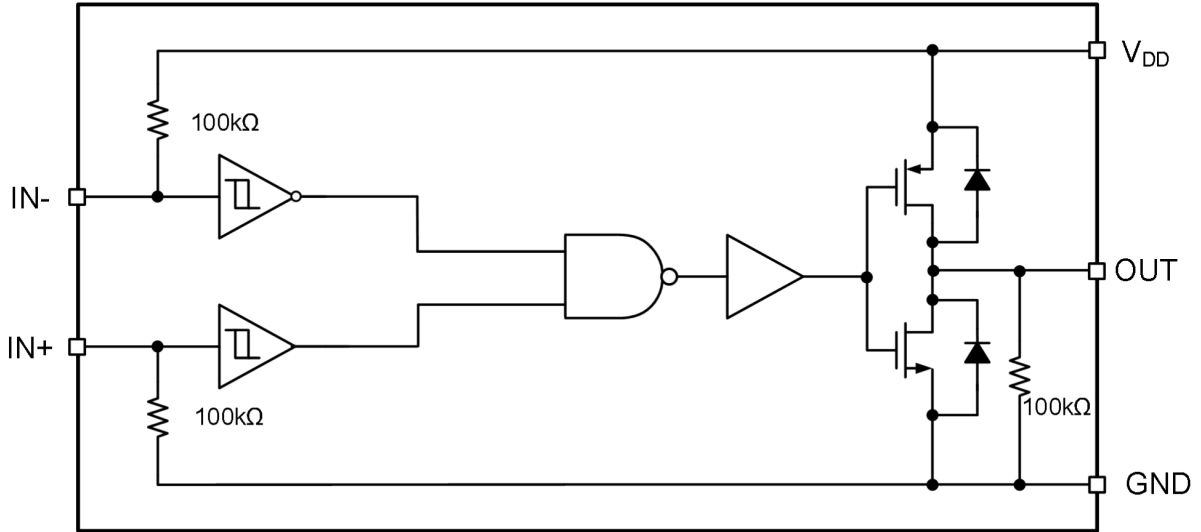

Figure 10-1 Function Block Diagram of FAN3111

Application message

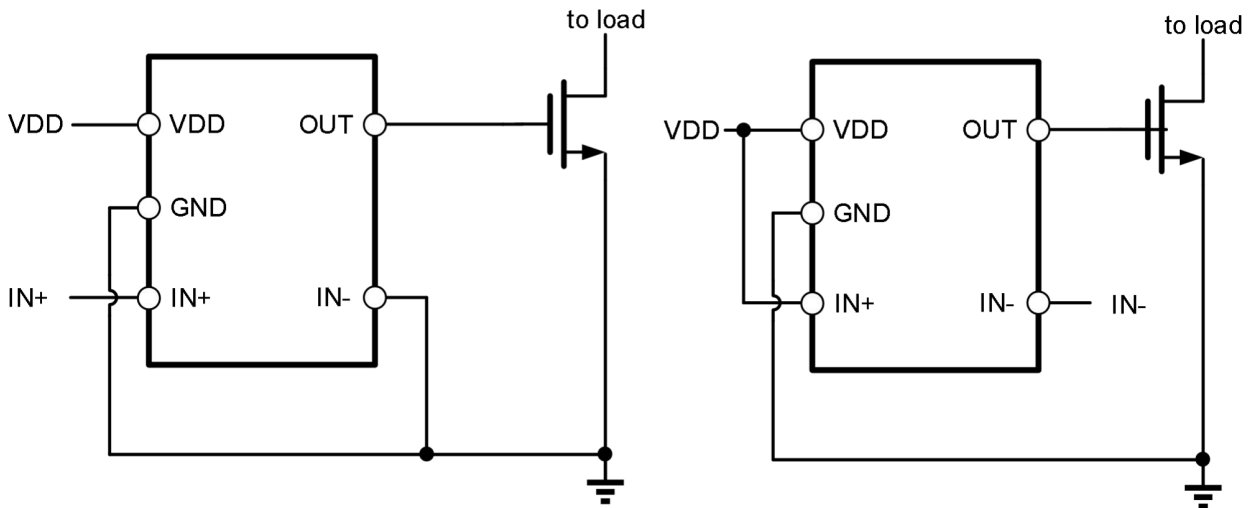

Figure10-2 Typical application circuit of FAN3111

Marking

Ordering information

Order code	Package	Baseqty	Deliverymode
UMW IRS2004STR	SOP-8	2500	Tape and reel

Marking

Ordering information

Order code	Package	Baseqty	Deliverymode
UMW FAN3111ESX	SOT23-5	3000	Tape and reel

X-ON Electronics

Largest Supplier of Electrical and Electronic Components

Click to view similar products for [Gate Drivers](#) category:

Click to view products by [Youtai](#) manufacturer:

Other Similar products are found below :

[56956](#) [57.404.7355.5](#) [LT4936](#) [57.904.0755.0](#) [5811-0902](#) [0131700000](#) [LTP70N06](#) [LVP640](#) [5J0-1000LG-SIL](#) [LY2-US-AC240](#) [LY3-UA-DC24](#) [LZNQ2-US-DC12](#) [LZP40N10](#) [60100564](#) [60249-1-CUT-TAPE](#) [0134220000](#) [6035](#) [60713816](#) [61161-90](#) [6131-204-23149P](#) [6131-205-17149P](#) [6131-209-15149P](#) [6131-218-17149P](#) [6131-220-21149P](#) [6131-260-2358P](#) [6131-265-11149P](#) [CS1HCPU63](#) [6150-5001](#) [CSB4](#) [CSK-38-60006](#) [CSK-38-60008](#) [621A](#) [622-4053LF](#) [6273](#) [M40N08MA-H](#) [M55155/29XH06](#) [64-807](#) [65-1930-6](#) [CV500ISB02](#) [M83723/88Y1407N](#) [CWD012-2](#) [CWD03-3](#) [CX3225SB16934D0PPSC2](#) [CX5032GB10000D0PPS02](#) [687-772NF1](#) [70.140.1653](#) [70.200.0653.0](#) [703001B01F060](#) [70-3601](#) [706006D02F0601](#)