

### Features

- $V_{DS}(V) = 60V$
- $I_D = 36A$  ( $V_{GS} = 10V$ )
- $R_{DS(ON)} < 22m\Omega$  ( $V_{GS} = 10V$ )  
 $R_{DS(ON)} < 27m\Omega$  ( $V_{GS} = 5V$ )
- Low Miller Charge
- Low  $Q_{rr}$  Body Diode

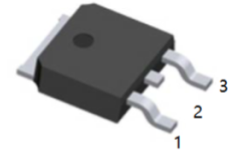

1.G 2.D 3.S  
TO-252(DPAK) top view

### Applications

- Motor / Body Load Control
- ABS Systems
- Powertrain Management
- Injection System
- DC-DC converters and Off-line UPS
- Distributed Power Architecture and VRMs
- Primary Switch for 12V and 24V systems

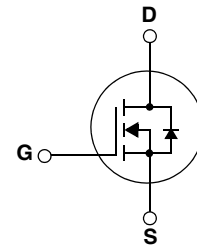

### Absolute Maximum Ratings $T_C = 25^\circ C$ unless otherwise noted

Symbol	Parameter	Ratings	Units
$V_{DSS}$	Drain to Source Voltage	60	V
$V_{GS}$	Gate to Source Voltage	$\pm 20$	V
$I_D$	Drain Current Continuous ( $V_{GS} = 10V$ )	37	A
	Drain Current Continuous ( $V_{GS} = 5V$ )	33	A
	Continuous ( $T_A = 25^\circ C$ , $V_{GS} = 10V$ , with $R_{\theta JA} = 52^\circ C/W$ )	7.4	A
	Pulsed	Figure 4	A
$E_{AS}$	Single Pulse Avalanche Energy (Note 1)	45	mJ
$P_D$	Power Dissipation	72	W
	Derate above $25^\circ C$	0.48	W/ $^\circ C$
$T_J, T_{STG}$	Operating and Storage Temperature	-55 to 175	$^\circ C$

### Thermal Characteristics

$R_{\theta JC}$	Maximum Thermal resistance Junction to Case TO-252	2.1	$^\circ C/W$
$R_{\theta JA}$	Thermal Resistance Junction to Ambient TO-252, 1in <sup>2</sup> copper pad area	52	$^\circ C/W$

### Electrical Characteristics $T_J = 25^\circ\text{C}$ unless otherwise noted

Symbol	Parameter	Test Conditions	Min	Typ	Max	Units
--------	-----------	-----------------	-----	-----	-----	-------

#### Off Characteristics

$B_{VDSS}$	Drain to Source Breakdown Voltage	$I_D = 250\mu\text{A}, V_{GS} = 0\text{V}$	60	-	-	V
$I_{DSS}$	Zero Gate Voltage Drain Current	$V_{DS} = 48\text{V}$ $V_{GS} = 0\text{V}$	-	-	1	$\mu\text{A}$
		$T_C = 150^\circ\text{C}$	-	-	250	
$I_{GSS}$	Gate to Source Leakage Current	$V_{GS} = \pm 20\text{V}$	-	-	$\pm 100$	nA

#### On Characteristics

$V_{GS(TH)}$	Gate to Source Threshold Voltage	$V_{GS} = V_{DS}, I_D = 250\mu\text{A}$	1	1.6	2	V
$R_{DS(ON)}$	Drain to Source On Resistance	$I_D = 32\text{A}, V_{GS} = 10\text{V}$	-	18	22	$\text{m}\Omega$
		$I_D = 29\text{A}, V_{GS} = 5\text{V}$	-	22	27	

#### Dynamic Characteristics

$C_{iss}$	Input Capacitance	$V_{DS} = 25\text{V}, V_{GS} = 0\text{V},$ $f = 1\text{MHz}$	-	1420	1890	pF	
$C_{oss}$	Output Capacitance		-	150	200	pF	
$C_{rss}$	Reverse Transfer Capacitance		-	65	100	pF	
$R_G$	Gate Resistance	$f = 1\text{MHz}$	-	3.5	-	$\Omega$	
$Q_g$	Total Gate Charge at 10V	$V_{GS} = 0\text{V to } 10\text{V}$	$V_{DD} = 30\text{V}$ $I_D = 35\text{A}$	-	24	34	nC
$Q_g$	Total Gate Charge at 5V	$V_{GS} = 0\text{V to } 5\text{V}$		-	13	18	nC
$Q_{g(th)}$	Threshold Gate Charge	$V_{GS} = 0\text{V to } 1\text{V}$		-	1.3	-	nC
$Q_{gs}$	Gate to Source Gate Charge			-	4.0	-	nC
$Q_{gs2}$	Gate Charge Threshold to Plateau			-	2.7	-	nC
$Q_{gd}$	Gate to Drain "Miller" Charge			-	5.0	-	nC

$t_{on}$	Turn-On Time	$V_{DD} = 30V, I_D = 35A$ $V_{GS} = 5V, R_{GS} = 11\Omega$	-	-	130	ns
$t_{d(on)}$	Turn-On Delay Time		-	12	-	ns
$t_r$	Rise Time		-	75	-	ns
$t_{d(off)}$	Turn-Off Delay Time		-	26	-	ns
$t_f$	Fall Time		-	34	-	ns
$t_{off}$	Turn-Off Time		-	-	90	ns

### Drain-Source Diode Characteristics

$V_{SD}$	Source to Drain Diode Voltage	$I_{SD} = 32A$	-	-	1.25	V
		$I_{SD} = 16A$	-	-	1.0	V
$t_{rr}$	Reverse Recovery Time	$I_F = 35A, di/dt = 100A/\mu s$	-	-	39	ns
$Q_{rr}$	Reverse Recovery Charge	$I_F = 35A, di/dt = 100A/\mu s$	-	-	35	nC

**Notes:**

1: Starting  $T_J = 25^\circ C$ ,  $L = 110\mu H$ ,  $I_{AS} = 28A$ ,  $V_{DD} = 54V$ ,  $V_{GS} = 10V$ .

Typical Characteristics  $T_J = 25^\circ\text{C}$  unless otherwise noted

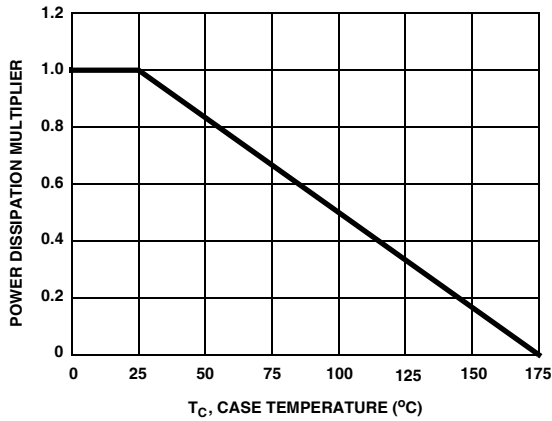

Figure 1. Normalized Power Dissipation vs Case Temperature

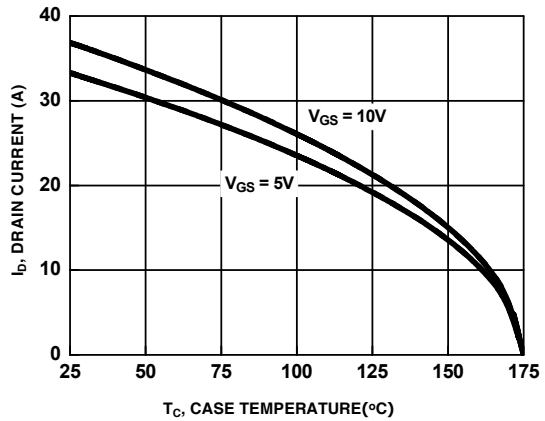

Figure 2. Maximum Continuous Drain Current vs Case Temperature

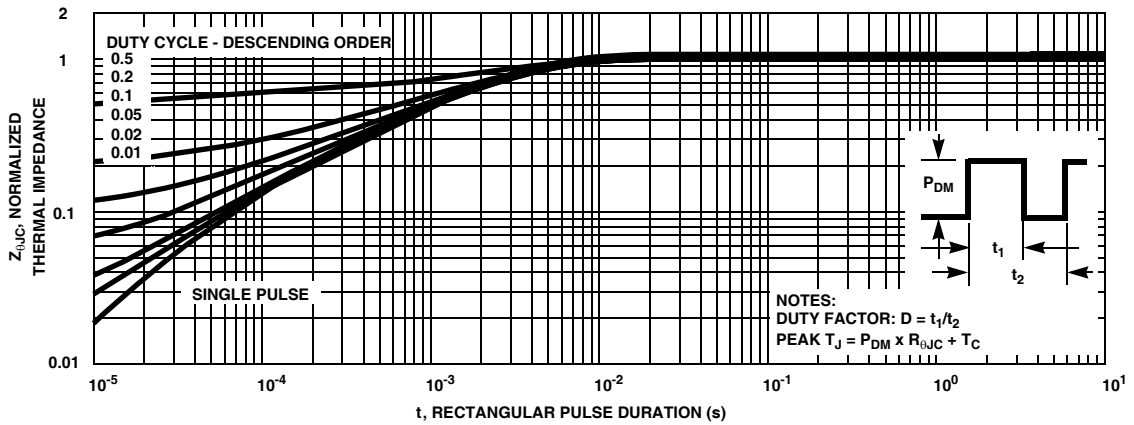

Figure 3. Normalized Maximum Transient Thermal Impedance

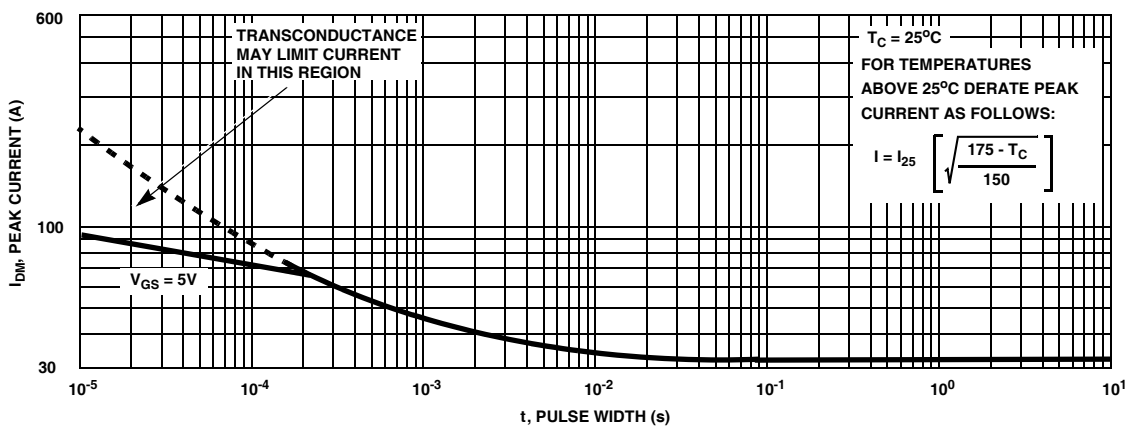

Figure 4. Peak Current Capability

Typical Characteristics  $T_J = 25^\circ\text{C}$  unless otherwise noted

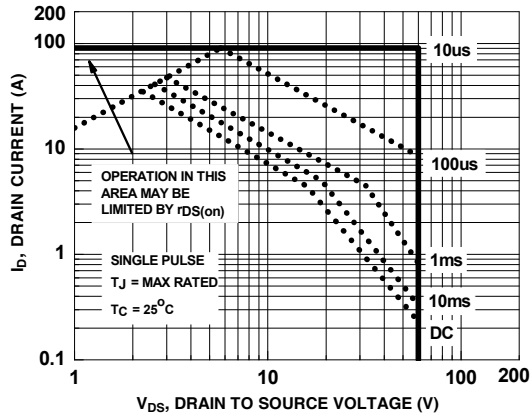

Figure 5. Forward Bias Safe Operating Area

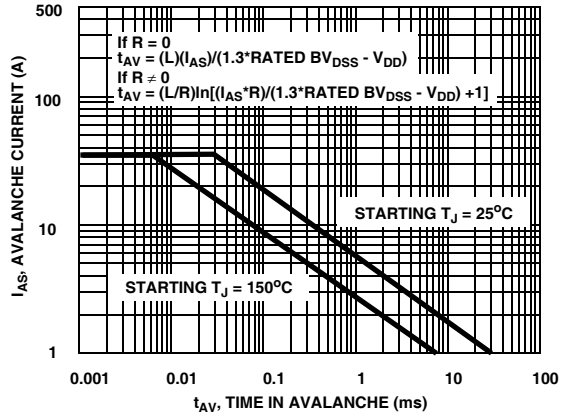

Figure 6. Unclamped Inductive Switching Capability

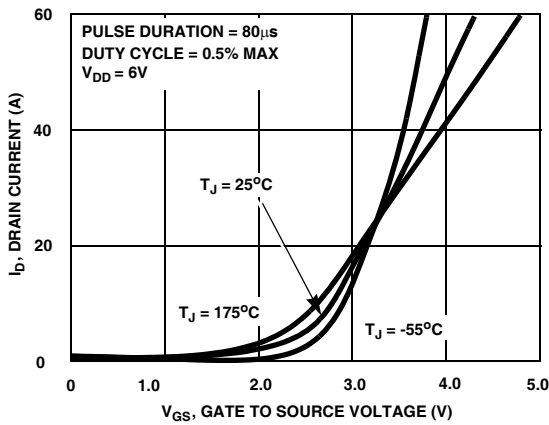

Figure 7. Transfer Characteristics

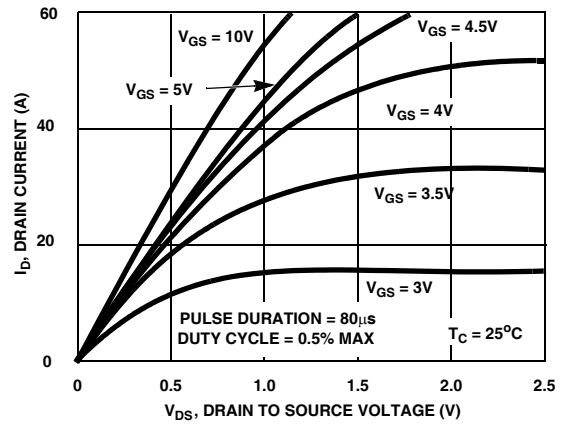

Figure 8. Saturation Characteristics

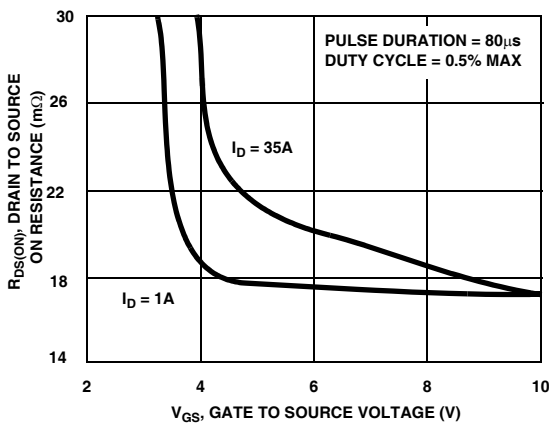

Figure 9. Drain to Source On Resistance vs Gate Voltage and Drain Current

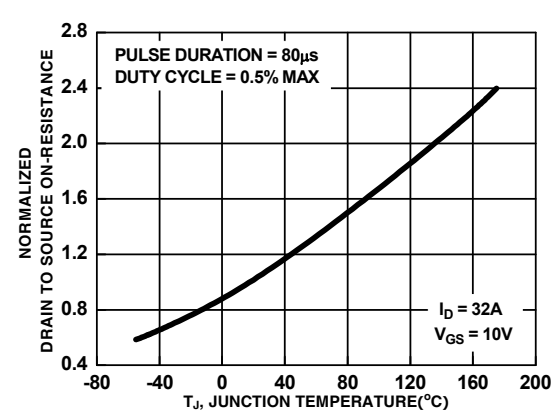

Figure 10. Normalized Drain to Source On Resistance vs Junction Temperature

Typical Characteristics  $T_J = 25^\circ\text{C}$  unless otherwise noted

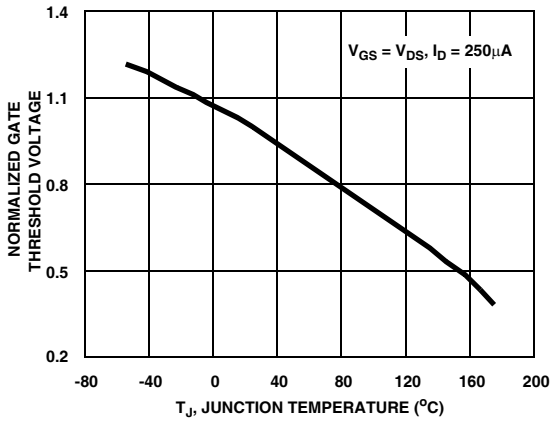

Figure 11. Normalized Gate Threshold Voltage vs Junction Temperature

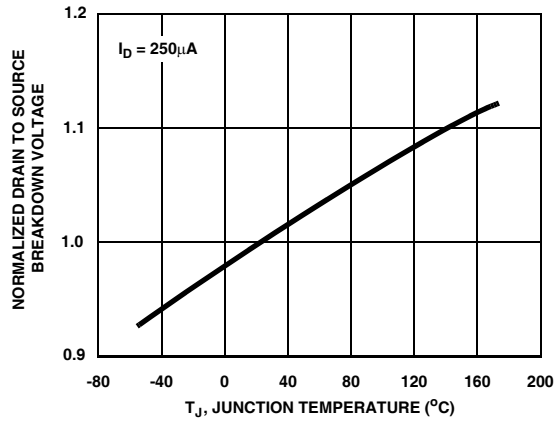

Figure 12. Normalized Drain to Source Breakdown Voltage vs Junction Temperature

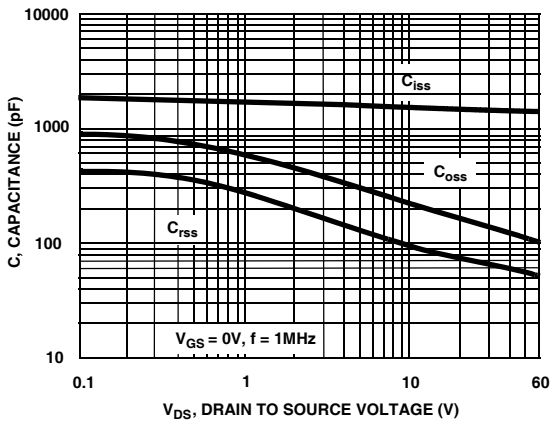

Figure 13. Capacitance vs Drain to Source Voltage

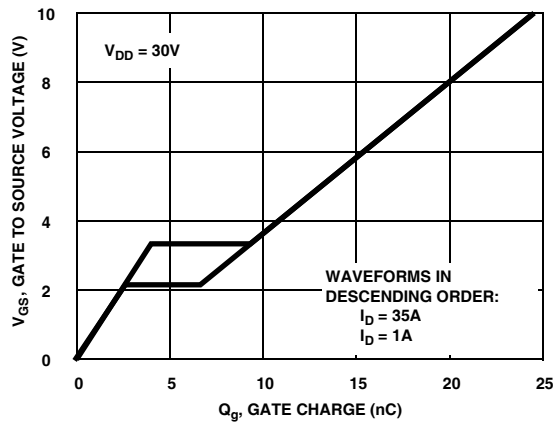
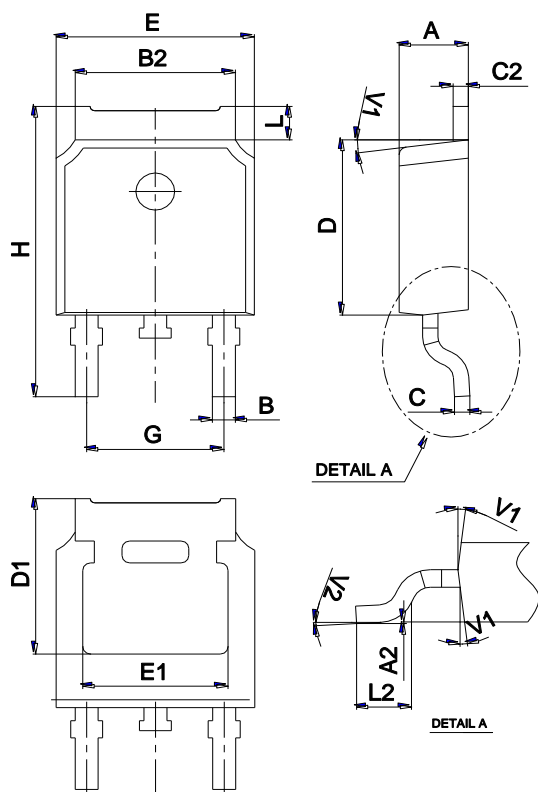

Figure 14. Gate Charge Waveforms for Constant Gate Current

Package Mechanical Data TO-252



Ref.	Dimensions					
	Millimeters			Inches		
	Min.	Typ.	Max.	Min.	Typ.	Max.
A	2.10		2.50	0.083		0.098
A2	0		0.10	0		0.004
B	0.66		0.86	0.026		0.034
B2	5.18		5.48	0.202		0.216
C	0.40		0.60	0.016		0.024
C2	0.44		0.58	0.017		0.023
D	5.90		6.30	0.232		0.248
D1	5.30REF			0.209REF		
E	6.40		6.80	0.252		0.268
E1	4.63			0.182		
G	4.47		4.67	0.176		0.184
H	9.50		10.70	0.374		0.421
L	1.09		1.21	0.043		0.048
L2	1.35		1.65	0.053		0.065
V1		7°			7°	
V2	0°		6°	0°		6°

Marking

Ordering information

Order code	Package	Baseqty	Deliverymode
UMW FDD5810	TO-252	2500	Tape and reel

## X-ON Electronics

Largest Supplier of Electrical and Electronic Components

*Click to view similar products for [MOSFET](#) category:*

*Click to view products by [Youtai](#) manufacturer:*

Other Similar products are found below :

[IRFD120](#) [JANTX2N5237](#) [BUK455-60A/B](#) [MIC4420CM-TR](#) [VN1206L](#) [NDP4060](#) [SI4482DY](#) [IPS70R2K0CEAKMA1](#) [SQD23N06-31L-GE3](#)  
[TK16J60W,S1VQ\(O](#) [2SK2614\(TE16L1,Q\)](#) [DMN1017UCP3-7](#) [DMN1053UCP4-7](#) [SQJ469EP-T1-GE3](#) [NTE2384](#) [DMC2700UDMQ-7](#)  
[DMN2080UCB4-7](#) [DMN61D9UWQ-13](#) [US6M2GTR](#) [DMN31D5UDJ-7](#) [DMP22D4UFO-7B](#) [DMN1006UCA6-7](#) [DMN16M9UCA6-7](#)  
[STF5N65M6](#) [IRF40H233XTMA1](#) [STU5N65M6](#) [DMN6022SSD-13](#) [DMN13M9UCA6-7](#) [DMTH10H4M6SPS-13](#) [DMN2990UFB-7B](#)  
[IPB80P04P405ATMA2](#) [2N7002W-G](#) [MCAC30N06Y-TP](#) [MCQ7328-TP](#) [BXP7N65D](#) [BXP4N65F](#) [AOL1454G](#) [WMJ80N60C4](#) [BXP2N20L](#)  
[BXP2N65D](#) [BXT1150N10J](#) [BXT1700P06M](#) [TSM60NB380CP](#) [ROG](#) [RQ7L055BGTCR](#) [DMNH15H110SK3-13](#) [SLF10N65ABV2](#)  
[BSO203SP](#) [BSO211P](#) [IPA60R230P6](#) [IPA60R460CE](#)