

Features

- Excellent gate charge x R(on) product (FOM)
- Very low on-resistance RDS (on)
- Ideal for high-frequency switching and synchronous rectification
- V_{DS}(V) =100V
- I_D =120A (V_{GS} = 10V)
- R_{DS(ON)} <2.7mΩ (V_{GS} =10V)

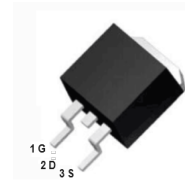

TO- 263

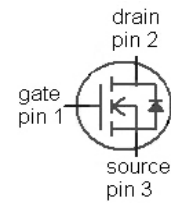

MOSFET Maximum Ratings T_j = 25°C unless otherwise specified

Parameter	Symbol	Conditions	Value	Unit
Continuous drain current	I _D	T _C =25 °C ²⁾	120	A
		T _C =100 °C	120	
Pulsed drain current ²⁾	I _{D,pulse}	T _C =25 °C	480	
Avalanche energy, single pulse	E _{AS}	I _D =100 A, R _{GS} =25 Ω	1000	mJ
Gate source voltage	V _{GS}		±20	V
Power dissipation	P _{tot}	T _C =25 °C	300	W
Operating and storage temperature	T _j , T _{stg}		-55 ... 175	°C
IEC climatic category; DIN IEC 68-1			55/175/56	

Electrical characteristics , at $T_j = 25^\circ\text{C}$, unless otherwise specified

Parameter	Symbol	Conditions	Values			Unit
			min.	typ.	max.	
Thermal resistance, junction - case	R_{thJC}				0.5	K/W
Thermal resistance, junction - ambient	R_{thJA}	minimal footprint			62	
		6 cm ² cooling area ³⁾			40	
Drain-source breakdown voltage	$V_{(BR)DSS}$	$V_{GS}=0\text{ V}, I_D=1\text{ mA}$	100			V
Gate threshold voltage	$V_{GS(th)}$	$V_{DS}=V_{GS}, I_D=275\text{ }\mu\text{A}$	2	2.7	3.5	
Zero gate voltage drain current	I_{DSS}	$V_{DS}=100\text{ V}, V_{GS}=0\text{ V}, T_j=25^\circ\text{C}$		0.1	1	μA
		$V_{DS}=100\text{ V}, V_{GS}=0\text{ V}, T_j=125^\circ\text{C}$		10	100	
Gate-source leakage current	I_{GSS}	$V_{GS}=20\text{ V}, V_{DS}=0\text{ V}$		1	100	nA
Drain-source on-state resistance	$R_{DS(on)}$	$V_{GS}=10\text{ V}, I_D=100\text{ A}$		2.3	2.7	m Ω
		$V_{GS}=6\text{ V}, I_D=50\text{ A}$		2.8	4.5	
Gate resistance	R_G			1.9	-	Ω
Transconductance	g_{fs}	$ V_{DS} >2 I_D R_{DS(on)max}, I_D=100\text{ A}$	94	188	-	S

Device on 40 mm x 40 mm x 1.5 mm epoxy PCB FR4 with 6 cm² (one layer , 70 um thick) copper area for drainconnection . PCB is vertical in still air.

Dynamic characteristics

Parameter	Symbol	Conditions	Values			Unit
			min.	typ.	max.	
Input capacitance	C_{iss}	$V_{GS}=0\text{ V}, V_{DS}=50\text{ V}, f=1\text{ MHz}$		11100	14800	pF
Output capacitance	C_{oss}			1940	2580	
Reverse transfer capacitance	C_{rss}			69		
Turn-on delay time	$t_{d(on)}$	$V_{DD}=50\text{ V}, V_{GS}=10\text{ V}, I_D=100\text{ A}, R_G=1.6\ \Omega$		34		ns
Rise time	t_r			58		
Turn-off delay time	$t_{d(off)}$			84		
Fall time	t_f			28		
Gate to source charge	Q_{gs}	$V_{DD}=50\text{ V}, I_D=100\text{ A}, V_{GS}=0\text{ to }10\text{ V}$		48		nC
Gate to drain charge	Q_{gd}			27		
Switching charge	Q_{sw}			42		
Gate charge total	Q_g			155	206	
Gate plateau voltage	$V_{plateau}$			4.3		
Output charge	Q_{oss}	$V_{DD}=50\text{ V}, V_{GS}=0\text{ V}$		205	273	nC
Diode continuous forward current	I_S	$T_C=25\text{ }^\circ\text{C}$			120	A
Diode pulse current	$I_{S,pulse}$				480	
Diode forward voltage	V_{SD}	$V_{GS}=0\text{ V}, I_F=100\text{ A}, T_j=25\text{ }^\circ\text{C}$		1	1.2	V
Reverse recovery time	t_{rr}	$V_R=50\text{ V}, I_F=100\text{ A}, di_F/dt=100\text{ A}/\mu\text{s}$		86		ns
Reverse recovery charge	Q_{rr}			232		

1 Power dissipation

$P_{tot}=f(T_C)$

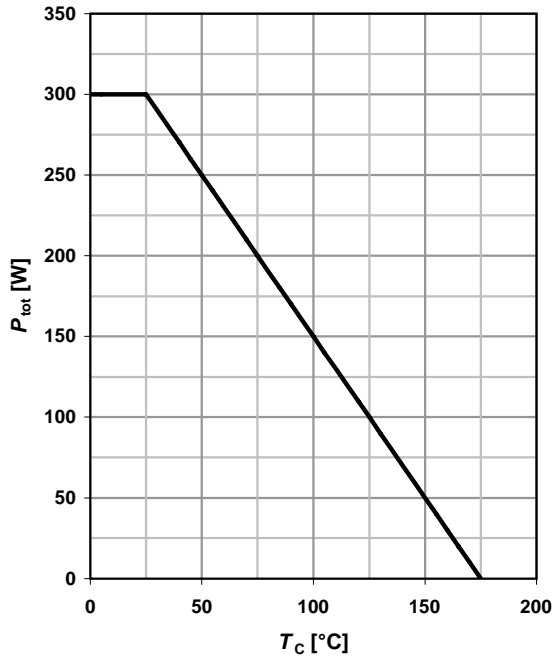

2 Drain current

$I_D=f(T_C); V_{GS} \geq 10\text{ V}$

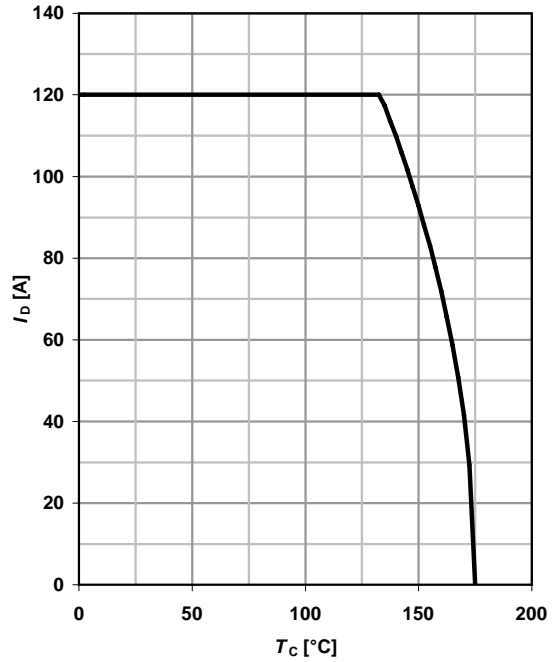

3 Safe operating area

$I_D=f(V_{DS}); T_C=25\text{ °C}; D=0$

parameter: t_p

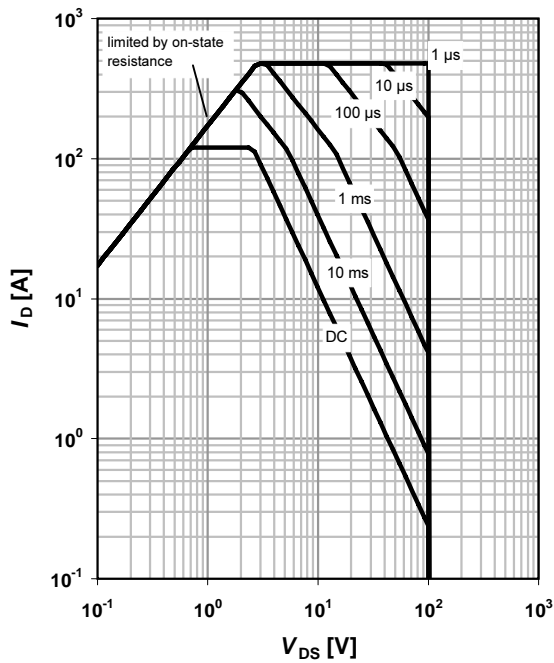

4 Max. transient thermal impedance

$Z_{thJC}=f(t_p)$

parameter: $D=t_p/T$

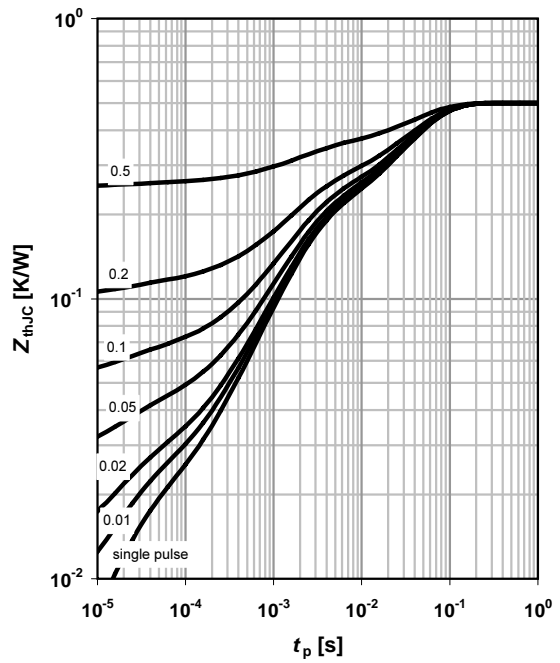

5 Typ. output characteristics

$I_D = f(V_{DS}); T_j = 25\text{ }^\circ\text{C}$

parameter: V_{GS}

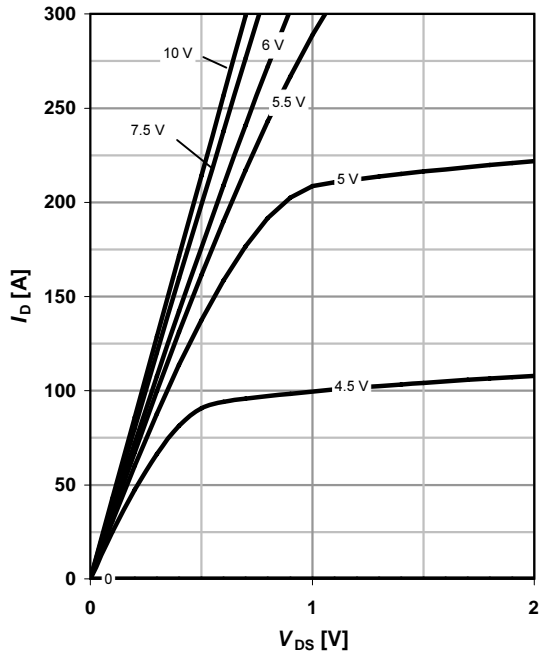

6 Typ. drain-source on resistance

$R_{DS(on)} = f(I_D); T_j = 25\text{ }^\circ\text{C}$

parameter: V_{GS}

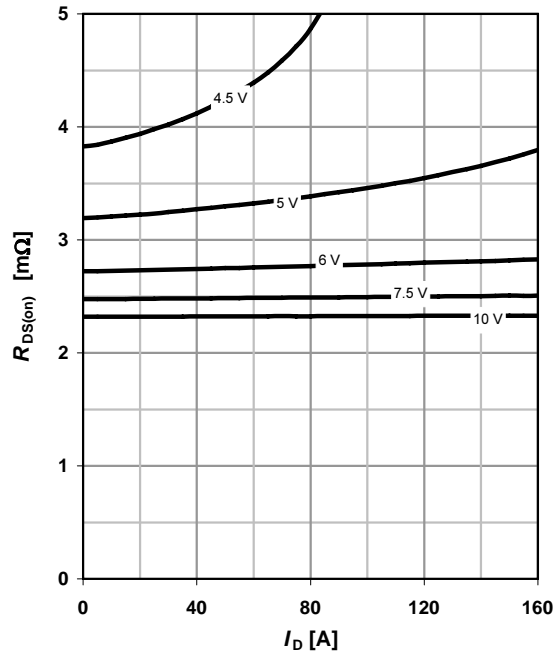

7 Typ. transfer characteristics

$I_D = f(V_{GS}); |V_{DS}| > 2|I_D|R_{DS(on)max}$

parameter: T_j

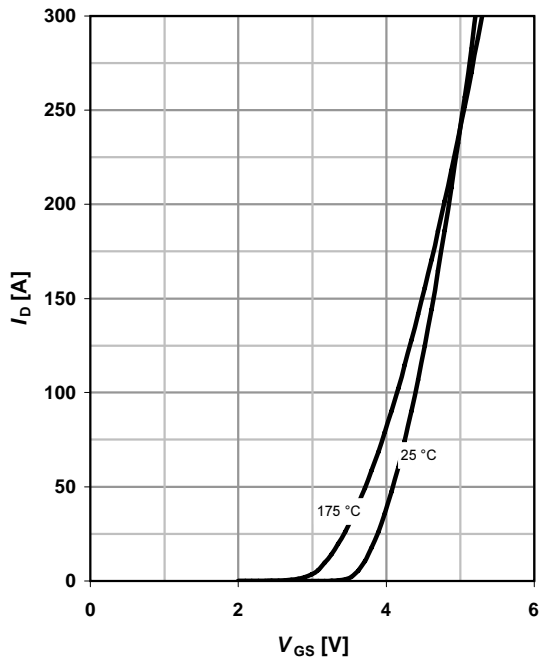

8 Typ. forward transconductance

$g_{fs} = f(I_D); T_j = 25\text{ }^\circ\text{C}$

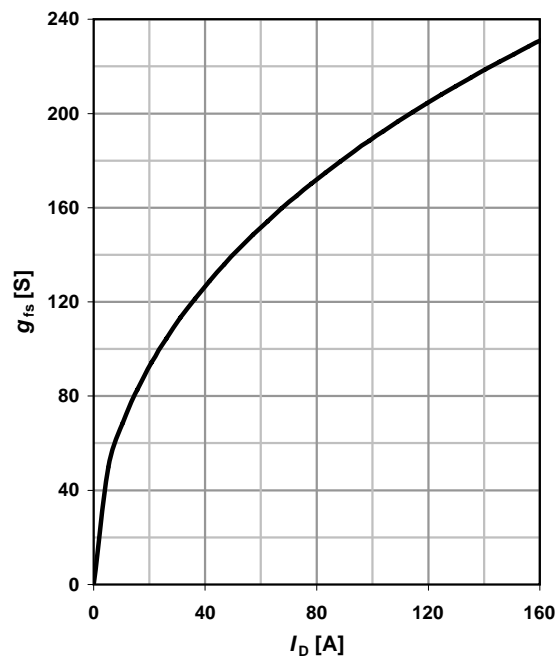

9 Drain-source on-state resistance

$R_{DS(on)} = f(T_j); I_D = 100 \text{ A}; V_{GS} = 10 \text{ V}$

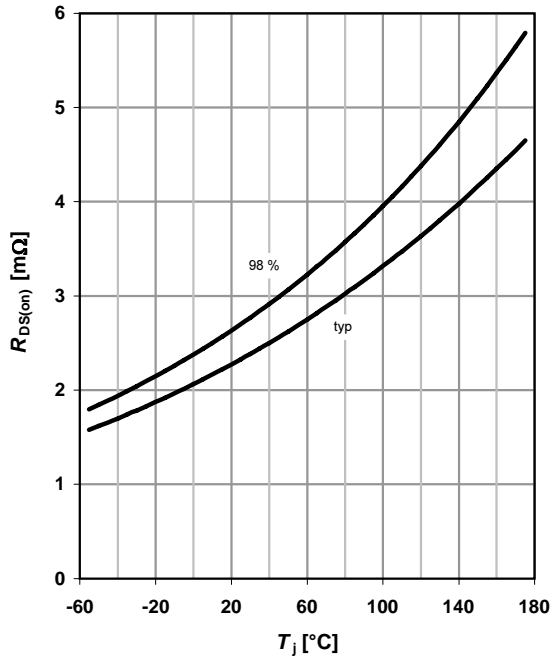

10 Typ. gate threshold voltage

$V_{GS(th)} = f(T_j); V_{GS} = V_{DS}$

parameter: I_D

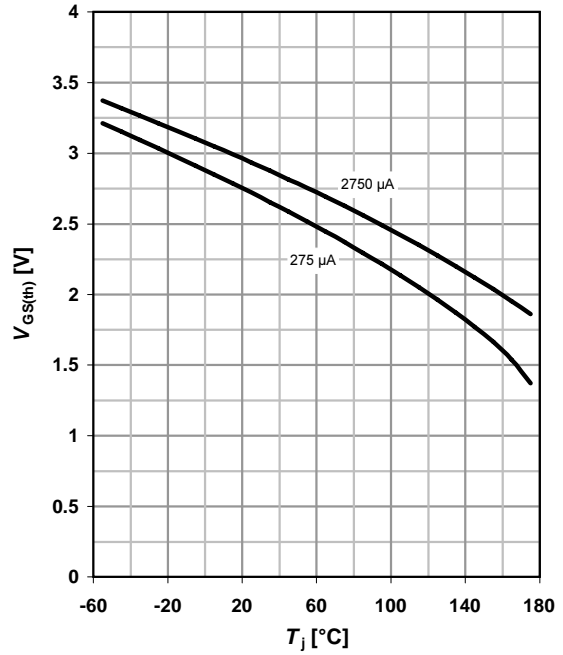

11 Typ. capacitances

$C = f(V_{DS}); V_{GS} = 0 \text{ V}; f = 1 \text{ MHz}$

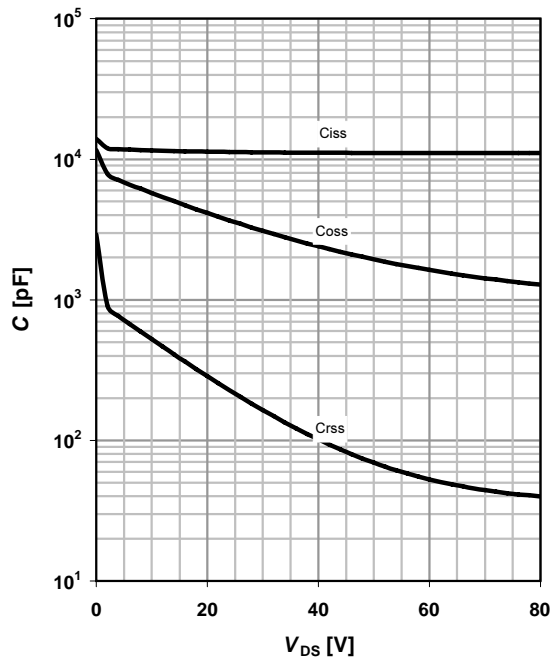

12 Forward characteristics of reverse diode

$I_F = f(V_{SD})$

parameter: T_j

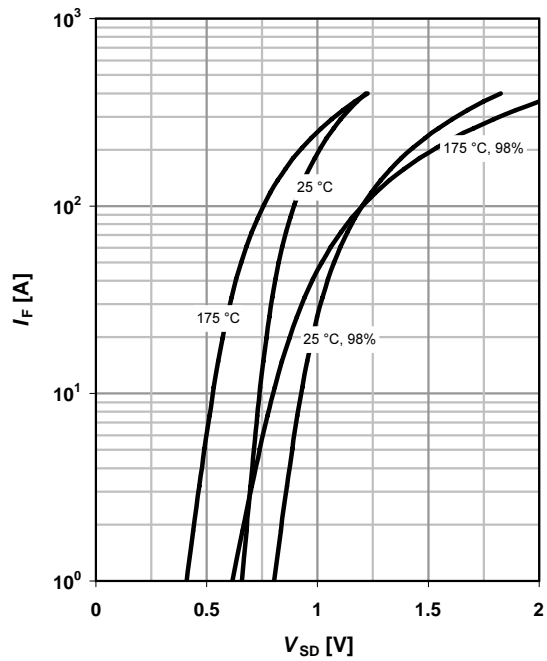

13 Avalanche characteristics

$I_{AS}=f(t_{AV}); R_{GS}=25 \Omega$

parameter: $T_{j(start)}$

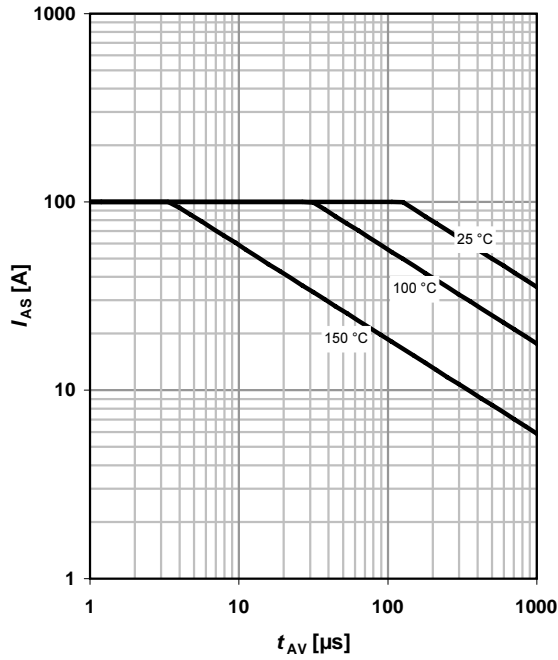

14 Typ. gate charge

$V_{GS}=f(Q_{gate}); I_D=100 \text{ A pulsed}$

parameter: V_{DD}

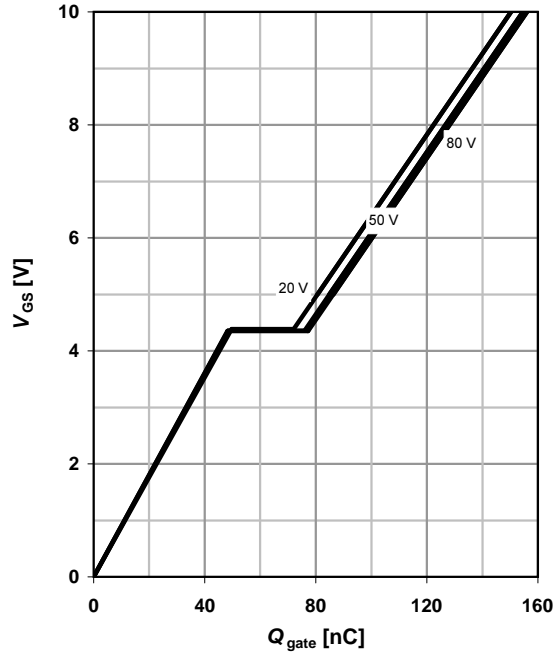

15 Drain-source breakdown voltage

$V_{BR(DSS)}=f(T_j); I_D=1 \text{ mA}$

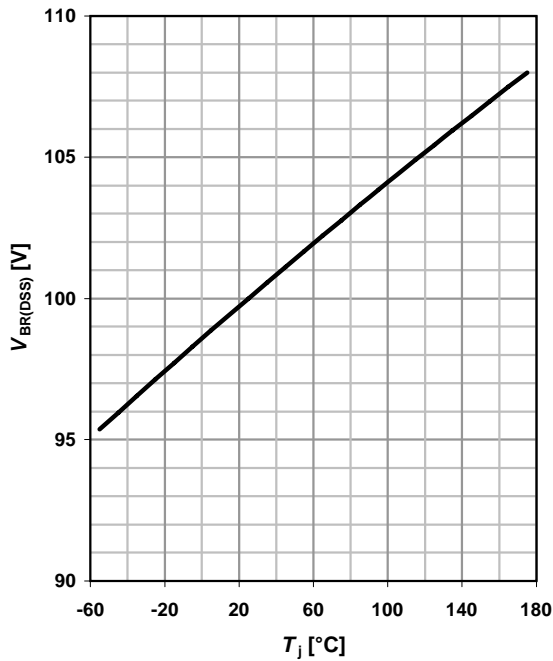

16 Gate charge waveforms

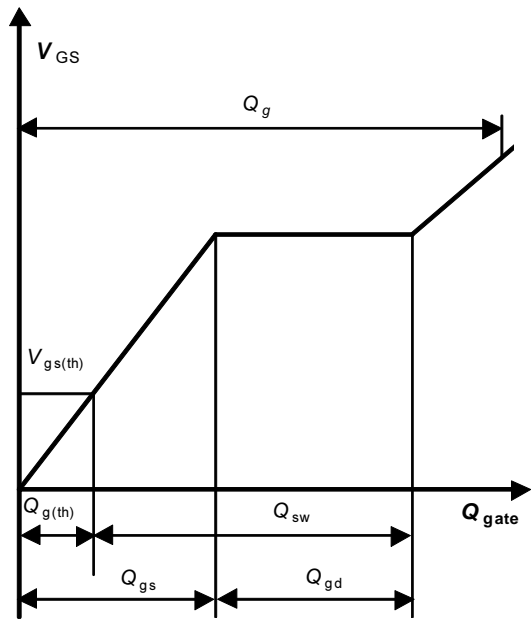

TO-263 Package Outline Drawing

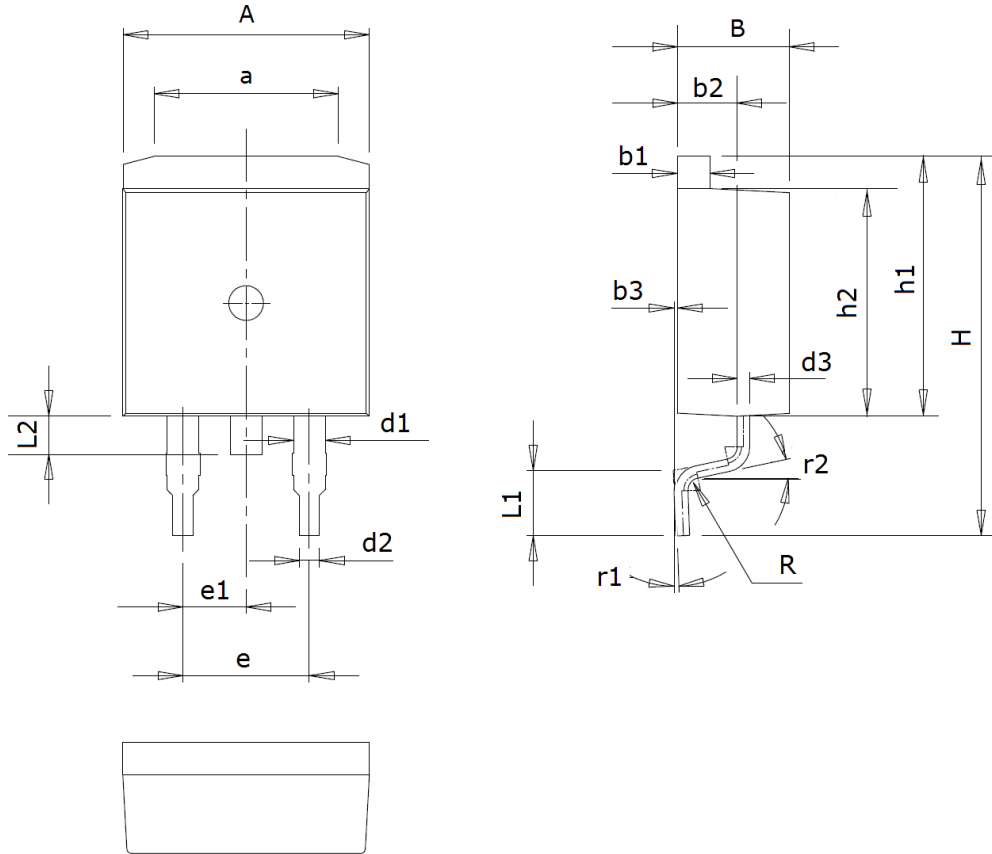

Symbol	Dimensions (mm)	Symbol	Dimensions (mm)	Symbol	Dimensions (mm)
A	9.7~10.3	d2	0.7~0.9	L1	2.4~2.9
a	7.0~7.8	d3	0.4~0.6	L2	1.3~1.8
B	4.3~4.7	e	5.08 (typ)	R	0.5(typ)
b1	1.25~1.35	e1	2.54 (typ)	r1	0~8°
b2	2.2~2.6	H	14.8~15.6	r2	12° (typ)
b3	0~0.2	h1	10.2~10.7		
d1	1.2~1.4	h2	8.9~9.4		

Marking

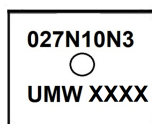

Ordering information

Order code	Package	Baseqty	Deliverymode
UMW IPB027N10N3G	TO-263	800	Tape and reel

X-ON Electronics

Largest Supplier of Electrical and Electronic Components

Click to view similar products for [MOSFET](#) category:

Click to view products by [Youtai](#) manufacturer:

Other Similar products are found below :

[IRFD120](#) [JANTX2N5237](#) [2SK2267\(Q\)](#) [BUK455-60A/B](#) [TK100A10N1,S4X\(S](#) [MIC4420CM-TR](#) [VN1206L](#) [NDP4060](#) [SI4482DY](#)
[IRS2092STRPBF-EL](#) [IPS70R2K0CEAKMA1](#) [TK31J60W5,S1VQ\(O](#) [TK31J60W,S1VQ\(O](#) [TK16J60W,S1VQ\(O](#) [2SK2614\(TE16L1,Q\)](#)
[DMN1017UCP3-7](#) [EFC2J004NUZTDG](#) [P85W28HP2F-7071](#) [DMN1053UCP4-7](#) [NTE2384](#) [DMC2700UDMQ-7](#) [DMN2080UCB4-7](#)
[DMN61D9UWQ-13](#) [US6M2GTR](#) [DMN31D5UDJ-7](#) [DMP22D4UFO-7B](#) [IPS60R3K4CEAKMA1](#) [DMN1006UCA6-7](#) [DMN16M9UCA6-7](#)
[STF5N65M6](#) [IRF40H233XTMA1](#) [STU5N65M6](#) [DMN6022SSD-13](#) [DMN13M9UCA6-7](#) [DMTH10H4M6SPS-13](#) [IPS60R360PFD7SAKMA1](#)
[DMN2990UFB-7B](#) [SSM3K35CT,L3F](#) [IPLK60R1K0PFD7ATMA1](#) [2N7002W-G](#) [MCAC30N06Y-TP](#) [IPWS65R035CFD7AXKSA1](#)
[MCQ7328-TP](#) [SSM3J143TU,LXHF](#) [DMN12M3UCA6-7](#) [PJMF280N65E1_T0_00201](#) [PJMF380N65E1_T0_00201](#)
[PJMF280N60E1_T0_00201](#) [PJMF600N65E1_T0_00201](#) [PJMF900N65E1_T0_00201](#)