

Applications

- Synchronous MOSFET for Notebook Processor Power
- Synchronous Rectifier MOSFET for Isolated DC-DC Converters in Networking Systems

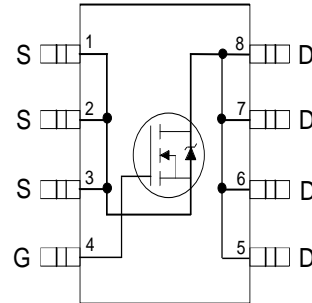

Benefits

- Very Low $R_{DS(on)}$ at 4.5V V_{GS}
- Low Gate Charge
- Fully Characterized Avalanche Voltage and Current
- $V_{DS}(V) = 30V$
- $I_D = 17.2A$ ($V_{GS} = 10V$)
- $R_{DS(ON)} < 5.6m\Omega$ ($V_{GS} = 10V$)
- $R_{DS(ON)} < 6.8m\Omega$ ($V_{GS} = 4.5V$)

Absolute Maximum Ratings

	Parameter	Max.	Units
V_{DS}	Drain-to-Source Voltage	30	V
V_{GS}	Gate-to-Source Voltage	± 20	
$I_D @ T_A = 25^\circ C$	Continuous Drain Current, $V_{GS} @ 10V$	17.2	A
$I_D @ T_A = 70^\circ C$	Continuous Drain Current, $V_{GS} @ 10V$	13.8	
I_{DM}	Pulsed Drain Current ①	135	
$P_D @ T_A = 25^\circ C$	Power Dissipation ④	2.5	W
$P_D @ T_A = 70^\circ C$	Power Dissipation ④	1.6	
	Linear Derating Factor	0.02	W/°C
T_J	Operating Junction and	-55 to + 150	°C
T_{STG}	Storage Temperature Range		

Thermal Resistance

	Parameter	Typ.	Max.	Units
$R_{\theta JL}$	Junction-to-Drain Lead ⑤		20	°C/W
$R_{\theta JA}$	Junction-to-Ambient ④⑤		50	

Static @ T_J = 25°C (unless otherwise specified)

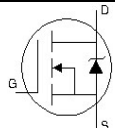
	Parameter	Min.	Typ.	Max.	Units	Conditions	
BV _{DSS}	Drain-to-Source Breakdown Voltage	30			V	V _{GS} = 0V, I _D = 250μA	
ΔBV _{DSS} /ΔT _J	Breakdown Voltage Temp. Coefficient		0.024		V/°C	Reference to 25°C, I _D = 1mA	
R _{DS(on)}	Static Drain-to-Source On-Resistance		4.7	5.6	mΩ	V _{GS} = 10V, I _D = 17.2A ③	
			5.8	6.8		V _{GS} = 4.5V, I _D = 13.8A ③	
V _{GS(th)}	Gate Threshold Voltage	1.5		2.2	V	V _{DS} = V _{GS} , I _D = 250μA	
ΔV _{GS(th)}	Gate Threshold Voltage Coefficient		- 5.4		mV/°C		
I _{DSS}	Drain-to-Source Leakage Current			1.0	μA	V _{DS} = 24V, V _{GS} = 0V	
				150		V _{DS} = 24V, V _{GS} = 0V, T _J = 125°C	
I _{GSS}	Gate-to-Source Forward Leakage			100	nA	V _{GS} = 20V	
	Gate-to-Source Reverse Leakage			-100		V _{GS} = -20V	
g _{fs}	Forward Transconductance	73			S	V _{DS} = 15V, I _D = 13.3A	
Q _g	Total Gate Charge		24	36	nC	V _{DS} = 15V V _{GS} = 4.5V I _D = 13.3A See Fig. 16	
Q _{gs1}	Pre-V _{th} Gate-to-Source Charge		6.2				
Q _{gs2}	Post-V _{th} Gate-to-Source Charge		2.0				
Q _{gd}	Gate-to-Drain Charge		8.5				
Q _{godr}	Gate Charge Overdrive		7.3				
Q _{sw}	Switch Charge (Q _{gs2} + Q _{gd})		10.5				
Q _{oss}	Output Charge		10				
t _{d(on)}	Turn-On Delay Time		13		ns	V _{DD} = 15V, V _{GS} = 4.5V ③ I _D = 13.3A Clamped Inductive Load	
t _r	Rise Time		8.9				
t _{d(off)}	Turn-Off Delay Time		17				
t _f	Fall Time		3.5				
C _{iss}	Input Capacitance		2910		pF	V _{GS} = 0V V _{DS} = 15V f = 1.0MHz	
C _{oss}	Output Capacitance		600				
C _{rss}	Reverse Transfer Capacitance		250				
	Parameter		Typ.			Max.	Units
E _{AS}	Single Pulse Avalanche Energy ②					48	mJ
I _{AR}	Avalanche Current ①					13.3	A
	Parameter	Min.	Typ.	Max.	Units	Conditions	
I _S	Continuous Source Current (Body Diode)			3.1	A	MOSFET symbol showing the integral reverse p-n junction diode. 	
I _{SM}	Pulsed Source Current (Body Diode) ①			135			
V _{SD}	Diode Forward Voltage			1.0	V	T _J = 25°C, I _S = 13.3A, V _{GS} = 0V ③	
t _{rr}	Reverse Recovery Time		34	51	ns	T _J = 25°C, I _F = 13.3A, V _{DD} = 10V	
Q _{rr}	Reverse Recovery Charge		21	32	nC	di/dt = 100A/μs ③	

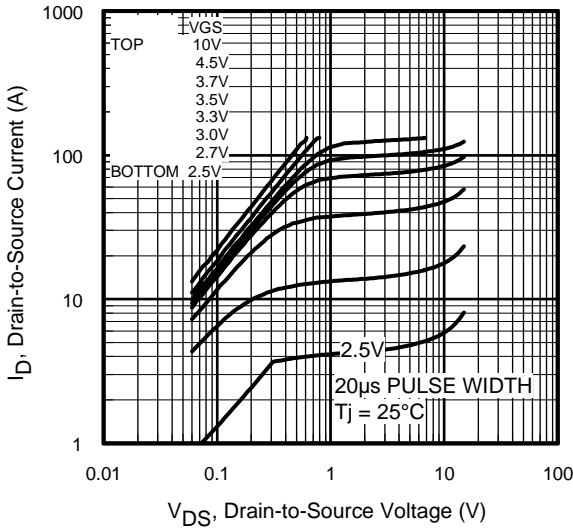

Fig 1. Typical Output Characteristics

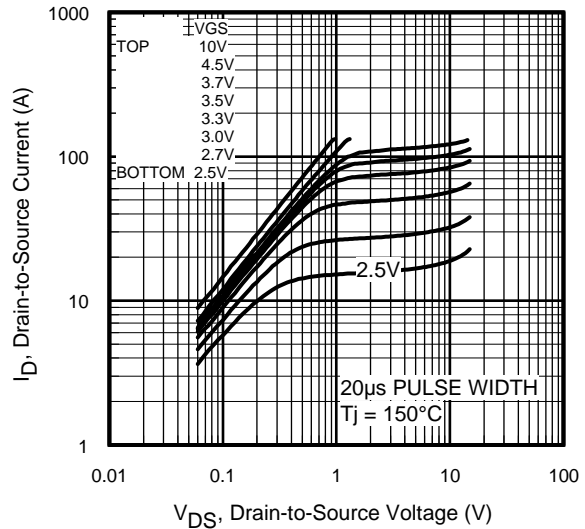

Fig 2. Typical Output Characteristics

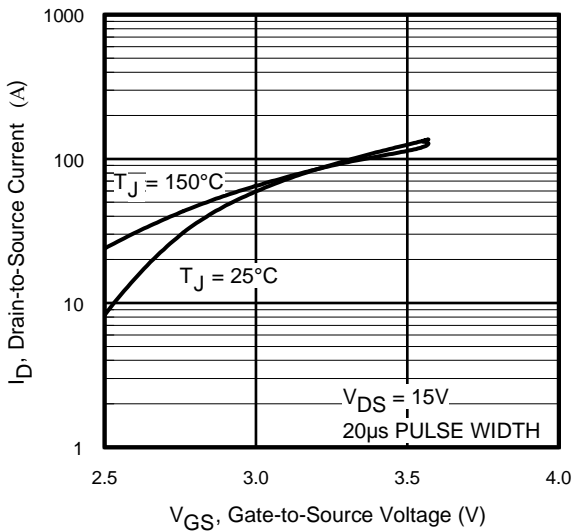

Fig 3. Typical Transfer Characteristics

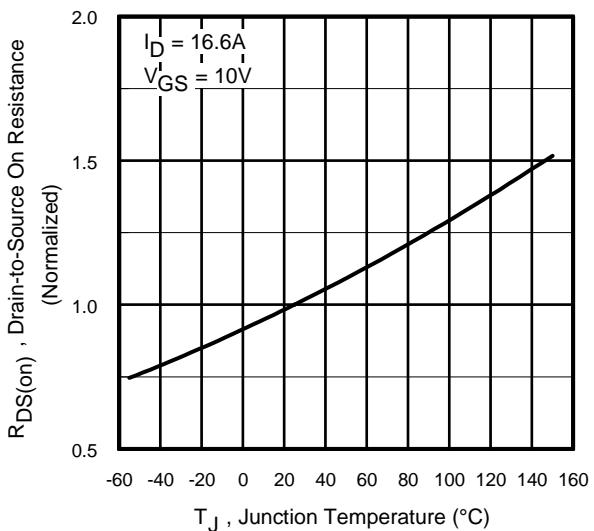

Fig 4. Normalized On-Resistance Vs. Temperature

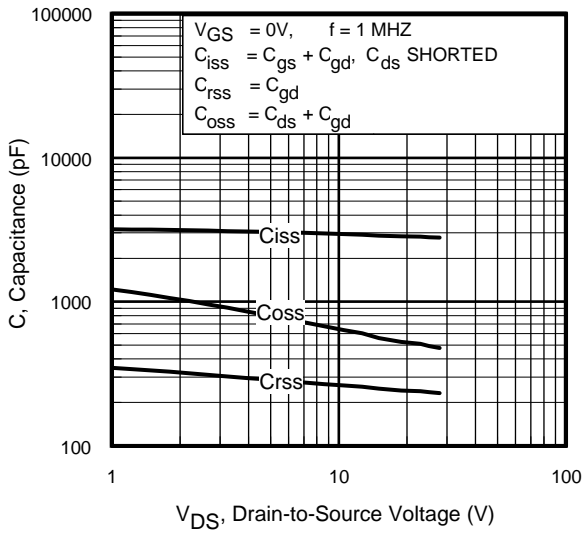

Fig 5. Typical Capacitance Vs. Drain-to-Source Voltage

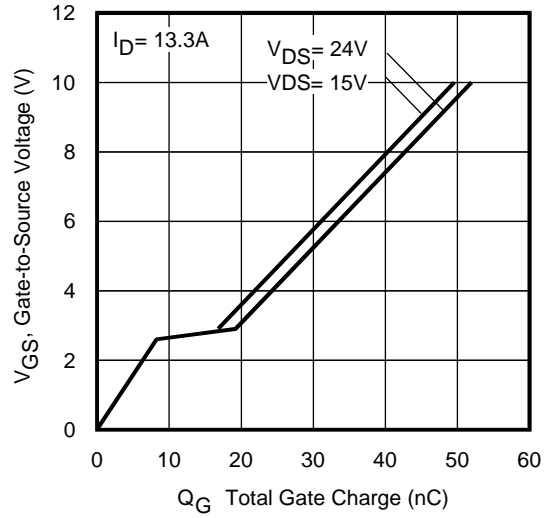

Fig 6. Typical Gate Charge Vs. Gate-to-Source Voltage

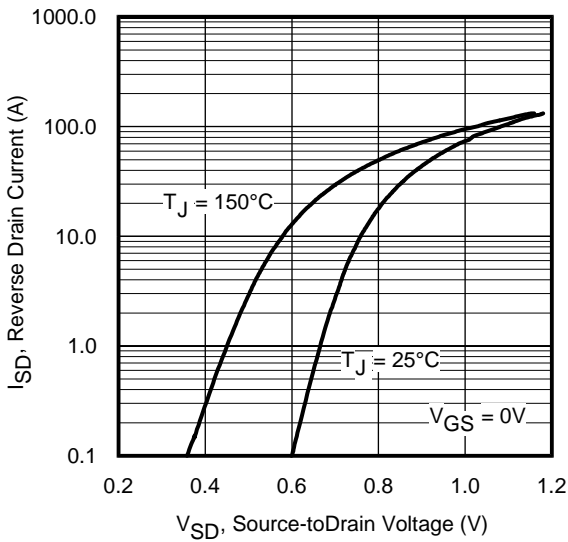

Fig 7. Typical Source-Drain Diode Forward Voltage

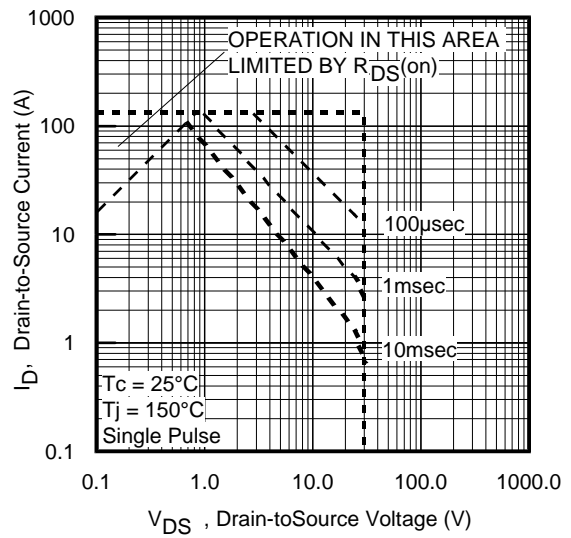

Fig 8. Maximum Safe Operating Area

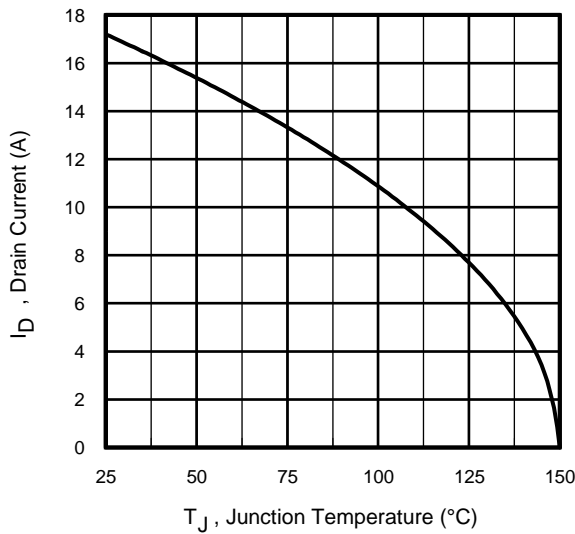

Fig 9. Maximum Drain Current Vs. Case Temperature

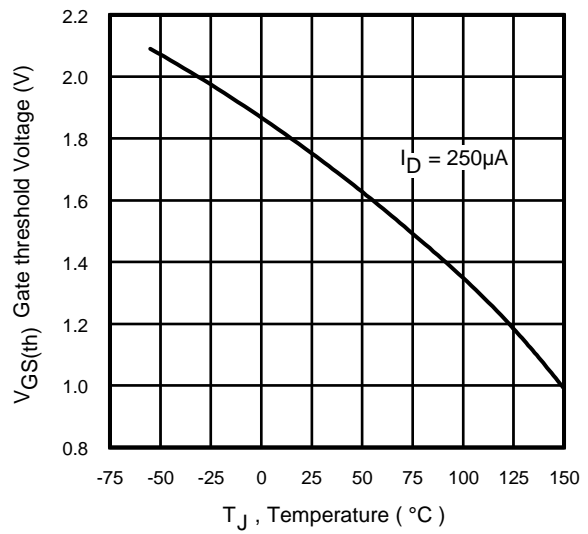

Fig 10. Threshold Voltage Vs. Temperature

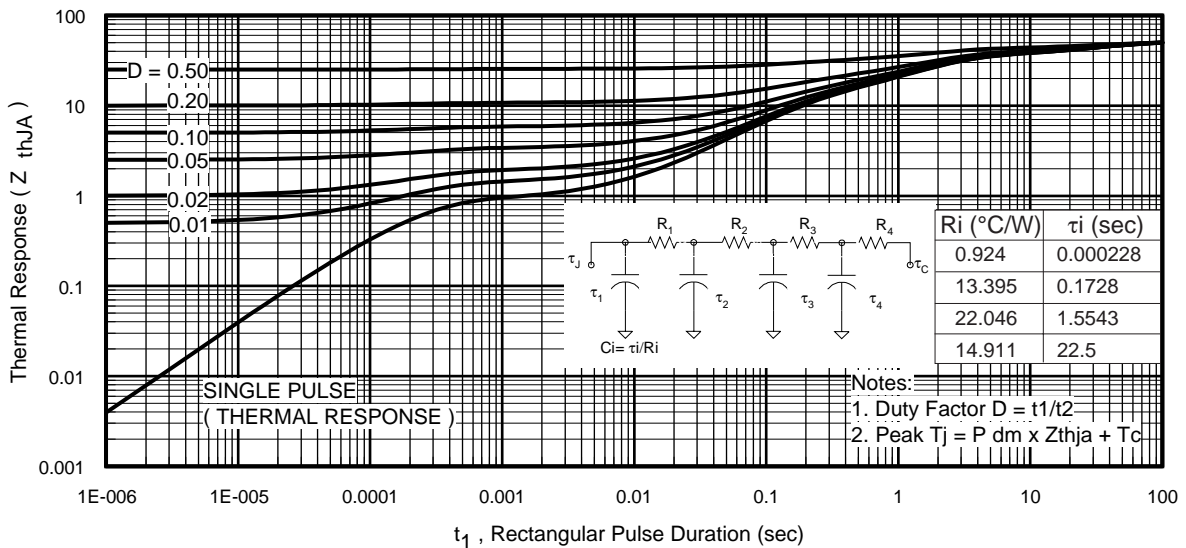

Fig 11. Maximum Effective Transient Thermal Impedance, Junction-to-Ambient

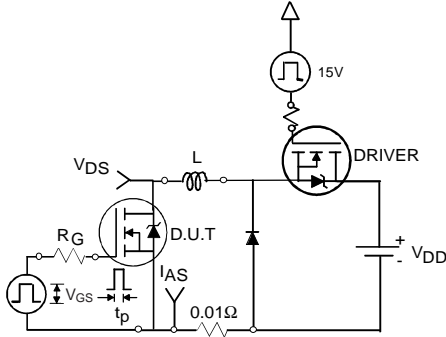

Fig 12a. Unclamped Inductive Test Circuit

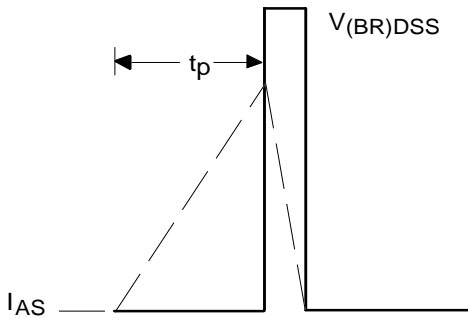

Fig 12b. Unclamped Inductive Waveforms

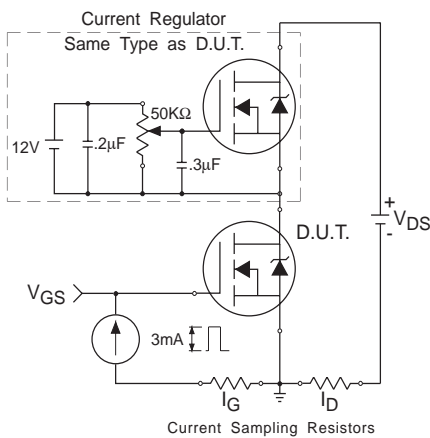

Fig 13. Gate Charge Test Circuit

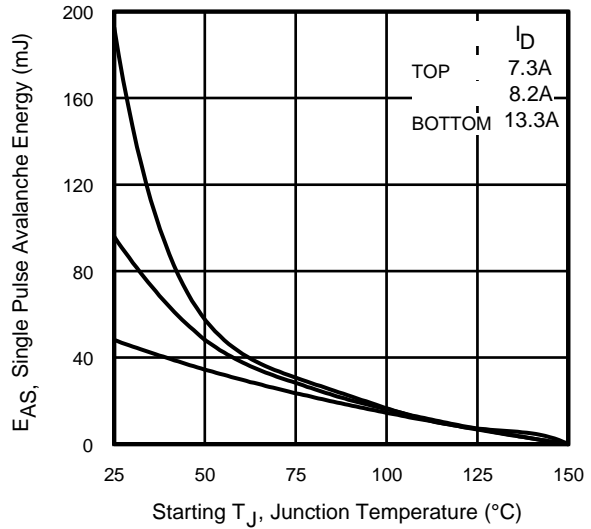

Fig 12c. Maximum Avalanche Energy Vs. Drain Current

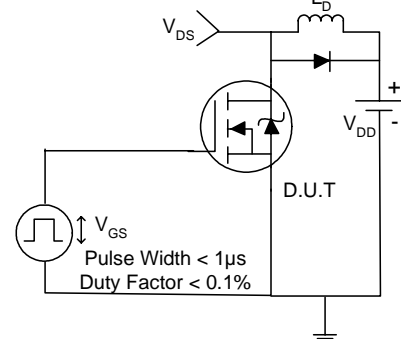

Fig 14a. Switching Time Test Circuit

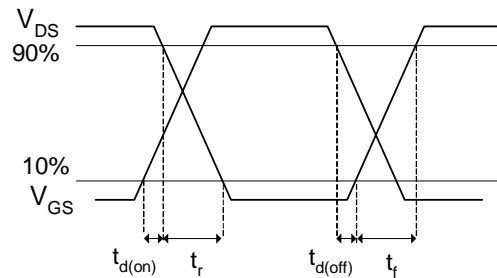
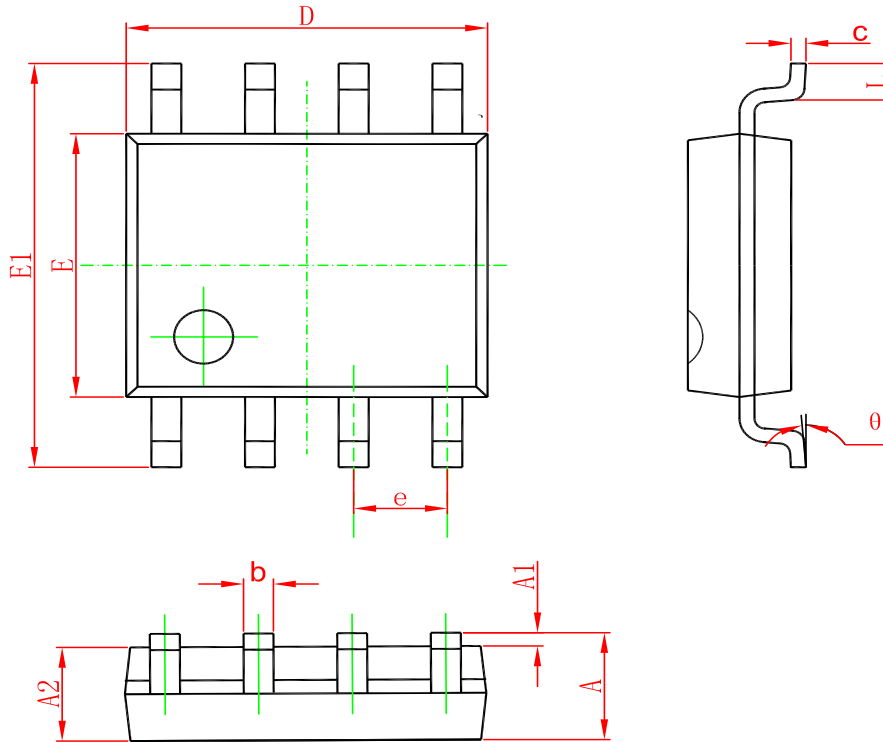

Fig 14b. Switching Time Waveforms

PACKAGE OUTLINE DIMENSIONS

SOP-8



Symbol	Dimensions In Millimeters		Dimensions In Inches	
	Min	Max	Min	Max
A	1.350	1.750	0.053	0.069
A1	0.100	0.250	0.004	0.010
A2	1.350	1.550	0.053	0.061
b	0.330	0.510	0.013	0.020
c	0.170	0.250	0.006	0.010
D	4.700	5.100	0.185	0.200
E	3.800	4.000	0.150	0.157
E1	5.800	6.200	0.228	0.244
e	1.270(BSC)		0.050(BSC)	
L	0.400	1.270	0.016	0.050
θ	0°	8°	0°	8°

Marking

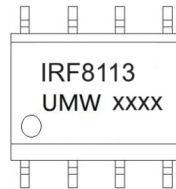

Ordering information

Order code	Package	Baseqty	Deliverymode
UMW IRF8113TR	SOP-8	3000	Tape and reel

X-ON Electronics

Largest Supplier of Electrical and Electronic Components

Click to view similar products for [MOSFET](#) category:

Click to view products by [Youtai](#) manufacturer:

Other Similar products are found below :

[IRFD120](#) [JANTX2N5237](#) [2SK2267\(Q\)](#) [BUK455-60A/B](#) [TK100A10N1,S4X\(S](#) [MIC4420CM-TR](#) [VN1206L](#) [NDP4060](#) [SI4482DY](#)
[IRS2092STRPBF-EL](#) [IPS70R2K0CEAKMA1](#) [TK31J60W5,S1VQ\(O](#) [TK31J60W,S1VQ\(O](#) [TK16J60W,S1VQ\(O](#) [2SK2614\(TE16L1,Q\)](#)
[DMN1017UCP3-7](#) [EFC2J004NUZTDG](#) [P85W28HP2F-7071](#) [DMN1053UCP4-7](#) [NTE2384](#) [DMC2700UDMQ-7](#) [DMN2080UCB4-7](#)
[DMN61D9UWQ-13](#) [US6M2GTR](#) [DMN31D5UDJ-7](#) [DMP22D4UFO-7B](#) [IPS60R3K4CEAKMA1](#) [DMN1006UCA6-7](#) [DMN16M9UCA6-7](#)
[STF5N65M6](#) [IRF40H233XTMA1](#) [STU5N65M6](#) [DMN6022SSD-13](#) [DMN13M9UCA6-7](#) [DMTH10H4M6SPS-13](#) [IPS60R360PFD7SAKMA1](#)
[DMN2990UFB-7B](#) [SSM3K35CT,L3F](#) [IPLK60R1K0PFD7ATMA1](#) [2N7002W-G](#) [MCAC30N06Y-TP](#) [IPWS65R035CFD7AXKSA1](#)
[MCQ7328-TP](#) [SSM3J143TU,LXHF](#) [DMN12M3UCA6-7](#) [PJMF280N65E1_T0_00201](#) [PJMF380N65E1_T0_00201](#)
[PJMF280N60E1_T0_00201](#) [PJMF600N65E1_T0_00201](#) [PJMF900N65E1_T0_00201](#)