

Description

The UMW IRF8707TR has been optimized for parameters that are critical in synchronous buck operation including $R_{ds(on)}$ and gate charge to reduce both conduction and switching losses. The reduced total losses make this product ideal for high efficiency DC-DC converters that power the latest generation of processors for notebook and Netcom applications.

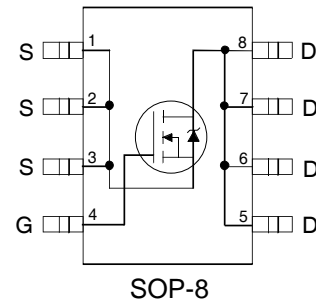

Applications

- Control MOSFET of Sync-Buck Converters used for Notebook Processor Power
- Control MOSFET for Isolated DC-DC Converters in Networking Systems

Benefits

- Very Low Gate Charge
- Very Low $R_{DS(on)}$ at 4.5V V_{GS}
- Ultra-Low Gate Impedance
- 20V V_{GS} Max. Gate Rating
- $V_{DS}(V) = 30V$
- $I_D = 11A$ ($V_{GS} = 10V$)
- $R_{DS(ON)} < 11.9m\Omega$ ($V_{GS} = 10V$)
- $R_{DS(ON)} < 17.5m\Omega$ ($V_{GS} = 4.5V$)

Absolute Maximum Ratings

	Parameter	Max.	Units
V_{DS}	Drain-to-Source Voltage	30	V
V_{GS}	Gate-to-Source Voltage	± 20	
$I_D @ T_A = 25^\circ C$	Continuous Drain Current, $V_{GS} @ 10V$	11	A
$I_D @ T_A = 70^\circ C$	Continuous Drain Current, $V_{GS} @ 10V$	9.1	
I_{DM}	Pulsed Drain Current ①	88	
$P_D @ T_A = 25^\circ C$	Power Dissipation	2.5	W
$P_D @ T_A = 70^\circ C$	Power Dissipation	1.6	
	Linear Derating Factor	0.02	W/ $^\circ C$
T_J	Operating Junction and	-55 to + 150	$^\circ C$
T_{STG}	Storage Temperature Range		

Thermal Resistance

	Parameter	Typ.	Max.	Units
$R_{\theta JL}$	Junction-to-Drain Lead ⑤		20	$^\circ C/W$
$R_{\theta JA}$	Junction-to-Ambient ④⑤		50	

Notes ① through ⑤ are on page 9

Static @ T_J = 25°C (unless otherwise specified)

	Parameter	Min.	Typ.	Max.	Units	Conditions	
BV _{DSS}	Drain-to-Source Breakdown Voltage	30			V	V _{GS} = 0V, I _D = 250μA	
ΔBV _{DSS} /ΔT _J	Breakdown Voltage Temp. Coefficient		0.022		V/°C	Reference to 25°C, I _D = 1mA	
R _{DS(on)}	Static Drain-to-Source On-Resistance		9.3	11.9	mΩ	V _{GS} = 10V, I _D = 11A ③	
			14.2	17.5		V _{GS} = 4.5V, I _D = 8.8A ③	
V _{GS(th)}	Gate Threshold Voltage	1.35	1.80	2.35	V	V _{DS} = V _{GS} , I _D = 25μA	
ΔV _{GS(th)}	Gate Threshold Voltage Coefficient		-5.8		mV/°C	V _{DS} = V _{GS} , I _D = 25μA	
I _{DSS}	Drain-to-Source Leakage Current			1.0	μA	V _{DS} = 24V, V _{GS} = 0V	
				150		V _{DS} = 24V, V _{GS} = 0V, T _J = 125°C	
I _{GSS}	Gate-to-Source Forward Leakage			100	nA	V _{GS} = 20V	
	Gate-to-Source Reverse Leakage			-100		V _{GS} = -20V	
g _{fs}	Forward Transconductance	25			S	V _{DS} = 15V, I _D = 8.8A	
Q _g	Total Gate Charge		6.2	9.3	nC	V _{DS} = 15V V _{GS} = 4.5V I _D = 8.8A See Figs. 15 & 16	
Q _{gs1}	Pre-V _{th} Gate-to-Source Charge		1.4				
Q _{gs2}	Post-V _{th} Gate-to-Source Charge		0.7				
Q _{gd}	Gate-to-Drain Charge		2.2				
Q _{godr}	Gate Charge Overdrive		1.9				
Q _{sw}	Switch Charge (Q _{gs2} + Q _{gd})		2.9				
Q _{oss}	Output Charge		3.7				nC
R _g	Gate Resistance		2.2	3.7	Ω		
t _{d(on)}	Turn-On Delay Time		6.7		ns	V _{DD} = 15V, V _{GS} = 4.5V I _D = 8.8A R _G = 1.8Ω See Fig. 18	
t _r	Rise Time		7.9				
t _{d(off)}	Turn-Off Delay Time		7.3				
t _f	Fall Time		4.4				
C _{iss}	Input Capacitance		760		pF	V _{GS} = 0V V _{DS} = 15V f = 1.0MHz	
C _{oss}	Output Capacitance		170				
C _{rss}	Reverse Transfer Capacitance		82				
	Parameter		Typ.			Max.	Units
E _{AS}	Single Pulse Avalanche Energy ②					53	mJ
I _{AR}	Avalanche Current ①					8.8	A
	Parameter	Min.	Typ.	Max.	Units	Conditions	
I _S	Continuous Source Current (Body Diode)			3.1	A	MOSFET symbol showing the integral reverse p-n junction diode.	
I _{SM}	Pulsed Source Current (Body Diode) ①			88	A		
V _{SD}	Diode Forward Voltage			1.0	V	T _J = 25°C, I _S = 8.8A, V _{GS} = 0V ③	
t _{rr}	Reverse Recovery Time		12	18	ns	T _J = 25°C, I _F = 8.8A, V _{DD} = 15V	
Q _{rr}	Reverse Recovery Charge		13	20	nC	di/dt = 300A/ s ③	
t _{on}	Forward Turn-On Time	Intrinsic turn-on time is negligible (turn-on is dominated by LS+LD)					

Notes:

- ① Repetitive rating; pulse width limited by max. junction temperature.
- ② Starting T_J = 25°C, L = 1.38mH, R_G = 25Ω, I_{AS} = 8.8A.
- ③ Pulse width ≤ 400μs; duty cycle ≤ 2%.
- ④ When mounted on 1 inch square copper board.
- ⑤ R_g is measured at T_J of approximately 90°C.

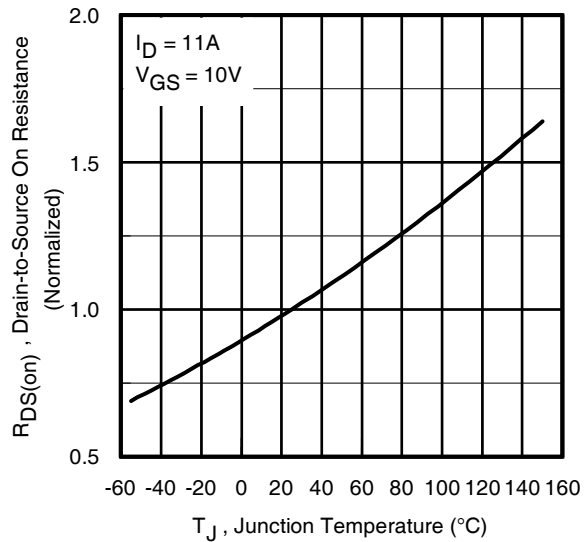
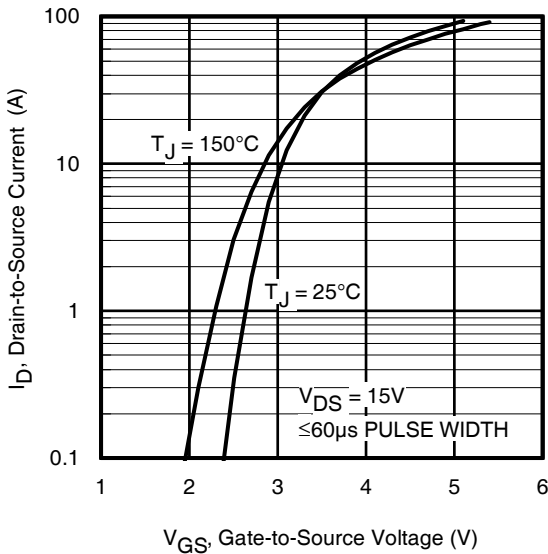
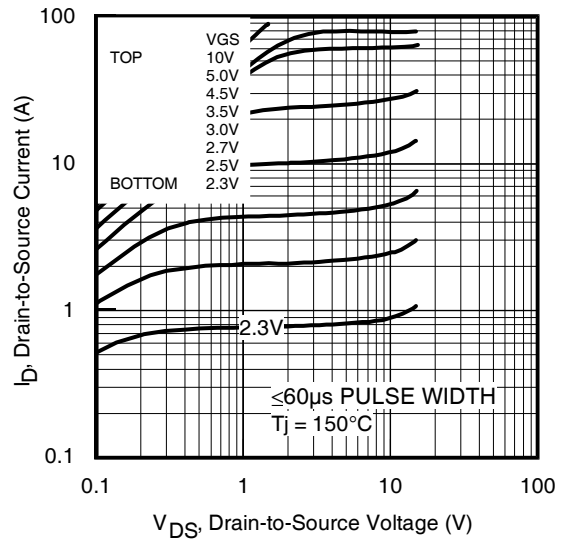
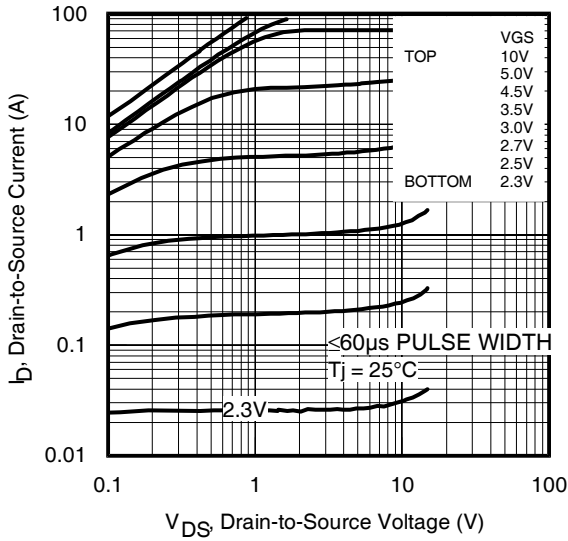

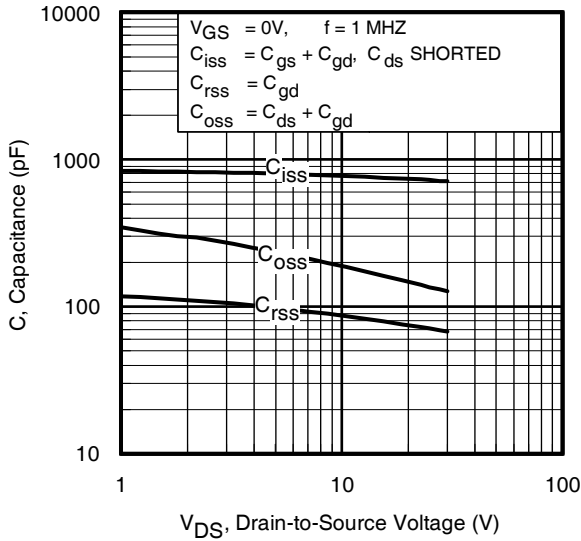

Fig 5. Typical Capacitance vs. Drain-to-Source Voltage

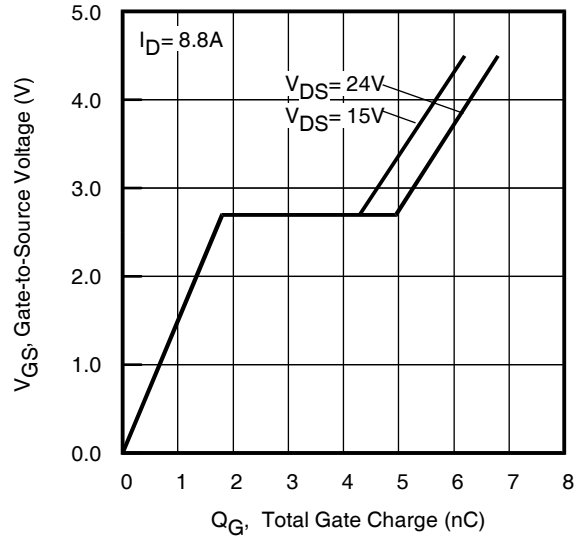

Fig 6. Typical Gate Charge Vs. Gate-to-Source Voltage

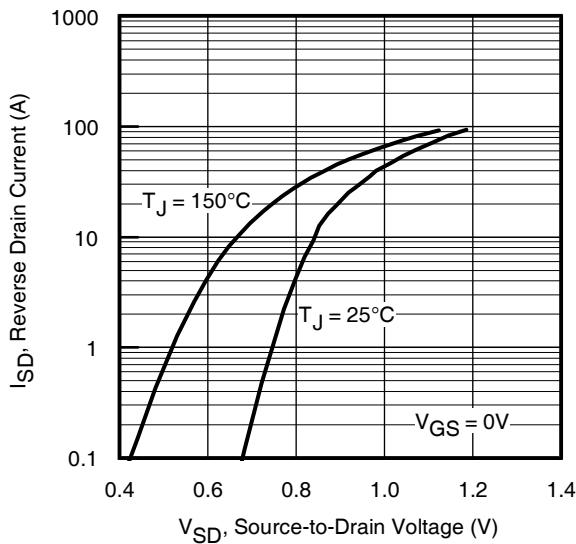

Fig 7. Typical Source-Drain Diode Forward Voltage

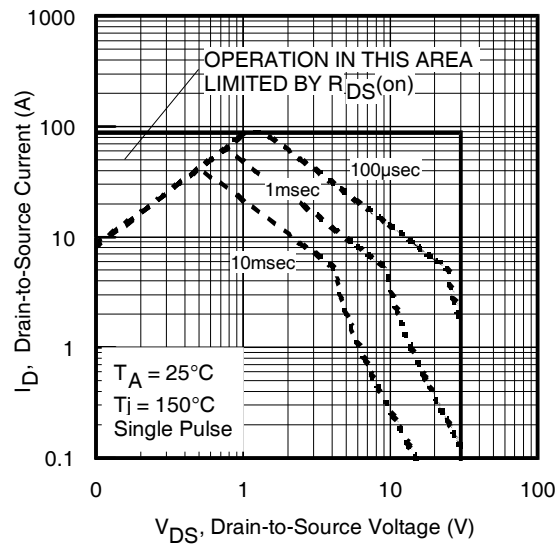

Fig 8. Maximum Safe Operating Area

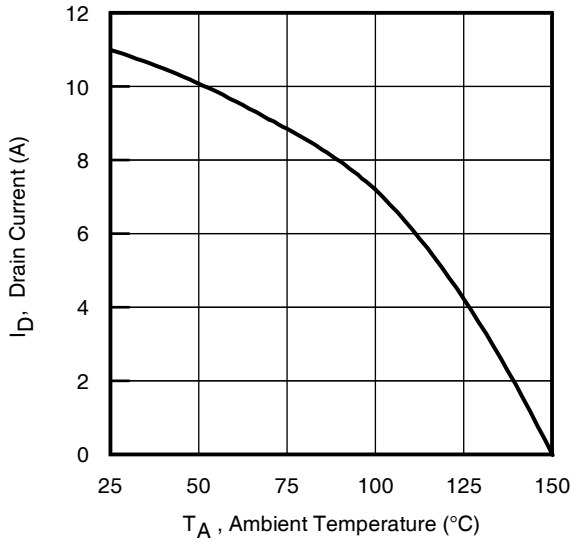

Fig 9. Maximum Drain Current vs. Ambient Temperature

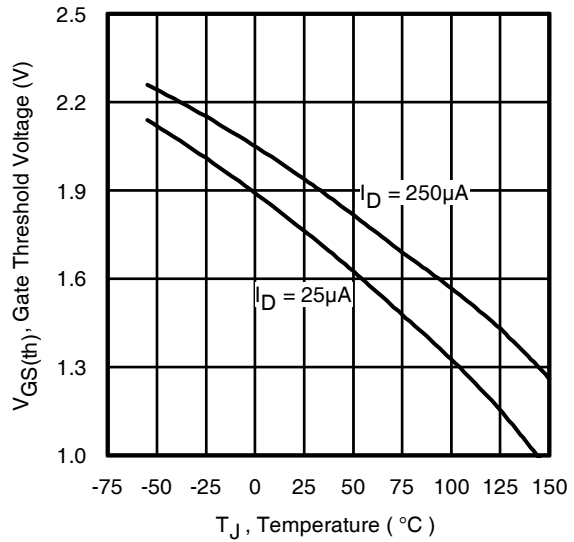

Fig 10. Threshold Voltage vs. Temperature

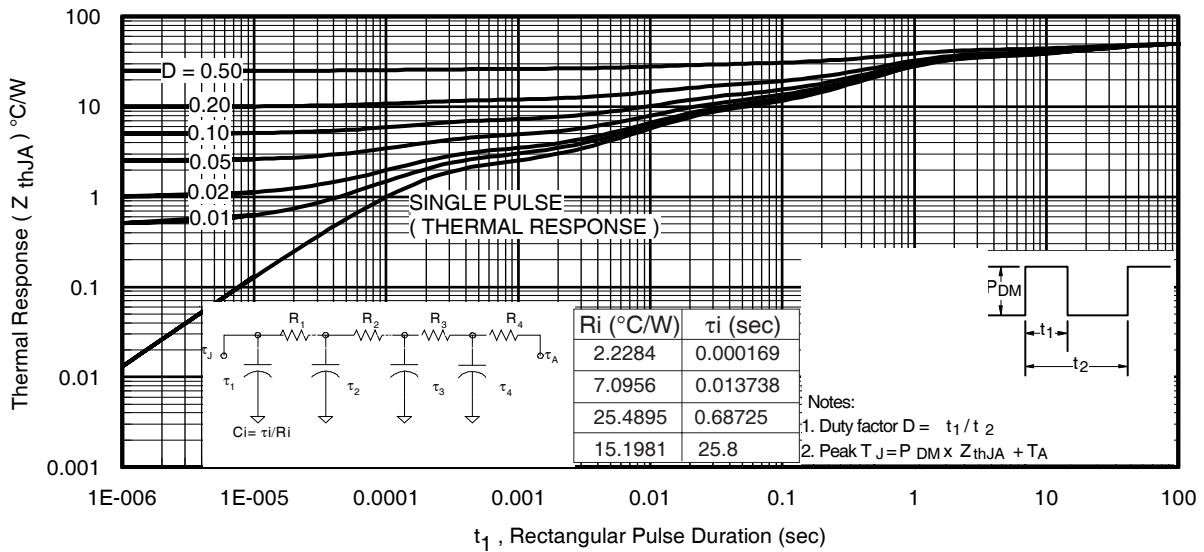

Fig 11. Maximum Effective Transient Thermal Impedance, Junction-to-Ambient

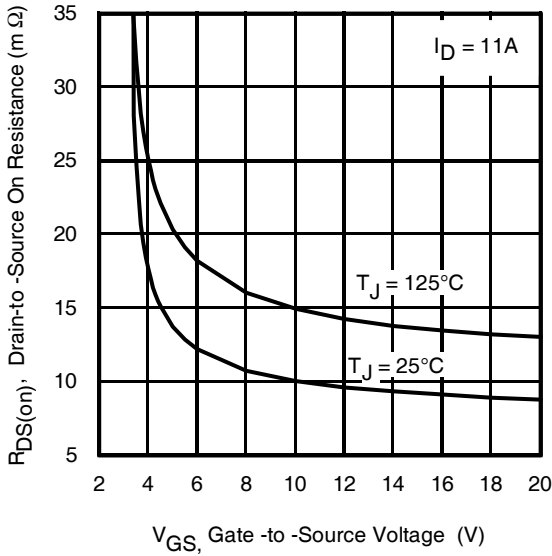

Fig 12. On-Resistance vs. Gate Voltage

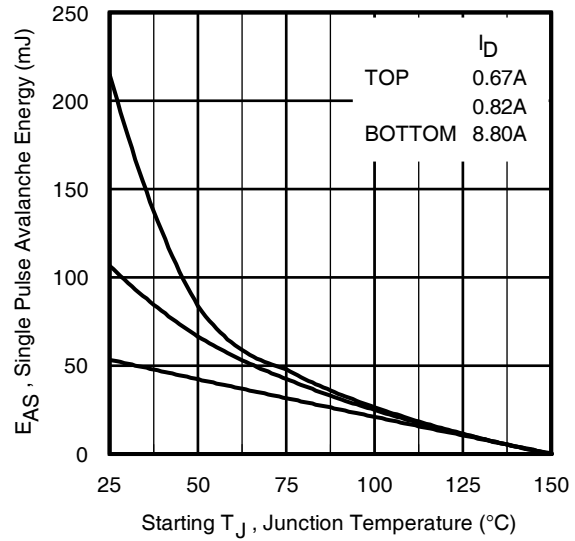

Fig 13. Maximum Avalanche Energy vs. Drain Current

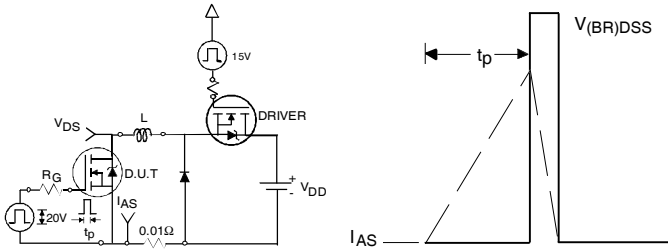

Fig 14. Unclamped Inductive Test Circuit and Waveform

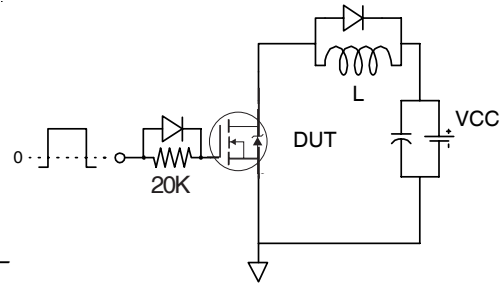

Fig 15. Gate Charge Test Circuit



Fig 16. Gate Charge Waveform

PACKAGE OUTLINE DIMENSIONS

SOP-8

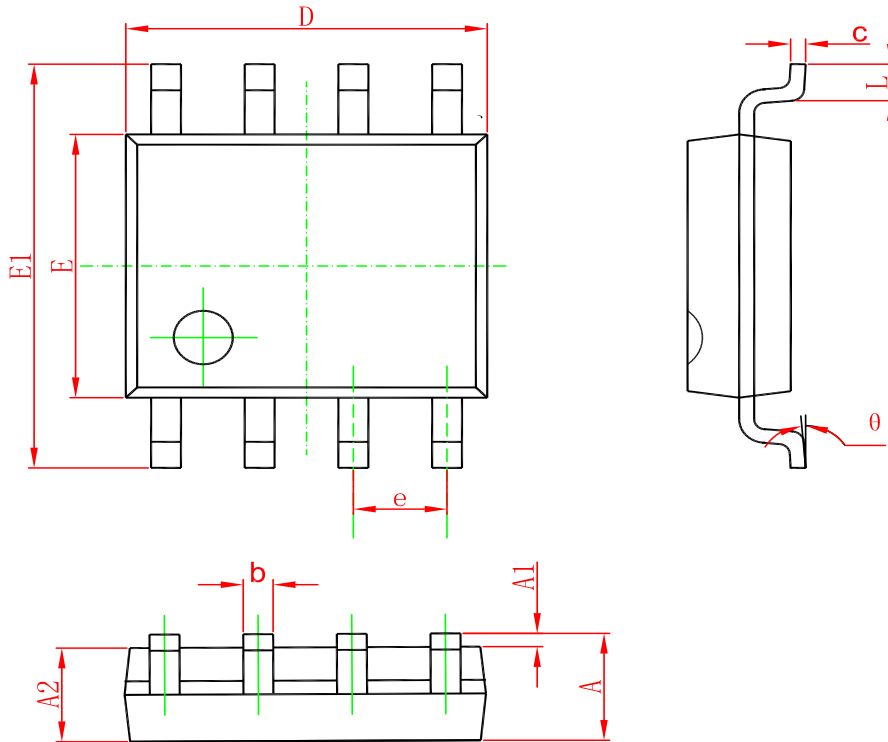

Symbol	Dimensions In Millimeters		Dimensions In Inches	
	Min	Max	Min	Max
A	1.350	1.750	0.053	0.069
A1	0.100	0.250	0.004	0.010
A2	1.350	1.550	0.053	0.061
b	0.330	0.510	0.013	0.020
c	0.170	0.250	0.006	0.010
D	4.700	5.100	0.185	0.200
E	3.800	4.000	0.150	0.157
E1	5.800	6.200	0.228	0.244
e	1.270(BSC)		0.050(BSC)	
L	0.400	1.270	0.016	0.050
θ	0°	8°	0°	8°

Marking

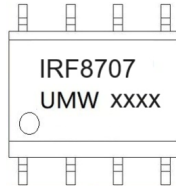

Ordering information

Order code	Package	Baseqty	Deliverymode
UMW IRF8707TR	SOP-8	3000	Tape and reel

X-ON Electronics

Largest Supplier of Electrical and Electronic Components

Click to view similar products for [MOSFET](#) category:

Click to view products by [Youtai](#) manufacturer:

Other Similar products are found below :

[IRFD120](#) [JANTX2N5237](#) [2SK2267\(Q\)](#) [BUK455-60A/B](#) [TK100A10N1,S4X\(S](#) [MIC4420CM-TR](#) [VN1206L](#) [NDP4060](#) [SI4482DY](#)
[IRS2092STRPBF-EL](#) [IPS70R2K0CEAKMA1](#) [TK31J60W5,S1VQ\(O](#) [TK31J60W,S1VQ\(O](#) [TK16J60W,S1VQ\(O](#) [2SK2614\(TE16L1,Q\)](#)
[DMN1017UCP3-7](#) [EFC2J004NUZTDG](#) [P85W28HP2F-7071](#) [DMN1053UCP4-7](#) [NTE2384](#) [DMC2700UDMQ-7](#) [DMN2080UCB4-7](#)
[DMN61D9UWQ-13](#) [US6M2GTR](#) [DMN31D5UDJ-7](#) [DMP22D4UFO-7B](#) [IPS60R3K4CEAKMA1](#) [DMN1006UCA6-7](#) [DMN16M9UCA6-7](#)
[STF5N65M6](#) [IRF40H233XTMA1](#) [STU5N65M6](#) [DMN6022SSD-13](#) [DMN13M9UCA6-7](#) [DMTH10H4M6SPS-13](#) [IPS60R360PFD7SAKMA1](#)
[DMN2990UFB-7B](#) [SSM3K35CT,L3F](#) [IPLK60R1K0PFD7ATMA1](#) [2N7002W-G](#) [MCAC30N06Y-TP](#) [IPWS65R035CFD7AXKSA1](#)
[MCQ7328-TP](#) [SSM3J143TU,LXHF](#) [DMN12M3UCA6-7](#) [PJMF280N65E1_T0_00201](#) [PJMF380N65E1_T0_00201](#)
[PJMF280N60E1_T0_00201](#) [PJMF600N65E1_T0_00201](#) [PJMF900N65E1_T0_00201](#)