

General Description

This device employs a new advanced trench technology and features low gate charge while maintaining low on-resistance. Optimized for switching applications, this device improves the overall efficiency of DC/DC converters and allows operation to higher switching frequencies.

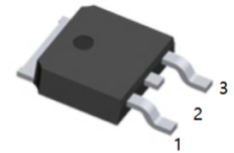

1.G 2.D 3.S
TO-252(DPAK) top view

Applications

- DC/DC converters

Features

- $V_{DS}(V) = 30V$
- $I_D = 50A$ ($V_{GS} = 10V$)
- $R_{DS(ON)} < 5.2m\Omega$ ($V_{GS} = 10V$)
- $R_{DS(ON)} < 8.5m\Omega$ ($V_{GS} = 4.5V$)
- Q_g (Typ) = 30nC, $V_{GS} = 5V$
- Q_{gd} (Typ) = 11nC
- C_{ISS} (Typ) = 3400pF

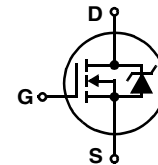

MOSFET Maximum Ratings $T_A = 25^\circ C$ unless otherwise noted

Symbol	Parameter	Ratings	Units
V_{DSS}	Drain to Source Voltage	30	V
V_{GS}	Gate to Source Voltage	± 20	V
I_D	Drain Current		
	Continuous ($T_C = 25^\circ C, V_{GS} = 10V$)	50	A
	Continuous ($T_C = 100^\circ C, V_{GS} = 4.5V$)	50	A
	Continuous ($T_C = 25^\circ C, V_{GS} = V, R_{\theta JC} = 52^\circ C/W$)	16	A
	Pulsed	Figure 4	A
P_D	Power dissipation	125	W
	Derate above $25^\circ C$	0.83	W/ $^\circ C$
T_J, T_{STG}	Operating and Storage Temperature	-55 to 175	$^\circ C$

Thermal Characteristics

$R_{\theta JC}$	Thermal Resistance Junction to Case TO-252	1.2	$^\circ C/W$
$R_{\theta JA}$	Thermal Resistance Junction to Ambient TO-252	100	$^\circ C/W$
$R_{\theta JA}$	Thermal Resistance Junction to Ambient TO-252, 1in ² copper pad area	52	$^\circ C/W$

Electrical Characteristics $T_A = 25^\circ\text{C}$ unless otherwise noted

Symbol	Parameter	Test Conditions	Min	Typ	Max	Units	
B_{VDSS}	Drain to Source Breakdown Voltage	$I_D = 250\mu\text{A}, V_{GS} = 0\text{V}$	30			V	
I_{DSS}	Zero Gate Voltage Drain Current	$V_{DS} = 25\text{V}$			1	μA	
I_{GSS}	Gate to Source Leakage Current	$V_{GS} = \pm 20\text{V}$			± 100	nA	
$V_{GS(TH)}$	Gate to Source Threshold Voltage	$V_{GS} = V_{DS}, I_D = 250\mu\text{A}$	1		3	V	
$r_{DS(ON)}$	Drain to Source On Resistance	$I_D = 50\text{A}, V_{GS} = 10\text{V}$		5.2	6	m Ω	
		$I_D = 50\text{A}, V_{GS} = 4.5\text{V}$		8.5	9.5		
C_{ISS}	Input Capacitance	$V_{DS} = 15\text{V}, V_{GS} = 0\text{V}, f = 1\text{MHz}$		3400		pF	
C_{OSS}	Output Capacitance			650		pF	
C_{RSS}	Reverse Transfer Capacitance			300		pF	
$Q_{g(TOT)}$	Total Gate Charge at 10V		$V_{GS} = 0\text{V to } 10\text{V}$		60	90	nC
$Q_{g(5)}$	Total Gate Charge at 5V	$V_{GS} = 0\text{V to } 5\text{V}$	$V_{DD} = 15\text{V}$ $I_D = 50\text{A}$ $I_g = 1.0\text{mA}$		30	45	nC
$Q_{g(TH)}$	Threshold Gate Charge	$V_{GS} = 0\text{V to } 1\text{V}$			3.0	4.5	nC
Q_{gs}	Gate to Source Gate Charge				10		nC
Q_{gd}	Gate to Drain "Miller" Charge				11		nC
t_{ON}	Turn-On Time	$V_{DD} = 15\text{V}, I_D = 16\text{A}$ $V_{GS} = 4.5\text{V}, R_{GS} = 4.3\Omega$			131	ns	
$t_{d(ON)}$	Turn-On Delay Time			16		ns	
t_r	Rise Time			70		ns	
$t_{d(OFF)}$	Turn-Off Delay Time			34		ns	
t_f	Fall Time			30		ns	
t_{OFF}	Turn-Off Time				97	ns	
t_{ON}	Turn-On Time		$V_{DD} = 15\text{V}, I_D = 16\text{A}$ $V_{GS} = 10\text{V}, R_{GS} = 4.3\Omega$			80	ns
$t_{d(ON)}$	Turn-On Delay Time			10		ns	
t_r	Rise Time			43		ns	
$t_{d(OFF)}$	Turn-Off Delay Time			62		ns	
t_f	Fall Time			29		ns	
t_{OFF}	Turn-Off Time				137	ns	
t_{AV}	Avalanche Time	$I_D = 30\text{A}, L = 200\mu\text{H}$		428			μs
V_{SD}	Source to Drain Diode Voltage	$I_{SD} = 50\text{A}$			1.25	V	
		$I_{SD} = 25\text{A}$			1.0	V	
t_{rr}	Reverse Recovery Time	$I_{SD} = 50\text{A}, dI_{SD}/dt = 100\text{A}/\mu\text{s}$			35	ns	
Q_{RR}	Reverse Recovered Charge	$I_{SD} = 50\text{A}, dI_{SD}/dt = 100\text{A}/\mu\text{s}$			30	nC	

Typical Characteristic

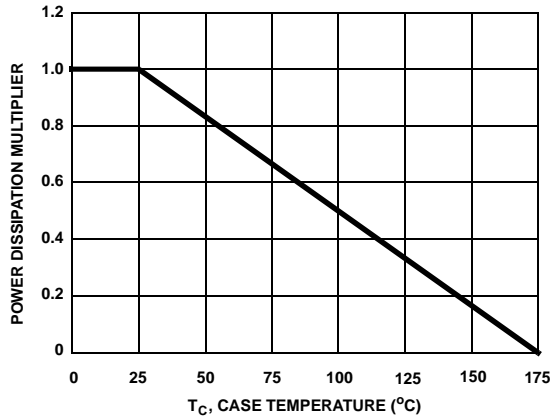

Figure 1. Normalized Power Dissipation vs Ambient Temperature

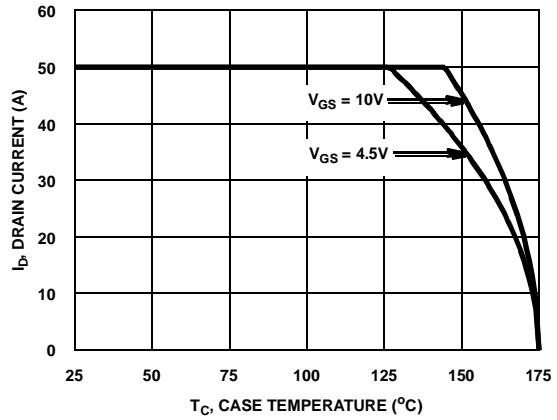

Figure 2. Maximum Continuous Drain Current vs Case Temperature

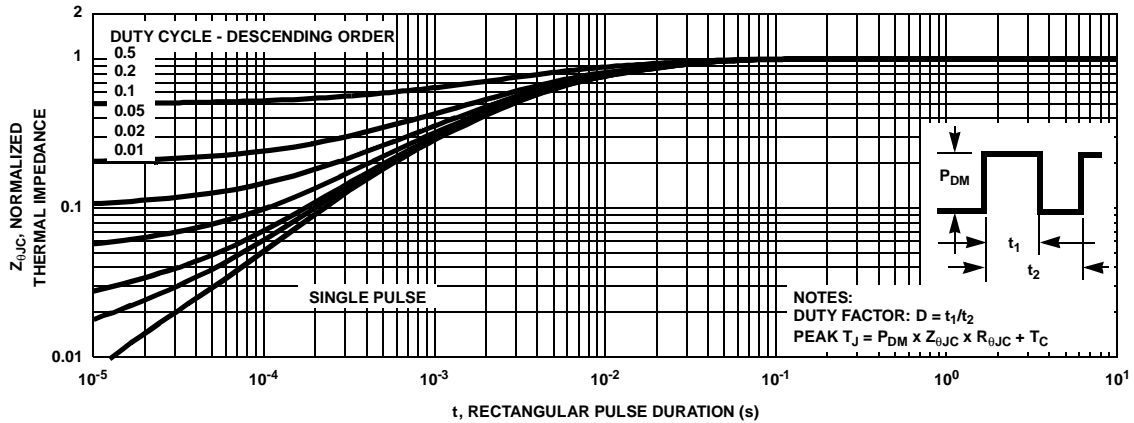

Figure 3. Normalized Maximum transient Thermal Impedance

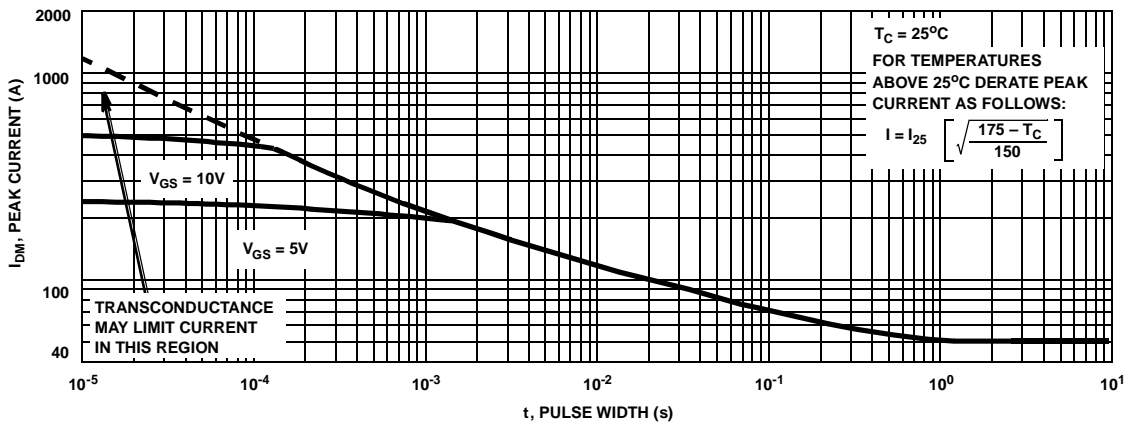

Figure 4. Peak Current Capability

Typical Characteristic

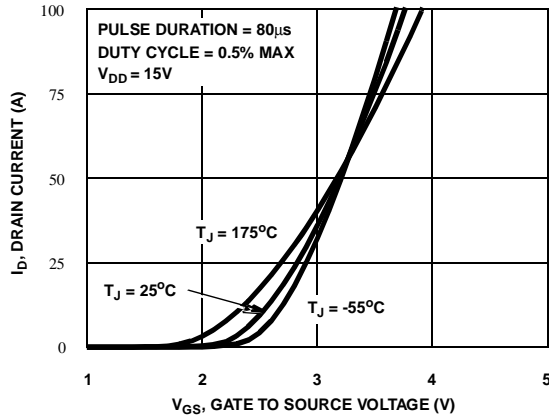

Figure 5. Transfer Characteristics

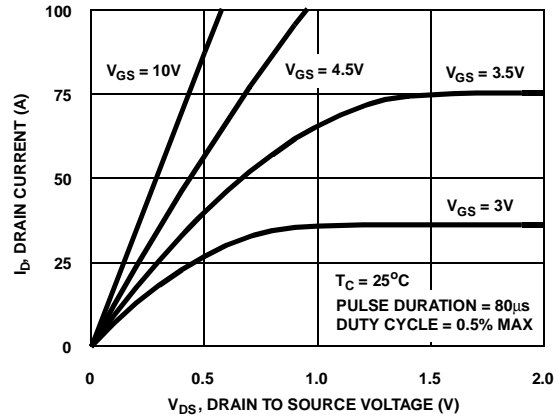

Figure 6. Saturation Characteristics

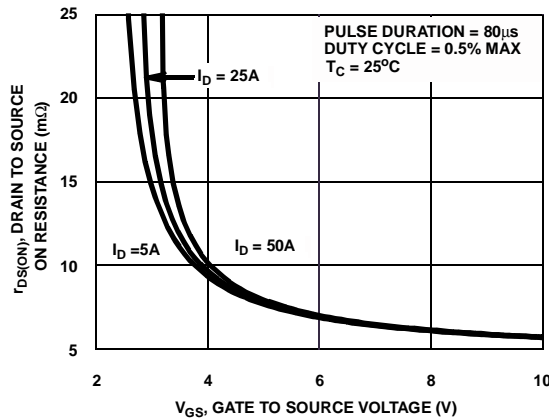

Figure 7. Drain to Source On Resistance vs Gate Voltage and Drain Current

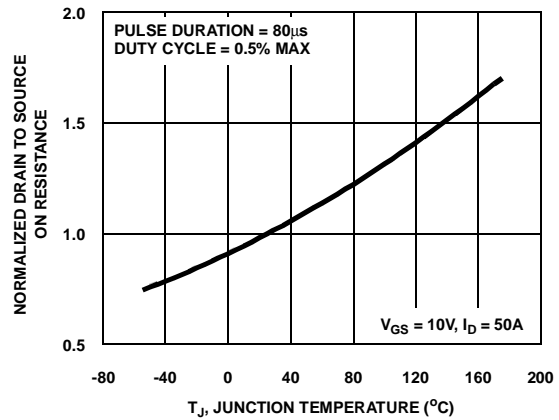

Figure 8. Normalized Drain to Source On Resistance vs Junction Temperature

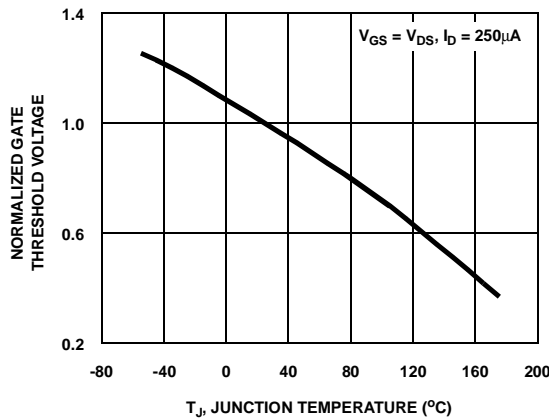

Figure 9. Normalized Gate Threshold Voltage vs Junction Temperature

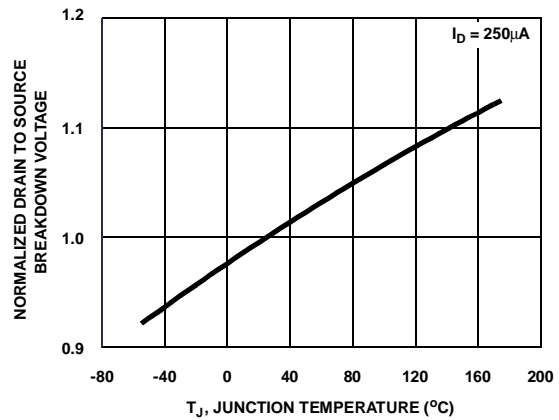

Figure 10. Normalized Drain to Source Breakdown Voltage vs Junction Temperature

Typical Characteristic (Continued)

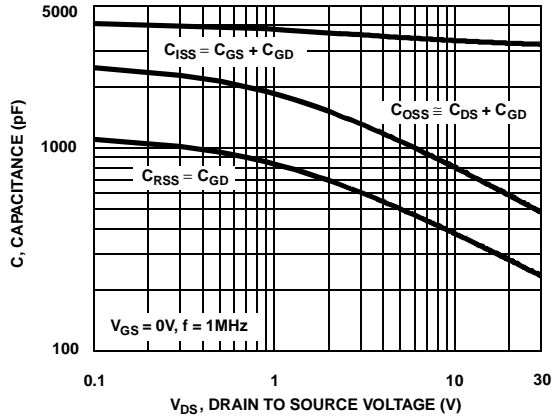

Figure 11. Capacitance vs Drain to Source Voltage

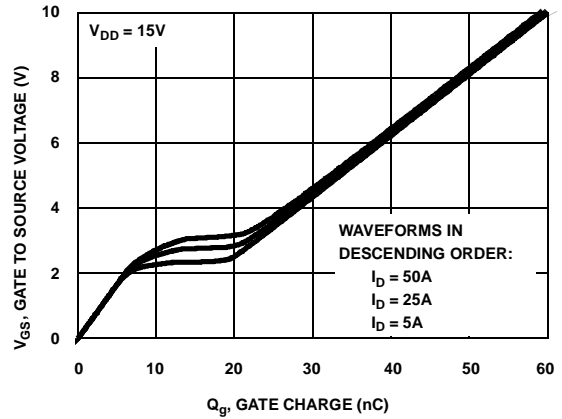

Figure 12. Gate Charge Waveforms for Constant Gate Currents

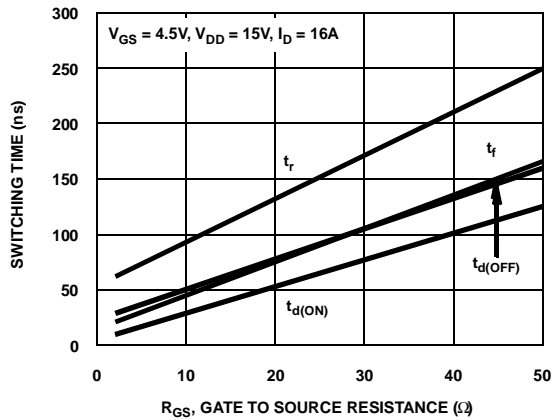

Figure 13. Switching Time vs Gate Resistance

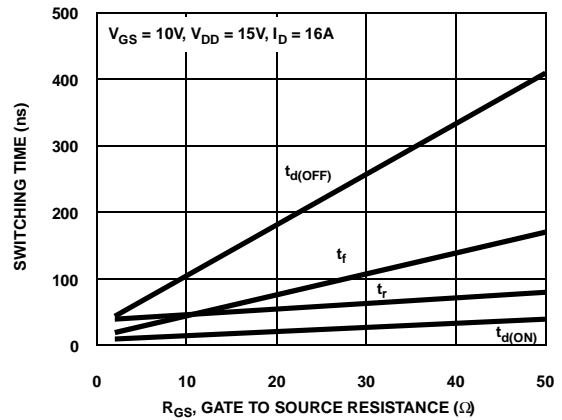
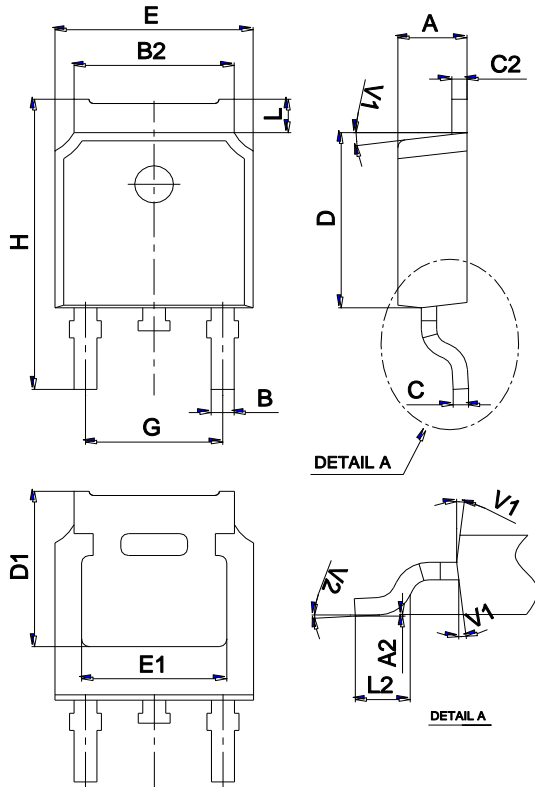
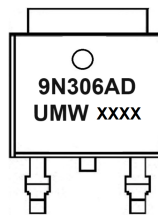

Figure 14. Switching Time vs Gate Resistance

Package Mechanical Data TO-252



Ref.	Dimensions					
	Millimeters			Inches		
	Min.	Typ.	Max.	Min.	Typ.	Max.
A	2.10		2.50	0.083		0.098
A2	0		0.10	0		0.004
B	0.66		0.86	0.026		0.034
B2	5.18		5.48	0.202		0.216
C	0.40		0.60	0.016		0.024
C2	0.44		0.58	0.017		0.023
D	5.90		6.30	0.232		0.248
D1	5.30REF			0.209REF		
E	6.40		6.80	0.252		0.268
E1	4.63			0.182		
G	4.47		4.67	0.176		0.184
H	9.50		10.70	0.374		0.421
L	1.09		1.21	0.043		0.048
L2	1.35		1.65	0.053		0.065
V1		7°			7°	
V2	0°		6°	0°		6°



Ordering information

Order code	Package	Baseqty	Deliverymode
UMW ISL9N306AD3ST	TO-252	2500	Tape and reel

X-ON Electronics

Largest Supplier of Electrical and Electronic Components

Click to view similar products for [MOSFET](#) category:

Click to view products by [Youtai](#) manufacturer:

Other Similar products are found below :

[IRFD120](#) [JANTX2N5237](#) [2SK2267\(Q\)](#) [BUK455-60A/B](#) [TK100A10N1,S4X\(S](#) [MIC4420CM-TR](#) [VN1206L](#) [NDP4060](#) [SI4482DY](#)
[IRS2092STRPBF-EL](#) [IPS70R2K0CEAKMA1](#) [TK31J60W5,S1VQ\(O](#) [TK31J60W,S1VQ\(O](#) [TK16J60W,S1VQ\(O](#) [2SK2614\(TE16L1,Q\)](#)
[DMN1017UCP3-7](#) [EFC2J004NUZTDG](#) [P85W28HP2F-7071](#) [DMN1053UCP4-7](#) [NTE2384](#) [DMC2700UDMQ-7](#) [DMN2080UCB4-7](#)
[DMN61D9UWQ-13](#) [US6M2GTR](#) [DMN31D5UDJ-7](#) [DMP22D4UFO-7B](#) [IPS60R3K4CEAKMA1](#) [DMN1006UCA6-7](#) [DMN16M9UCA6-7](#)
[STF5N65M6](#) [IRF40H233XTMA1](#) [STU5N65M6](#) [DMN6022SSD-13](#) [DMN13M9UCA6-7](#) [DMTH10H4M6SPS-13](#) [IPS60R360PFD7SAKMA1](#)
[DMN2990UFB-7B](#) [SSM3K35CT,L3F](#) [IPLK60R1K0PFD7ATMA1](#) [2N7002W-G](#) [MCAC30N06Y-TP](#) [IPWS65R035CFD7AXKSA1](#)
[MCQ7328-TP](#) [SSM3J143TU,LXHF](#) [DMN12M3UCA6-7](#) [PJMF280N65E1_T0_00201](#) [PJMF380N65E1_T0_00201](#)
[PJMF280N60E1_T0_00201](#) [PJMF600N65E1_T0_00201](#) [PJMF900N65E1_T0_00201](#)