

**Product Introduction**

LM2675 series is a DC/DC switching buck converter controlled by a fixed frequency of 260kHz PWM. It is mainly composed of internal frequency compensation, fixed frequency oscillator, built-in overcurrent protection, power switch control and other circuits. It can drive 1A load with high efficiency, low ripple, good linearity and load adjustment ability. Only a few external components are needed to realize the function of DC/DC voltage reduction and stabilization, which is very simple and practical. PWM control circuit can adjust the duty cycle from 0 according to the load To 100% to achieve high work efficiency. It has an external enabling control opening function, which can realize the controllable switch between standby and work, making the application more flexible.

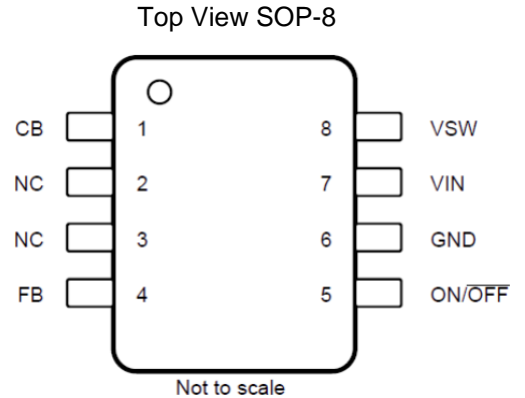

**Product features**

- Built in overtemperature shutdown function
- Built in overcurrent protection function
- Internal integrated efficient power switch
- Good linearity and load adjustment capability
- ON/OFF pin with hysteresis function
- TTL shutdown capability
- high efficiency
- Simple periphery
- Wide input voltage range: 7V~40V
- Fixed output voltage: 3.3V, 5V, 12V
- Adjustable output voltage range: 1.21V~37V (adjustable)
- High precision output: ± 2%
- Fixed switching frequency: 260 kHz
- Maximum output current capacity: 1A
- Minimum linear drop voltage drop: 1.5V
- Package form: SOP-8

**Packaging form and pin function definition**

Pin serial number	Pin definition	Function description
SOP-8		
1	CB	Boost capacitance terminal
2	NC	Empty port
3	NC	Empty port
4	FB	Feedback control terminal
5	ON/OFF	Enable terminal High=ON and low=OFF
6	GND	Power supply ground terminal
7	VIN	Positive terminal of power supply
8	VSW	Power switch output terminal (SW)

**Product use**

- LCD and LCD TV
- ADSL modem
- LED lights, LED backlight
- Digital photo frame
- Telecommunication/network equipment

■ Application circuit

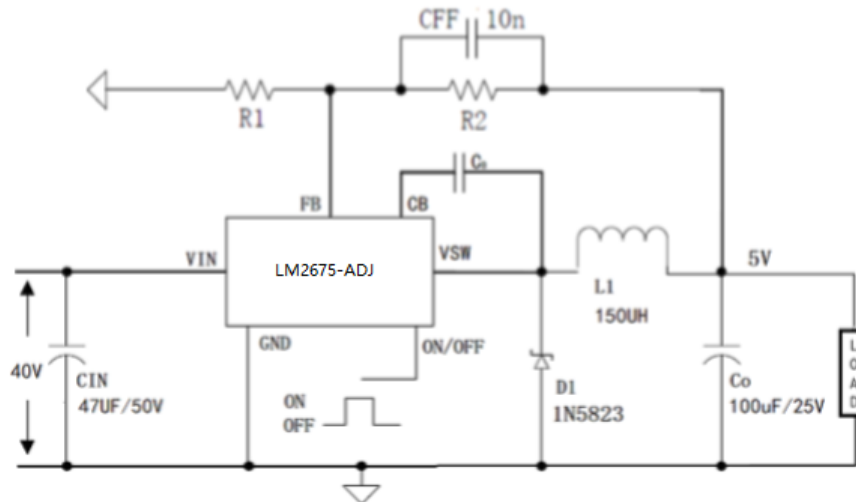
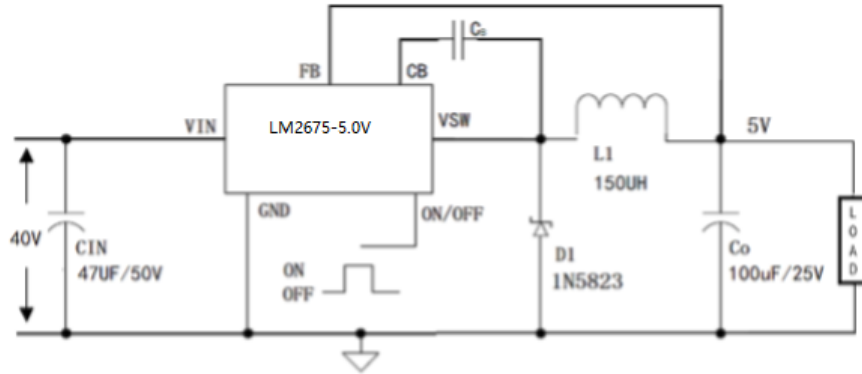

$$V_{OUT} = V_{REF} (1 + R2/R1)$$

C<sub>B</sub> : 103/50V

**Limit parameter**

project	Symbol	explain	Limit value	Company
Voltage	V <sub>IN</sub>	Input terminal voltage	-0.3~42	V
	V <sub>FB</sub>	FB feedback terminal voltage	-0.3~V <sub>IN</sub>	V
	V <sub>VSW</sub>	Switch output terminal voltage	-1~V <sub>IN</sub>	V
	V <sub>ON-OFF</sub>	Enable enabling terminal voltage	-0.3~6	V
Maximum power consumption	PD	SOP8 package	500	mW
thermal resistance	R <sub>JA</sub>	Put in air without external heat sink	30	°C/W
temperature	T <sub>J</sub>	Operating temperature range	-40~125	°C
	T <sub>c</sub>	Storage temperature range	-40~150	
	T <sub>h</sub>	welding temperature	260	°C,10s

Note: Limit parameter refers to the limit value that cannot be exceeded under any conditions. Once the limit value is exceeded, it may cause physical damage such as product deterioration. At the same time, the chip can not be guaranteed to work normally under the limit parameters.

**electrical properties**
**LM2675-3.3V (Ta=25°C)**

project	Symbol	Test conditions	minimum value	Typical value	Maximum	Company
output voltage	V <sub>OUT</sub>	V <sub>IN</sub> =7V to 40V, I <sub>OUT</sub> =20mA to 1A	3.234	3.3	3.366	V
Enable shutdown current	I <sub>STB</sub>	V <sub>IN</sub> =40V, V <sub>ON-OFF</sub> =0V	-	100	200	uA
Quiescent current	I <sub>Q</sub>	V <sub>IN</sub> =12V, V <sub>FB</sub> =8V, V <sub>ON-OFF</sub> =5V,	-	3	7	mA
Output peak current	I <sub>CL</sub>	V <sub>IN</sub> =12V, V <sub>ON-OFF</sub> =5V, V <sub>FB</sub> =0, no L1 and D1	-	2	-	A
Output leakage current	I <sub>OL</sub>	V <sub>IN</sub> =40V, V <sub>ON-OFF</sub> =0V, no L1 and D1	V <sub>VSW</sub> =0V	-	10	uA
			V <sub>VSW</sub> =-1V	-	2.5	10
Enable enable terminal current	I <sub>ON-OFL</sub>	V <sub>IN</sub> =12V, V <sub>ON-OFF</sub> =0.5V	-	4	15	uA
	I <sub>ON-OFFH</sub>	V <sub>IN</sub> =12V, V <sub>ON-OFF</sub> =2.5V	-	1.5	15	uA
Enable effective voltage of enable terminal	V <sub>ON-OFFH</sub>	V <sub>IN</sub> =12V (ON)	1.5	-	-	V
	V <sub>ON-OFL</sub>	V <sub>IN</sub> =12V (OFF)	-	-	0.8	V
Output saturation voltage	V <sub>CE</sub>	V <sub>IN</sub> =12V, V <sub>FB</sub> =0V, I <sub>OUT</sub> = 1A	-	1.0	1.5	V
switching frequency	f <sub>osc</sub>	V <sub>IN</sub> =12V	225	260	275	kHz
Duty cycle	D <sub>max</sub>	V <sub>IN</sub> =12V, V <sub>FB</sub> =0V,	0	-	100	%
efficiency	η	V <sub>IN</sub> =12V, V <sub>OUT</sub> =3.3V, I <sub>OUT</sub> =1A	-	80	-	%
input voltage	V <sub>IN</sub>	-	7	-	40	V

◆ LM2675-5.0V (Ta=25°C)

project	Symbol	Test conditions	minimum value	Typical value	Maximum	Company
output voltage	$V_{OUT}$	$V_{IN} = 7 \text{ to } 40V, I_{OUT} = 20mA \text{ to } 1A$	4.90	5	5.10	V
Enable shutdown current	$I_{STB}$	$V_{IN} = 40V, V_{ON-OFF} = 0V$	-	100	200	uA
Quiescent current	$I_Q$	$V_{IN} = 12V, V_{FB} = 8V, V_{ON-OFF} = 5V,$	-	3	7	mA
Output peak current	$I_{CL}$	$V_{IN} = 12V, V_{ON-OFF} = 5V, V_{FB} = 0,$ no L1 and D1	-	2	-	A
Output leakage current	$I_{OL}$	$V_{IN} = 40V, V_{ON-OFF} = 0V,$ no L1 and D1	-		10	uA
		$V_{VSW} = 0V$	-	2.5	10	mA
Enable enable terminal current	$I_{ON-OFFL}$	$V_{IN} = 12V, V_{ON-OFF} = 0.5V$	-	4	15	uA
	$I_{ON-OFFH}$	$V_{IN} = 12V, V_{ON-OFF} = 2.5V$	-	1.5	15	uA
Enable effective voltage of enable terminal	$V_{ON-OFFH}$	$V_{IN} = 12V (ON)$	1.5	-	-	V
	$V_{ON-OFFL}$	$V_{IN} = 12V (OFF)$	-	-	0.8	V
Output saturation voltage	$V_{CE}$	$V_{IN} = 12V, V_{FB} = 0V, I_{OUT} = 1A$	-	1.0	1.5	V
switching frequency	$f_{osc}$	$V_{IN} = 12V$	225	260	275	kHz
Duty cycle	$D_{max}$	$V_{IN} = 12V, V_{FB} = 0V,$	0	-	100	%
efficiency	$\eta$	$V_{IN} = 12V, V_{OUT} = 5V, I_{OUT} = 1A$	-	80	-	%
input voltage	$V_{IN}$	-	7	-	40	V

◆ LM2675-12V (Ta=25°C)

project	Symbol	Test conditions	minimum value	Typical value	Maximum	Company
output voltage	$V_{OUT}$	$V_{IN} = 14$ to $40V$ , $I_{OUT} = 20mA$ to $1A$	11.76	12	12.24	V
Enable shutdown current	$I_{STB}$	$V_{IN} = 40V$ , $V_{ON-OFF} = 0V$	-	100	200	uA
Quiescent current	$I_q$	$V_{IN} = 15V$ , $V_{FB} = 13V$ , $V_{ON-OFF} = 5V$ ,	-	3	7	mA
Output peak current	$I_{CL}$	$V_{IN} = 15V$ , $V_{ON-OFF} = 5V$ , $V_{FB} = 0$ , no L1 and D1	-	2	-	A
Output leakage current	$I_{OL}$	$V_{IN} = 40V$ , $V_{ON-OFF} = 0V$ , no L1 and D1	$V_{VSW} = 0V$	-	10	uA
			$V_{VSW} = -1V$	-	2.5	10
Enable enable terminal current	$I_{ON-OFFL}$	$V_{IN} = 15V$ , $V_{ON-OFF} = 0.5V$	-	4	15	uA
	$I_{ON-OFFH}$	$V_{IN} = 15V$ , $V_{ON-OFF} = 2.5V$	-	1.5	15	uA
Enable effective voltage of enable terminal	$V_{ON-OFFH}$	$V_{IN} = 15V$ (ON)	1.5	-	-	V
	$V_{ON-OFFL}$	$V_{IN} = 15V$ (OFF)	-	-	0.8	V
Output saturation voltage	$V_{CE}$	$V_{IN} = 15V$ , $V_{FB} = 0V$ , $I_{OUT} = 1A$	-	1.0	1.5	V
switching frequency	$f_{osc}$	$V_{IN} = 15V$	225	260	275	kHz
Duty cycle	$D_{max}$	$V_{IN} = 15V$ , $V_{FB} = 0V$ ,	0	-	100	%
efficiency	$\eta$	$V_{IN} = 15V$ , $V_{OUT} = 12V$ , $I_{OUT} = 1A$	-	85	-	%
input voltage	$V_{IN}$	-	13.5	-	40	V

◆ LM2675-ADJ (Ta=25°C)

project	Symbol	Test conditions	minimum value	Typical value	Maximum	Company
Reference voltage	$V_{REF}$	$V_{IN} = 7V$ to $40V$ , $I_{OUT} = 20mA$ to $1A$	1.185	1.21	1.234	V
Enable shutdown current	$I_{STB}$	$V_{IN} = 40V$ , $V_{ON-OFF} = V_{VSW}$	-	100	200	uA
Quiescent current	$I_q$	$V_{ON-OFF} = 0V$ , $V_{FB} = V_{IN}$	-	3	7	mA
Output peak current	$I_{CL}$	$V_{ON-OFF} = V_{FB} = 0$ , no L1 and D1	-	2	-	A
Output leakage current	$I_{OL}$	$V_{IN} = V_{FB}$ , $V_{ON-OFF} = 5V$ , no L1 and D1	$V_{VSW} = 0V$	-	10	uA
			$V_{VSW} = -1V$	-	2.5	10
Enable enable terminal current	$I_{ON-OFL}$	$V_{IN} = 12V$ , $V_{ON-OFF} = 0.5V$	-	4	15	uA
	$I_{ON-OFFH}$	$V_{IN} = 12V$ , $V_{ON-OFF} = 2.5V$	-	1.5	15	uA
Enable effective voltage of enable terminal	$V_{ON-OFFH}$	$V_{IN} = 12V$ (OFF)	1.5	-	-	V
	$V_{ON-OFL}$	$V_{IN} = 12V$ (ON)	-	-	0.8	V
Feedback terminal current	$I_{FB}$	$V_{IN} = 12V$ , $I_{FB} = 1.3V$	-	85	-	nA
Output saturation voltage	$V_{CE}$	$V_{IN} = 12V$ , $V_{FB} = 0V$ , $I_{OUT} = 1A$	-	1.0	1.5	V
switching frequency	$f_{osc}$	$V_{IN} = 12V$	225	260	275	kHz
Duty cycle	$D_{max}$	$V_{IN} = 12V$ , $V_{FB} = 0V$ ,	0	-	100	%
efficiency	$\eta$	$V_{IN} = 12V$ , $V_{OUT} = 5V$ , $I_{OUT} = 1A$	-	80	-	%
input voltage	$V_{IN}$	-	7	-	40	V

■ Encapsulation information

SOP-8

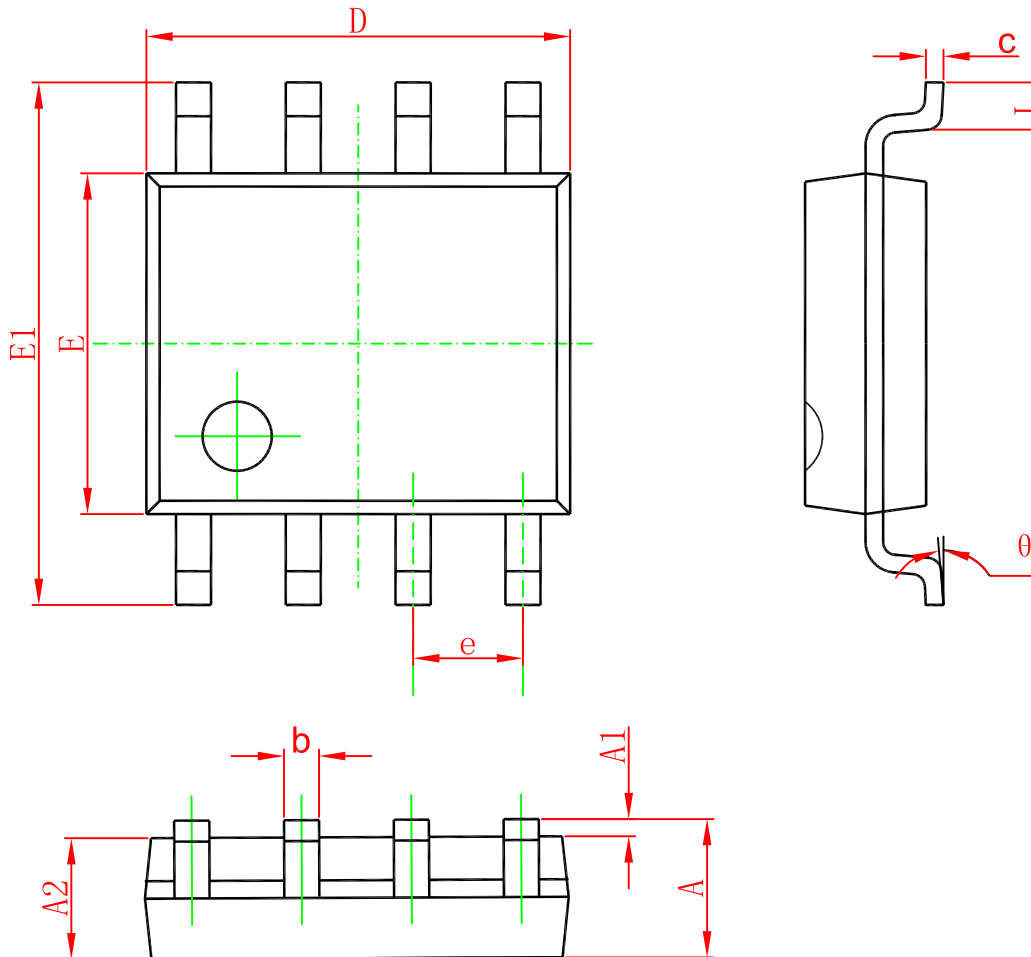

Symbol	Dimensions In Millimeters		Dimensions In Inches	
	Min	Max	Min	Max
A	1.350	1.750	0.053	0.069
A1	0.100	0.250	0.004	0.010
A2	1.350	1.550	0.053	0.061
b	0.330	0.510	0.013	0.020
c	0.170	0.250	0.006	0.010
D	4.700	5.100	0.185	0.200
E	3.800	4.000	0.150	0.157
E1	5.800	6.200	0.228	0.244
e	1.270(BSC)		0.050(BSC)	
L	0.400	1.270	0.016	0.050
theta	0°	8°	0°	8°

**Ordering information**

Order code	Package	Baseqty	Deliverymode
UMW LM2675M-3.3	SOP-8	2500	Tape and reel
UMW LM2675M-5.0	SOP-8	2500	Tape and reel
UMW LM2675M-12	SOP-8	2500	Tape and reel
UMW LM2675M-ADJ	SOP-8	2500	Tape and reel



## X-ON Electronics

Largest Supplier of Electrical and Electronic Components

*Click to view similar products for [Switching Voltage Regulators](#) category:*

*Click to view products by [Youtai](#) manufacturer:*

Other Similar products are found below :

[FAN53610AUC33X](#) [FAN53611AUC123X](#) [MP2374DS-LF-Z](#) [EN6310QA](#) [NCP81108MNTXG](#) [NCP81109BMNTXG](#) [R3](#) [LV5710GP-TE-L-H](#) [KE177614](#) [MPQ4423GQ-AEC1-Z](#) [FAN53611AUC12X](#) [MAX809TTR](#) [NCV891234MW50R2G](#) [NCP6332CMTAATBG](#) [AST1S31PUR](#) [NCP81103MNTXG](#) [NCP81203PMNTXG](#) [NCP81208MNTXG](#) [PCA9412AUKZ](#) [NCP81109GMNTXG](#) [SCY1751FCCT1G](#) [NCP81109JMNTXG](#) [MP2161AGJ-Z](#) [NCP81241MNTXG](#) [MP2388GQEU-Z](#) [MPQ4481GU-AEC1-P](#) [MP8756GD-P](#) [MPQ2171GJ-P](#) [MPQ2171GJ-AEC1-P](#) [MP2171GJ-P](#) [NCV1077CSTBT3G](#) [MP28160GC-Z](#) [MPM3509GQVE-AEC1-P](#) [XDPE132G5CG000XUMA1](#) [MP5461GC-P](#) [IR3888AMTRPBFAUMA1](#) [MPQ4409GQBE-AEC1-P](#) [S-19903DA-A8T1U7](#) [S-19903CA-A6T8U7](#) [S-19903CA-S8T1U7](#) [S-19902BA-A6T8U7](#) [S-19902CA-A6T8U7](#) [AP7361EA-SPR-13](#) [AP7361EA-33DR-13](#) [S-19902AA-A6T8U7](#) [S-19903AA-A6T8U7](#) [S-19902AA-S8T1U7](#) [S-19902BA-A8T1U7](#) [AU8310](#) [LMR36503R5RPER](#)