

Summary

LM311DR and LM211DR can work on a single power supply of 5V to 30V or a dual power supply of $\pm 15V$. Like the commonly used comparator, LM311 can become a real universal comparator. The input of LM311DR and LM211DR can be isolated from the system, and the output can be referenced to ground, power supply or VEE. This flexibility can drive DTL, RTL, TTL or MOS level logic. When the output current is 50MA, the output can switch the voltage to 50V, which can be used to drive relays, lamps or solenoids.

Pin arrangement diagram

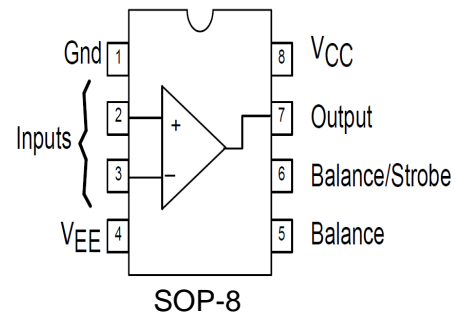

Typical comparator design scheme

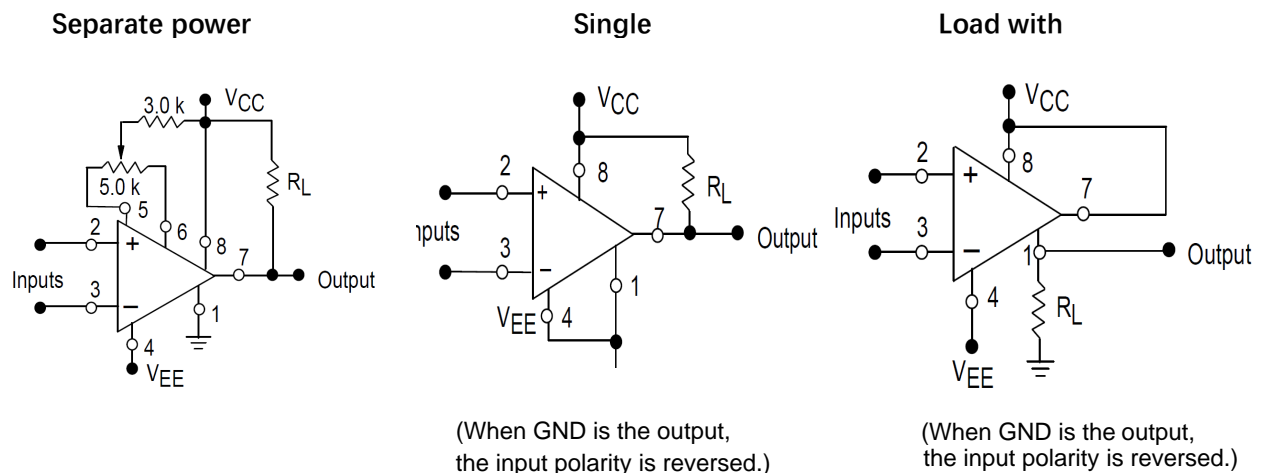

Load referenced to negative power supply positive power supply

High flexibility voltage comparator
Gating ability

Load with reference to

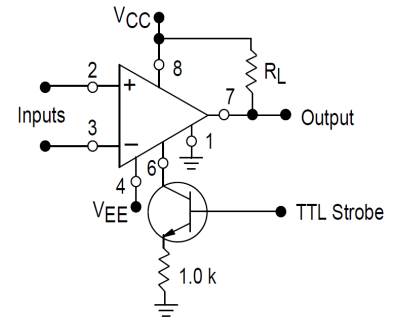
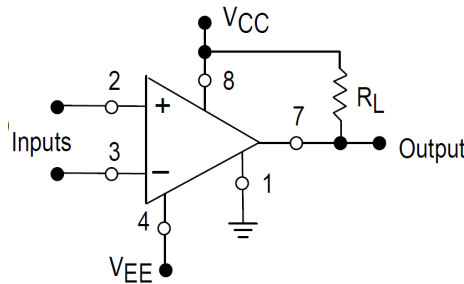
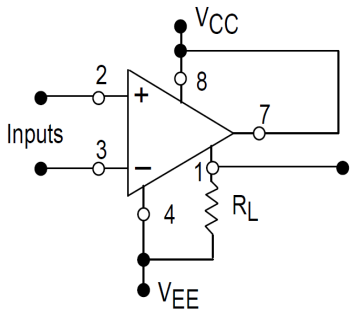

Limit parameter (ta = +25C°, untitled otherwise.)

Rating	Symbol	LM211	LM311	Unit
Total supply voltage	$V_{CC} + V_{EE} $	36	36	Vdc
Output to negative supply voltage	$V_O - V_{EE}$	50	40	Vdc
Ground to negative power supply	V_{EE}	30	30	Vdc
Input differential voltage	V_{ID}	30	30	Vdc
Input voltage (Note 2)	V_{in}	15	15	Vdc
Strobe pin voltage gating	-	V_{CC} to $V_{CC}-5$	V_{CC} to $V_{CC}-5$	Vdc
Power consumption and thermal characteristics plastic package DIP Ta decreases when it exceeds 25C°	PD	625 5.0		mW mW/°C
operating ambient temperature	TA	-25 to +85	0 to +70	°C
operating junction temperature range	TJ(max)	+150	+150	°C
storage temperature	Tstg	-65 to +150	-65 to +150	°C

Electrical characteristics (VCC = +15 V, VEE = -15 V, TA = 25C°, UNLESS Otherwise Noted [Note 1].)

parameter	Symbol	LM211			LM311			Unit
		Min	Typ	Max	Min	Typ	Max	
Input offset voltage (Note 3) RS ≤ 50 k , TA = +25°C RS ≤ 50 k , Tlow ≤ TA ≤ Thigh*	VIO	-	0.7	3.0	-	2.0	7.5	mV
Offset current (Note 3) TA = +25°C Tlow ≤ TA ≤ Thigh*	IIO	-	1.7	10	-	1.7	50	nA
Input bias current TA = +25°C Tlow ≤ TA ≤ Thigh*	IIB	-	45	100	-	45	250	nA
		-	-	150	-	-	300	
Voltage gain	AV	40	200	-	40	200	-	V/mV

High flexibility voltage comparator

parameter	Symbol	LM211			LM311			Unit
		Min	Typ	Max	Min	Typ	Max	
Response time (Note 4)		-	200	-	-	200	-	ns
Output saturation pressure drop VID ≤ -5.0 mV, IO = 50 mA, TA = 25°C VID ≤ -10 mV, IO = 50 mA, TA = 25°C VCC ≥ 4.5 V, VEE = 0, Tlow ≤ TA ≤ Thigh* VID ≤ 6.0 mV Isink ≤ 8.0 mA VID ≤ 10 mV Isink ≤ 8.0 mA	VOL	-	0.75	1.5	-	-	-	V
Gated on current (Note 5)	IS	-	3.0	-	-	3.0	-	mA
Output leakage current VID ≤ 5.0 mV, VO = 35 V, TA = 25°C, Istrobe = 3.0 mA VID ≤ 10 mV, VO = 35 V, TA = 25°C, Istrobe = 3.0 mA VID ≤ 5.0 mV, VO = 35 V, Tlow ≤ TA ≤ Thigh*		-	0.2	10	-	-	-	nA nA uA
Input voltage (tlow ≤ ta ≤ thigh *)	VICR	-14.5	-14.7 to 13.8	+13.0	-14.5	-14.7 to 13.8	+13.0	V
Positive supply current	ICC	-	+2.4	+6.0	-	+2.4	+7.5	mA
Negative supply current	IEE	-	-1.3	-5.0	-	-1.3	-5.0	mA

* Tlow = 25°C corresponds to LM211, and tlow = 0°C corresponds to LM311.

* Thigh = 85°C corresponds to LM211, and Thigh = 75°C corresponds to LM311.

NOTES: 1. The specifications of offset voltage, offset current and bias current correspond to the power supply voltage of 5V to ±15V.

2. This rating is for the case of ±15V power supply. The positive input voltage limit is 30V higher than the negative power supply, and the negative input limit is equivalent to the negative power supply voltage, or 30V lower than the power supply, or whichever is smaller.

3. Given offset voltage and offset current, it is required to drive a load with a maximum value of 1mA in any power supply voltage range, and these parameters define the error range, thus taking the worst case of voltage gain and input impedance into account.

4. The specified response time is 100mV input plus 5mV overdrive signal.

5. Don't directly ground the STROBE pin, it needs to be driven by 3mA~5mA current.

High flexibility voltage comparator

schematic circuit diagram

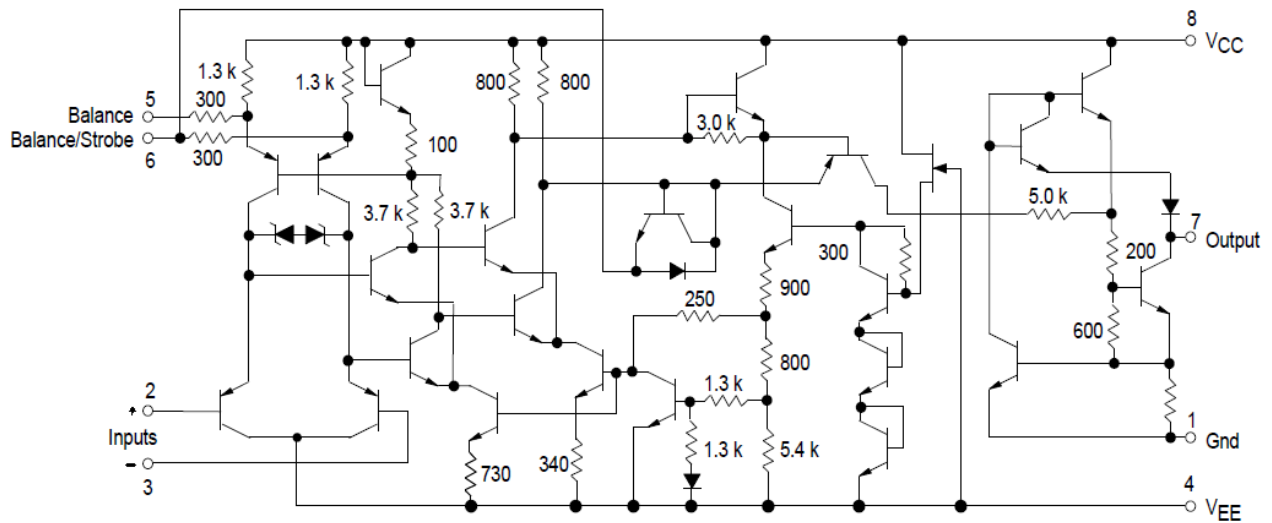

Relationship between input bias current and temperature

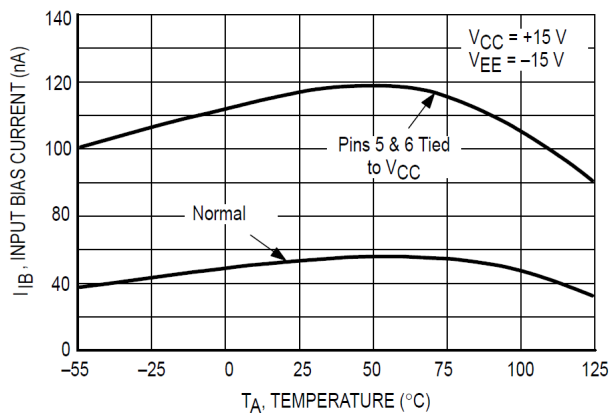

Relationship between input offset current and temperature

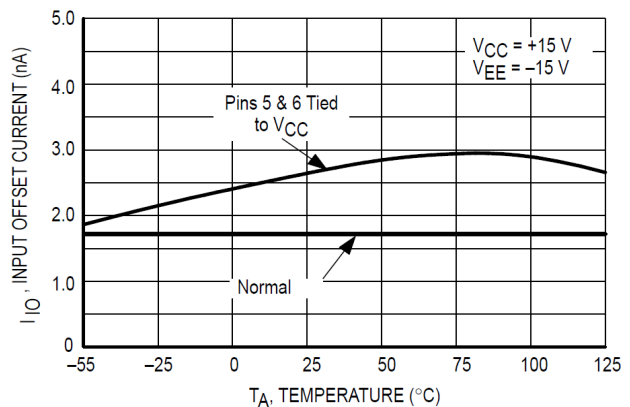

Relationship between input bias current and input

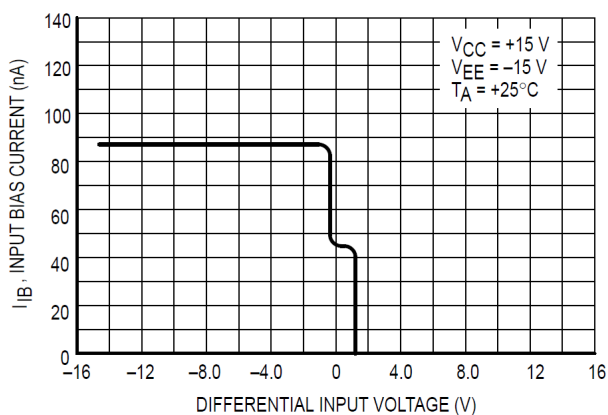

Relationship between common mode

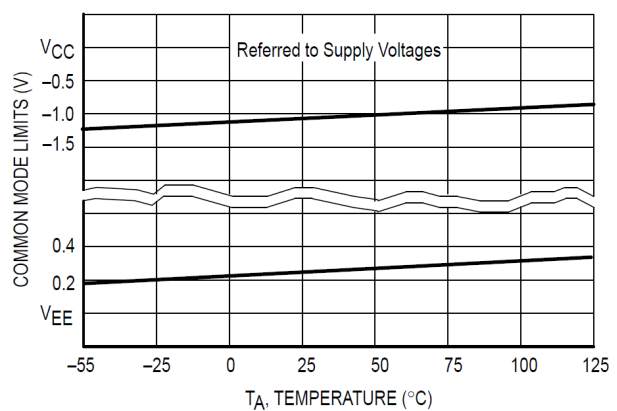

High flexibility voltage comparator

Relationship between output leakage current and temperature

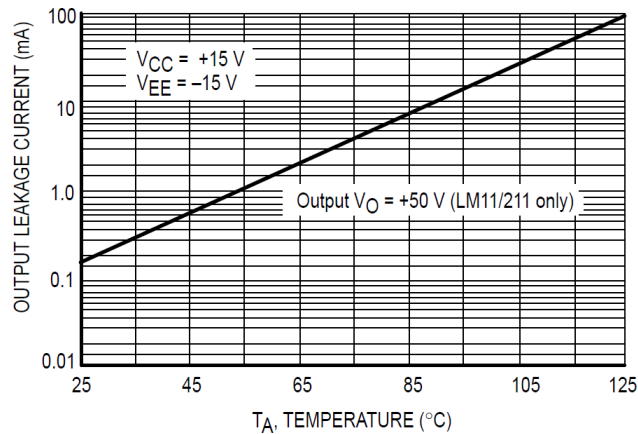

An improved method without input positive feedback and lag hysteresis

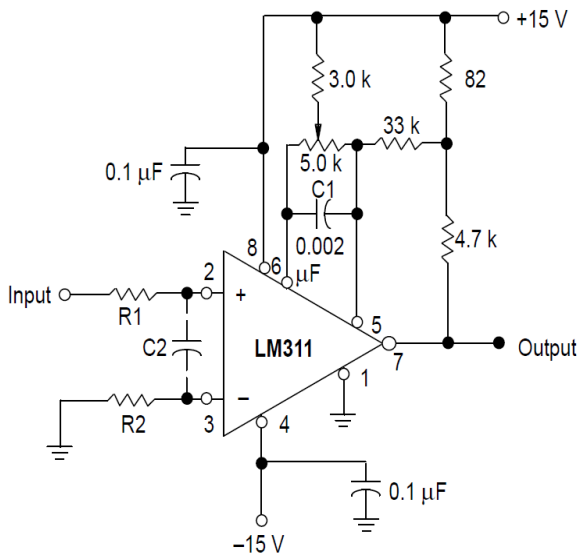

Techniques for adding

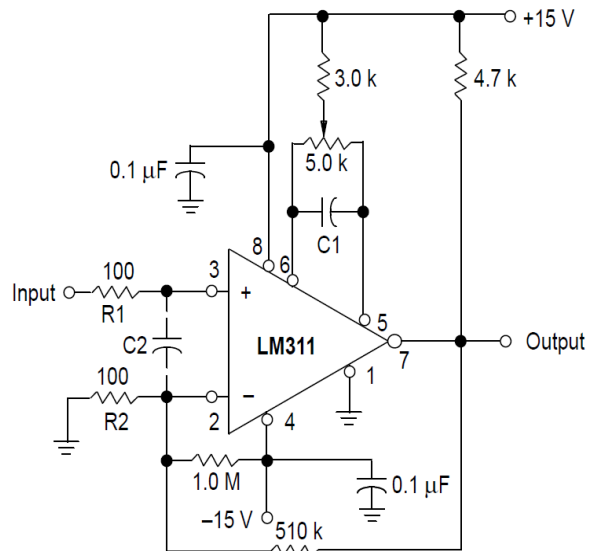

Zero-crossing detector driving CMOS logic

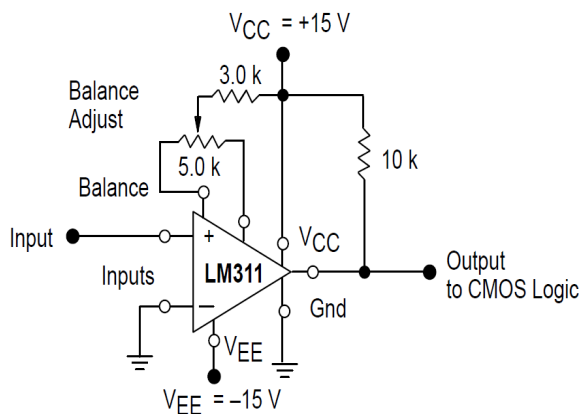

Relay driver with gating capability

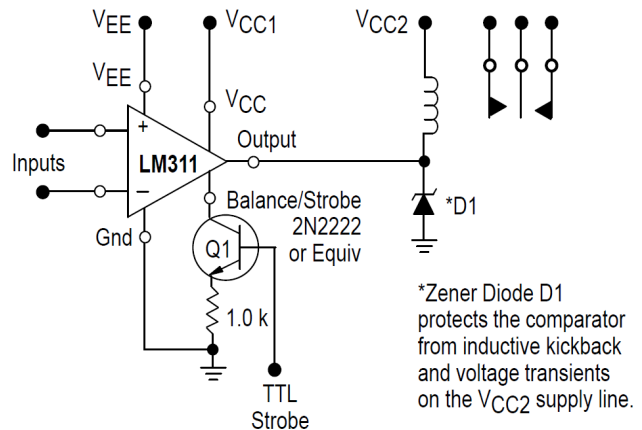

PACKAGE OUTLINE DIMENSIONS

SOP-8

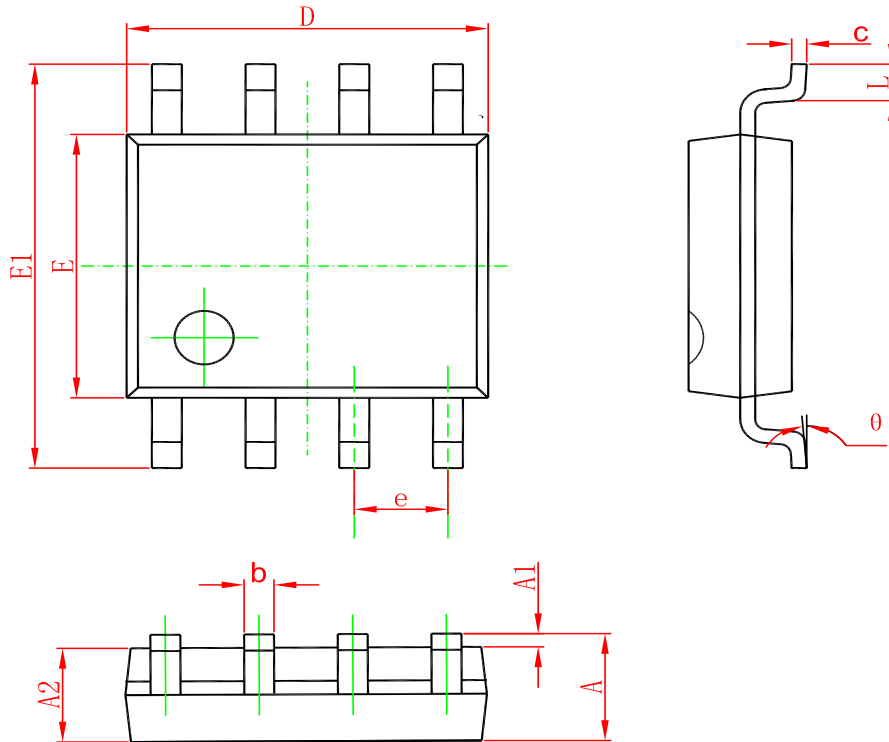

Symbol	Dimensions In Millimeters		Dimensions In Inches	
	Min	Max	Min	Max
A	1.350	1.750	0.053	0.069
A1	0.100	0.250	0.004	0.010
A2	1.350	1.550	0.053	0.061
b	0.330	0.510	0.013	0.020
c	0.170	0.250	0.006	0.010
D	4.700	5.100	0.185	0.200
E	3.800	4.000	0.150	0.157
E1	5.800	6.200	0.228	0.244
e	1.270(BSC)		0.050(BSC)	
L	0.400	1.270	0.016	0.050
theta	0°	8°	0°	8°

Marking

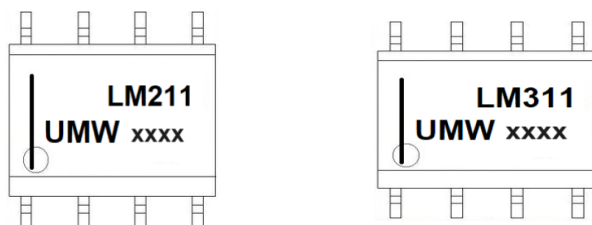

Ordering information

Order code	Package	Baseqty	Deliverymode
UMW LM311DR	SOP-8	2500	Tape and reel
UMW LM211DR	SOP-8	2500	Tape and reel

X-ON Electronics

Largest Supplier of Electrical and Electronic Components

Click to view similar products for [Analog Comparators](#) category:

Click to view products by [Youtai](#) manufacturer:

Other Similar products are found below :

[SC2903VDR2G](#) [LM2901SNG](#) [LM339SNG](#) [5962-8757203IA](#) [NTE911](#) [LM339EDR2G](#) [NTE922](#) [UPC311G2-E1-A](#) [UPC311G2-E2-A](#)
[UPC272G2-E1-A](#) [UPC277G2-E2-A](#) [UPC177G2-E2-A](#) [UPC271G2-E2-A](#) [TLV1811DBVR](#) [HT393VRMZ](#) [LM2903YD](#) [NCV2200SN1T1G](#)
[LM2903A-SR](#) [LM2903A-VR](#) [HT393ARZ](#) [LM2903](#) [LM2904](#) [LM393D](#) [LM393](#) [LMV331SN3T1G](#) [LMV331ILT](#) [LMV331W5](#)
[LMV331IDBVR](#) [LMV331M5X](#) [TPV331S5](#) [LM339A-SR](#) [GS8748-SR](#) [LM311MM/TR](#) [LM211MM/TR](#) [HT339ARQZ](#) [LM393DR-HXY](#)
[LM2903XK-Q1](#) [RS393XK-Q1](#) [LM2903XM](#) [RS339XQ](#) [LM331CXF](#) [RS393XM](#) [LM2901XP](#) [LM2901DR-JSM](#) [LM239DR-JSM](#) [LM339](#)
[LR2903D](#) [TS391IL](#) [LM331A-S5TR](#) [GSV331R-TR](#)