

### Description

LMV321 (single channel) is a rail-to-rail input, output voltage feedback, low power consumption operational amplifier. It has wide input common mode voltage and output swing. The minimum working voltage can be up to 2.1V, and the maximum working voltage is recommended to be 5.5V. Used as power amplifier in all kinds of pocket or portable stereo radio recorders.

LMV321 has the following characteristics: Can provide 1MHz gain bandwidth product. It has an extremely low input bias current (about 10pA TYP) and can be used for integration, photo diode amplifiers and piezoelectric sensors. The Rail to Rail input and output buffers are also used for specific IC designs in single power systems. Applications of this series of amplifiers include safety monitoring, portable devices, batteries and power supplies, supply control, signal processing and interfaces in low power sensor systems.

The LMV321 single is available in Green SC70-5 and SOT23-5 packages. The LMV358 dual is available in Green SOP-8 and TSSOP-8 packages. The LMV324 Quad is available in Green SOP-14 and TSSOP-14 packages.

### Features

- Rail to rail input and output, typical 0.8mv Vos
- Gain bandwidth product 1MHz
- Low input bias current: 10pA (TYP)
- Low Power consumption
- 2.1V ~ 5.5V working voltage
- Low operating current: 45uA

### Application

- ASIC input and output amplifier
- Sensor interface
- Piezoelectric sensing amplifier
- Battery-powered equipment
- The mobile communication
- Audio output

### Pin Configuration

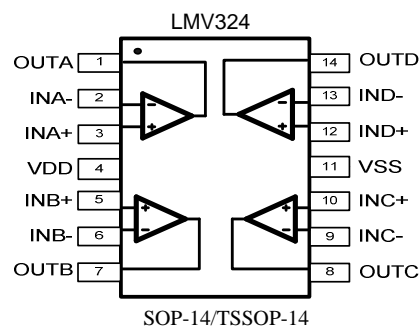
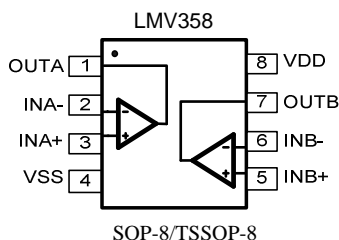
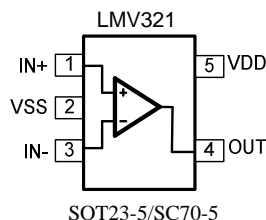

## Low-Power rail-to-rail Operational Amplifier

### Absolute Maximum Ratings (T<sub>A</sub>=25°C) <sup>Note1</sup>

Parameter	Symbol	Value	Units
Supply Voltage	V <sub>CC</sub>	7.5	V
Common-mode Input Voltage	V <sub>ICR</sub>	(-V <sub>S</sub> )-0.5~(+V <sub>S</sub> )0.5	V
Junction Temperature	T <sub>J</sub>	150	°C
Operating Temperature Range	T <sub>OPR</sub>	-25 to +85	°C
Lead Temperature (Soldering, 10 sec)	T <sub>L</sub>	250	°C
Storage Temperature Range	T <sub>STG</sub>	-50 to 150	°C

Note1: Exceeding the above limits may damage to the chip. The reliability of the device will also be affected if the device works under the limit conditions. Electrostatic discharge can also cause damage to chips, so it is suggested to take some preventive measures for integrated circuits. Failure to follow proper handling and installation can also cause damage. Precision LMV321 and other devices are more vulnerable to damage than ordinary devices in the case of tiny electrostatic, and small parameter changes may make the whole circuit performance substandard.

### Electrical Characteristics

At R<sub>L</sub> = 100kΩ connected to V<sub>S</sub>/2, and V<sub>OUT</sub> = V<sub>S</sub>/2, T<sub>A</sub>=25°C, unless otherwise noted.

Parameter	Symbol	Conditions	Min.	Typ.	Max.	Units
Input Offset Voltage	V <sub>OS</sub>		--	±0.8	±5	mV
Input offset current	I <sub>OS</sub>		--	10	--	pA
Input bias current	I <sub>B</sub>		--	10	--	pA
Common-mode input voltage range	V <sub>CM</sub>	V <sub>S</sub> =5.5V	--	-0.1~5.6	--	V
Open-loop Gain	AOL	V <sub>O</sub> =0.1V to 4.9 V, R <sub>L</sub> =5 kΩ	70	80	--	dB
		V <sub>O</sub> =0.035V to 4.96 V, R <sub>L</sub> =100 kΩ	80	84	--	
Common Mode Rejection	CMRR	V <sub>CM</sub> = -0.1V~4 V, V <sub>S</sub> =5.5V	62	70	--	dB
		V <sub>CM</sub> = -0.1V~5.6 V, V <sub>S</sub> =5.5V	56	68	--	
Power Supply Rejection	PSRR	V <sub>CM</sub> = (-V <sub>S</sub> )+0.5 V, V <sub>S</sub> =2.5V~5.5V	60	80	--	dB
Input offset voltage drift	ΔV <sub>OS</sub> /ΔT		--	2.7	--	μV/°C
Input voltage swing	V <sub>I</sub>	R <sub>L</sub> = 100 kΩ	--	8	--	mV
		R <sub>L</sub> =10 kΩ	--	80	--	mV
Operating voltage range	V <sub>W</sub>		2.1	--	5.5	mV
Output Current	I <sub>O</sub>		20	25	--	mA
Quiescent Current	I <sub>Q</sub>	IOUT=0	--	45	60	μA
Slew Rate	SR	G = +1, 2V Output Step	--	0.52	--	V/μs
Gain Bandwidth Product	GBP	CL = 100pF	--	1	--	MHz
Equivalent Input Noise Voltage	e <sub>N</sub>	f=1KHz	--	27	--	nV/√Hz
		f=10KHz	--	20	--	

Typical Characteristic Curves

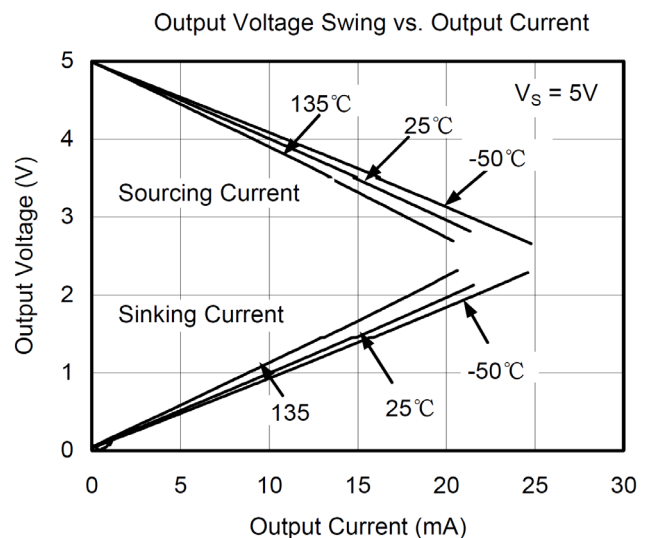
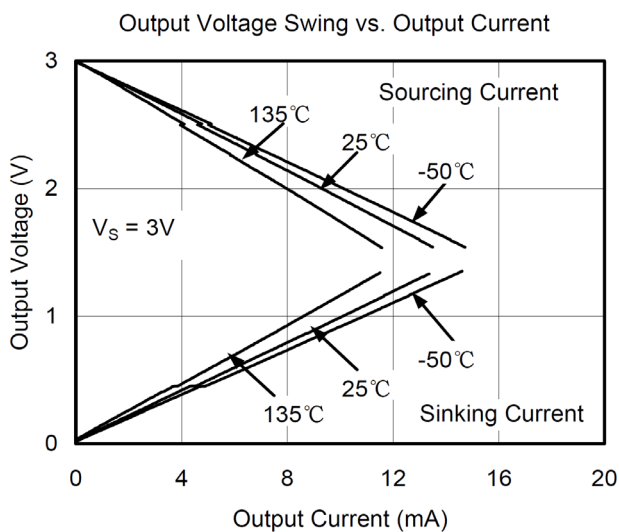
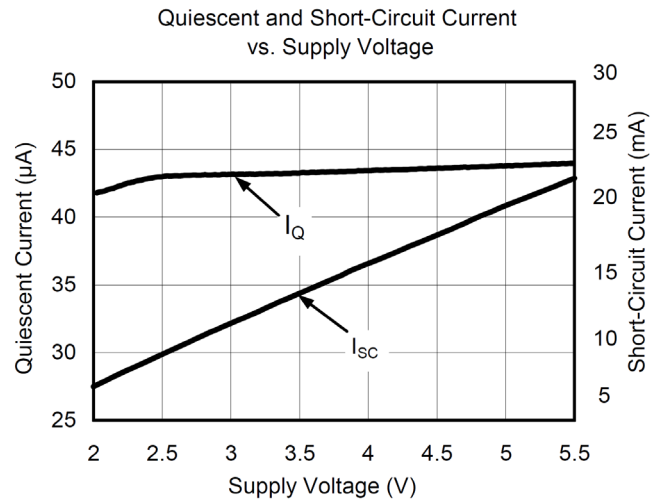
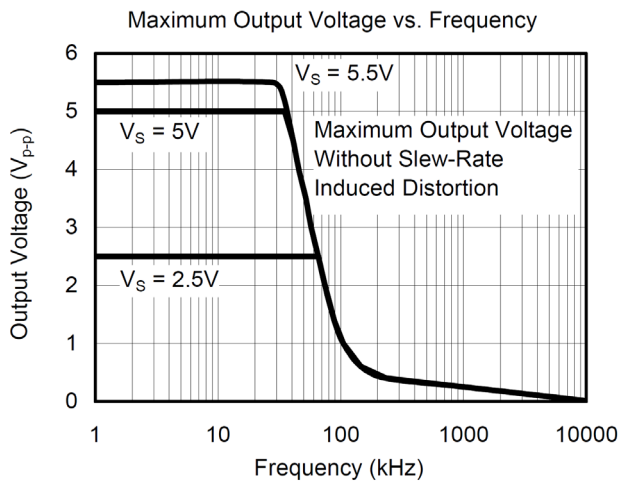
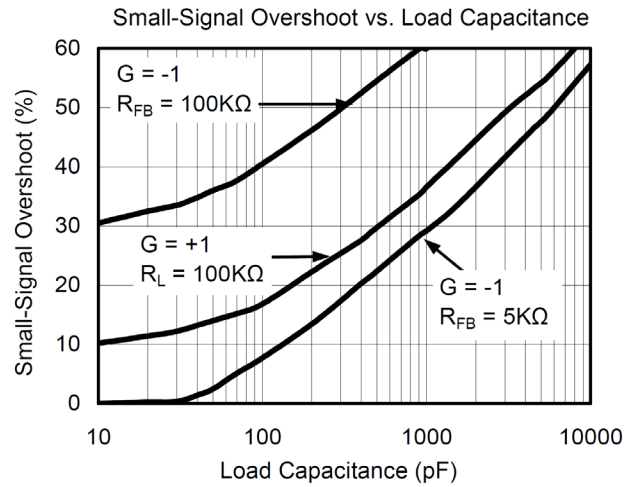
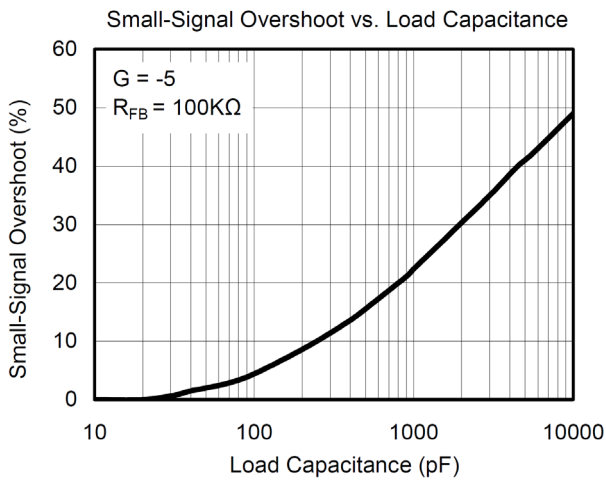

Low-Power rail-to-rail Operational Amplifier

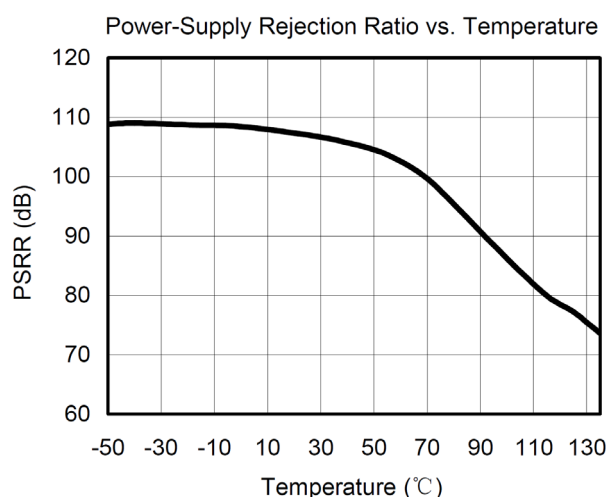
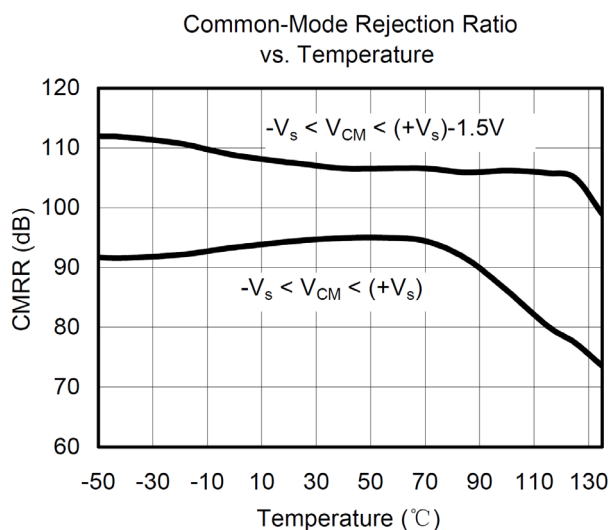
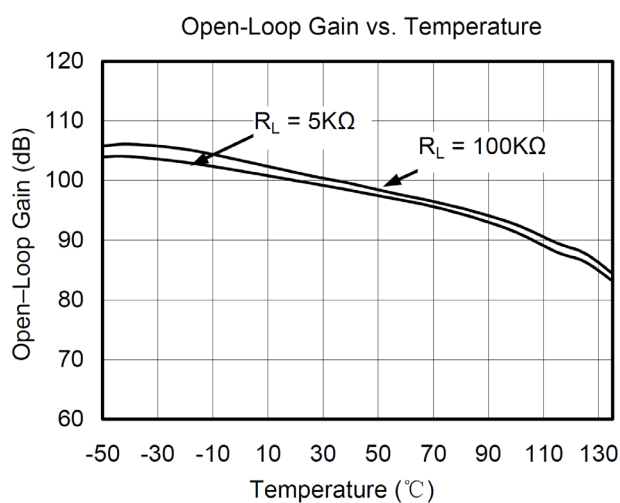
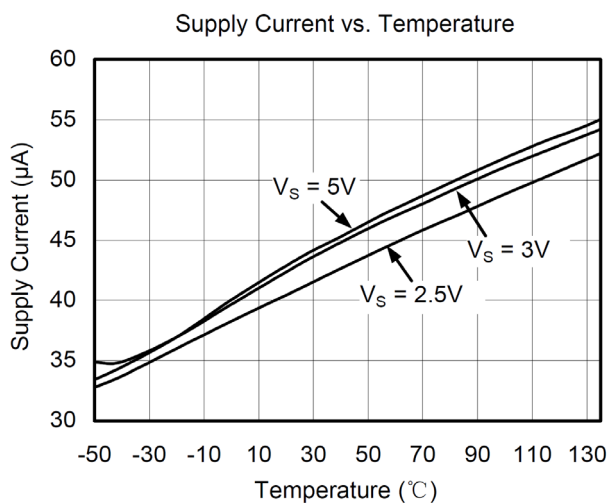

Typical applications

1. differential amplifier

As shown in the figure, if the resistance is equal, ( $R_4 / R_3 = R_2 / R_1$ ), then the output  $V_{OUT} =$

$$(V_p - V_n) \times R_2 / R_1 + V_{REF}$$

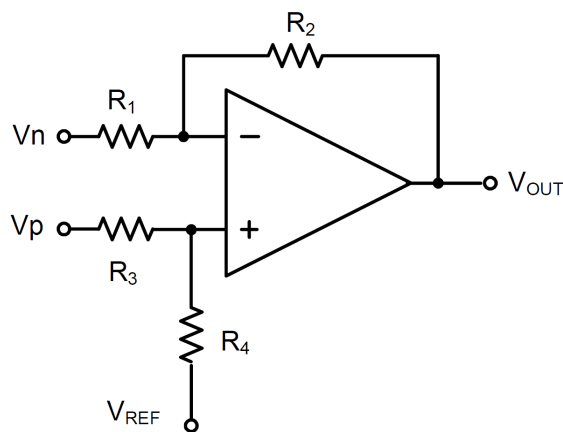

Low-Power rail-to-rail Operational Amplifier

2. instrumentation amplifier

The circuit in the figure above performs the same function, but the input is high impedance.

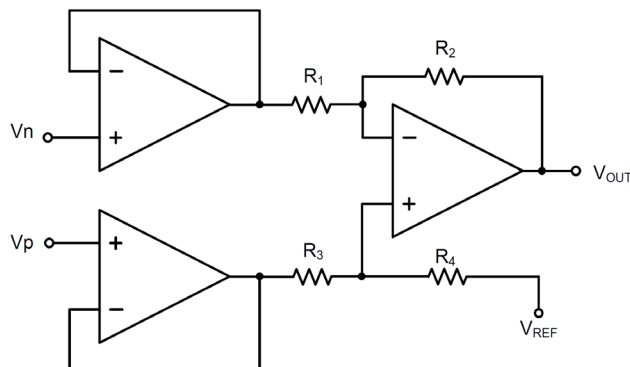

3. Low pass active filtering

The low-pass filter circuit shown here has a  $(-R_2 / R_1)$  DC gain and  $-3\text{db}$  at a frequency of  $1/2 \text{ PI R2C}$  corner. Make sure the filter is within the amplifier's bandwidth. Large feedback resistors are easily accompanied by parasitic capacitance at high speed, resulting in adverse effects such as oscillation. Keep the resistance value as low as possible and consider the appropriate output load.

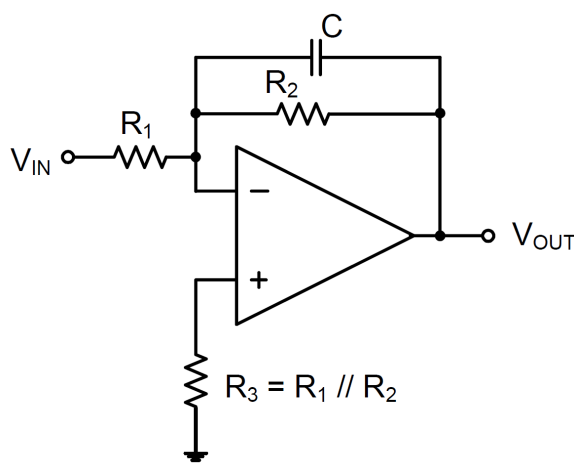

### SC70-5

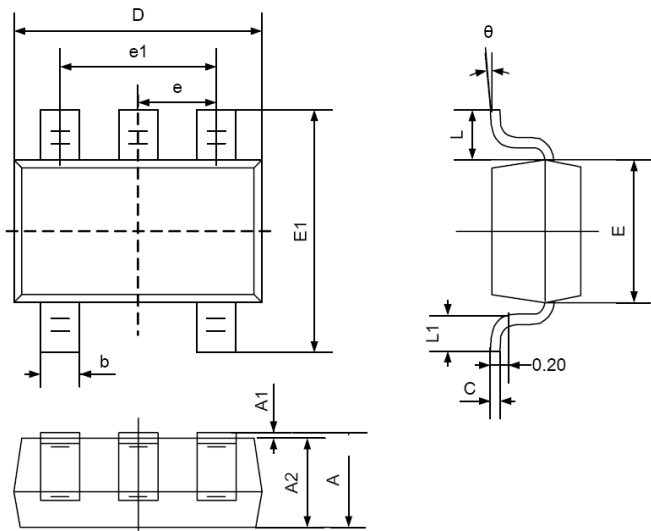

Symbol	Dimensions In Millimeters		Dimensions In Inches	
	Min	Max	Min	Max
A	0.900	1.100	0.035	0.043
A1	0.000	0.100	0.000	0.004
A2	0.900	1.000	0.035	0.039
b	0.150	0.350	0.006	0.014
C	0.080	0.150	0.003	0.006
D	2.000	2.200	0.079	0.087
E	1.150	1.350	0.045	0.053
E1	2.150	2.450	0.085	0.096
e	0.650TYP		0.026TYP	
e1	1.200	1.400	0.047	0.055
L	0.525REF		0.021REF	
L1	0.260	0.460	0.010	0.018
θ	0°	8°	0°	8°

### SOT23-5

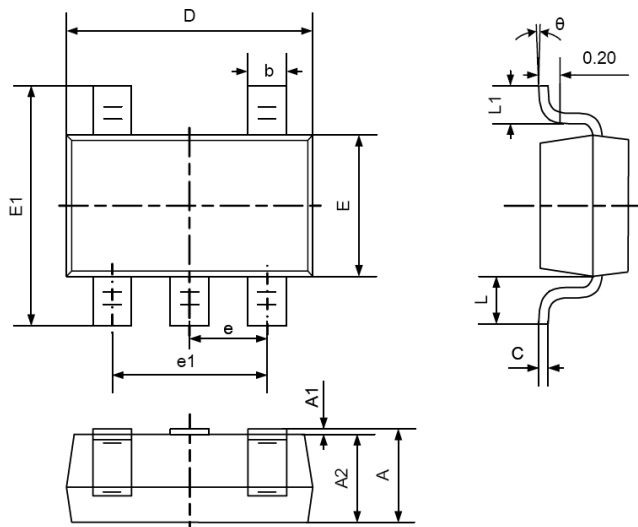

Symbol	Dimensions In Millimeters		Dimensions In Inches	
	Min	Max	Min	Max
A	1.050	1.250	0.041	0.049
A1	0.000	0.100	0.000	0.004
A2	1.050	1.150	0.041	0.045
b	0.300	0.400	0.012	0.016
C	0.100	0.200	0.004	0.008
D	2.820	3.020	0.111	0.119
E	1.500	1.700	0.059	0.067
E1	2.650	2.950	0.104	0.116
e	0.950TYP		0.037TYP	
e1	1.800	2.000	0.071	0.079
L	0.700REF		0.028REF	
L1	0.300	0.460	0.012	0.024
θ	0°	8°	0°	8°

SOP-8

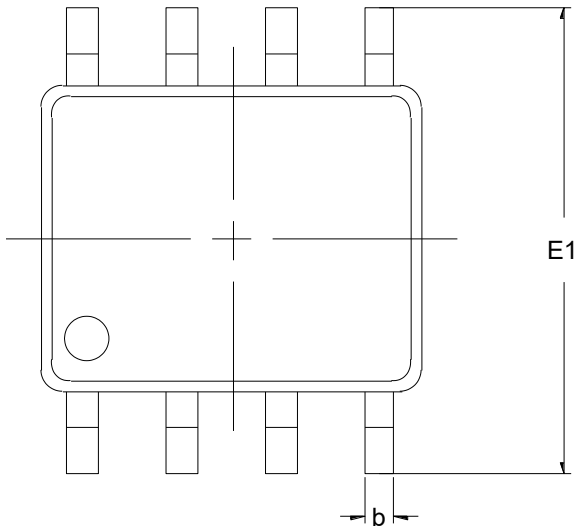
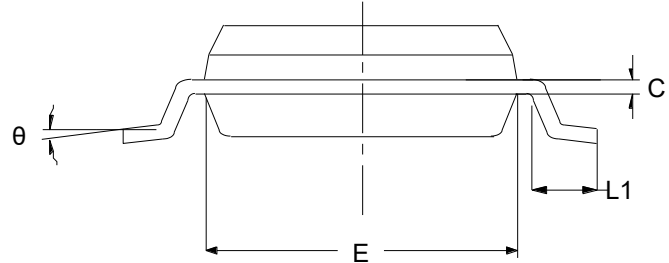
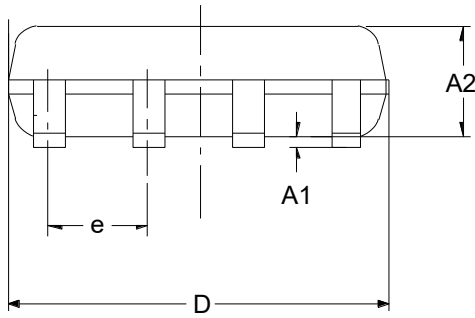

Symbol	Dimensions In Millimeters		Dimensions In Inches	
	Min	Max	Min	Max
A1	0.100	0.250	0.004	0.010
A2	1.350	1.550	0.053	0.061
b	0.330	0.510	0.013	0.020
C	0.190	0.250	0.007	0.010
D	4.780	5.000	0.188	0.197
E	3.800	4.000	0.150	0.157
E1	5.800	6.300	0.228	0.248
e	1.270 TYP		0.050 TYP	
L1	0.400	1.270	0.016	0.050
$\theta$	0°	8°	0°	8°

TSSOP-8

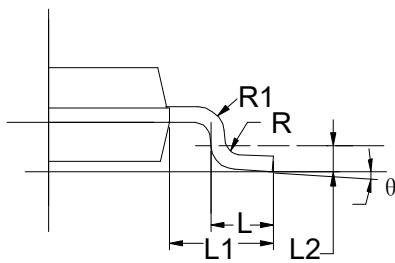
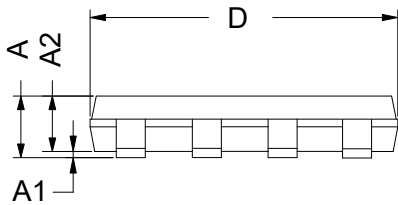
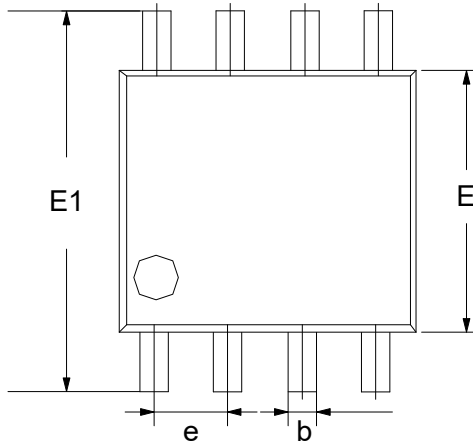

Symbol	Dimensions In Millimeters		Dimensions In Inches	
	Min	Max	Min	Max
A	0.800	1.200	0.031	0.047
A1	0.000	0.200	0.000	0.008
A2	0.760	0.970	0.030	0.038
b	0.30 TYP		0.012 TYP	
C	0.15 TYP		0.006 TYP	
D	2.900	3.100	0.114	0.122
e	0.65 TYP		0.026	
E	2.900	3.100	0.114	0.122
E1	4.700	5.100	0.185	0.201
L1	0.410	0.650	0.016	0.026
θ	0°	6°	0°	6°



TSSOP-14

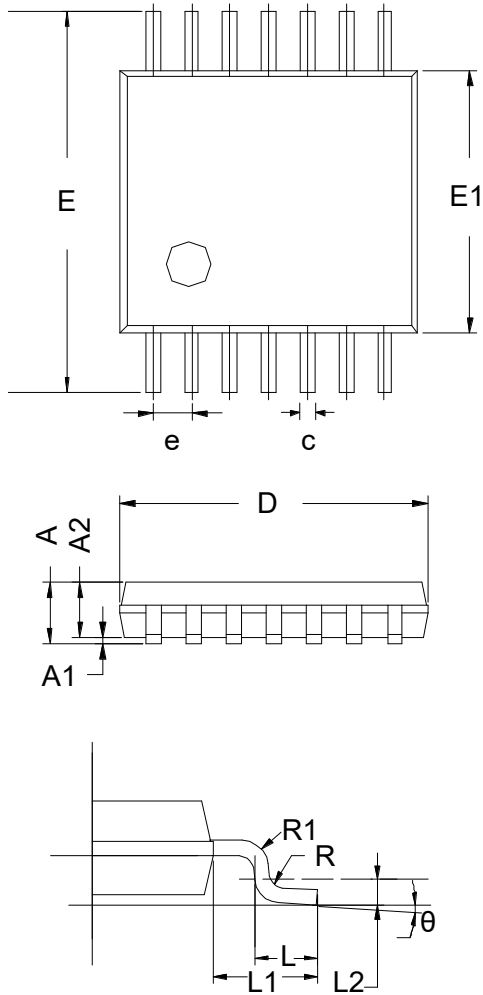

Symbol	Dimensions In Millimeters		
	MIN	TYP	MAX
A	-	-	1.20
A1	0.05	-	0.15
A2	0.90	1.00	1.05
b	0.20	-	0.28
c	0.10	-	0.19
D	4.86	4.96	5.06
E	6.20	6.40	6.60
E1	4.30	4.40	4.50
e	0.65 BSC		
L	0.45	0.60	0.75
L1	1.00 REF		
L2	0.25 BSC		
R	0.09	-	-
$\theta$	0°	-	8°

SOP-14

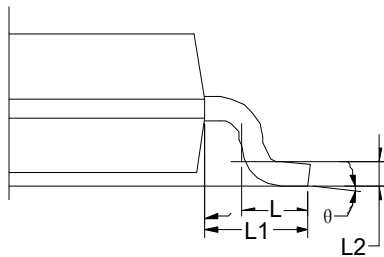
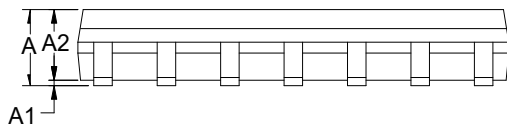
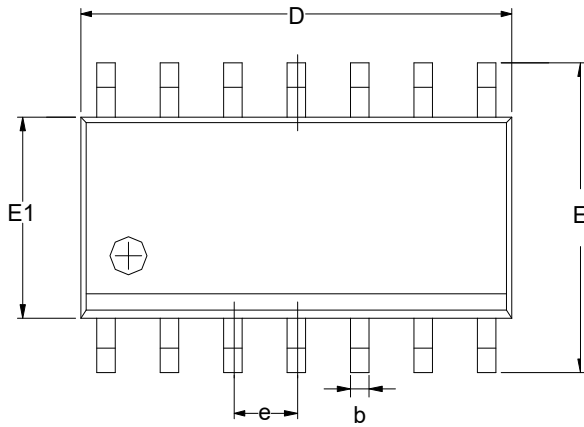

Symbol	Dimensions In Millimeters		
	MIN	TYP	MAX
A	1.35	1.60	1.75
A1	0.10	0.15	0.25
A2	1.25	1.45	1.65
b	0.36		0.49
D	8.53	8.63	8.73
E	5.80	6.00	6.20
E1	3.80	3.90	4.00
e	1.27 BSC		
L	0.45	0.60	0.80
L1	1.04 REF		
L2	0.25 BSC		
θ	0°		8°

**ORDERING INFORMATION**

## X-ON Electronics

Largest Supplier of Electrical and Electronic Components

*Click to view similar products for [Operational Amplifiers - Op Amps](#) category:*

*Click to view products by [Youtai](#) manufacturer:*

Other Similar products are found below :

[430227FB](#) [UPC451G2-A](#) [UPC824G2-A](#) [LT1678IS8](#) [042225DB](#) [058184EB](#) [UPC822G2-A](#) [UPC258G2-A](#) [NCS5651MNTXG](#)  
[NCV33202DMR2G](#) [NJM324E](#) [NTE925](#) [5962-9080901MCA\\*](#) [AZV358MTR-G1](#) [AP4310AUMTR-AG1](#) [HA1630D02MMEL-E](#)  
[HA1630S01LPEL-E](#) [AZV358MMTR-G1](#) [SCY33178DR2G](#) [NJU77806F3-TE1](#) [NCV5652MUTWG](#) [NCV20034DR2G](#) [NTE778S](#) [NTE871](#)  
[NTE924](#) [NTE937](#) [MCP6V16UT-E/OT](#) [MCP6V17T-E/MS](#) [MCP6V19T-E/ST](#) [SCY6358ADR2G](#) [NCS20282FCTTAG](#) [LM4565FVT-GE2](#)  
[EL5420CRZ-T7A](#) [TSV772IQ2T](#) [TSV792IYST](#) [NJM2100M-TE1](#) [COS2262MR](#) [COS2252MR](#) [COS5532SRB](#) [COS2272MR](#) [LMV358MR](#)  
[COS6002MR](#) [LMV358SR](#) [LM358SR](#) [RC4580MM/TR](#) [HGV8544M/TR](#) [HGV8541M/TR](#) [HGV8634M/TR](#) [HGV8542M/TR](#)  
[HGV8544MT/TR](#)