

**Features**

- Ultra Low On-Resistance
  - $R_{DS(ON)} < 63m\Omega$  ( $V_{GS}=10V$ )
  - $R_{DS(ON)} < 71m\Omega$  ( $V_{GS}=5V$ )
- Peak Current vs Pulse Width Curve
- UIS Rating Curve
- Switching Time vs  $R_{GS}$  Curves

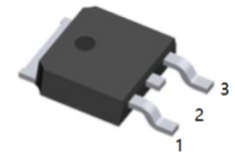

1.G 2.D 3.S  
TO-252(DPAK) top view

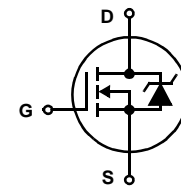

**Absolute Maximum Ratings**  $T_C = 25^{\circ}C$ , Unless Otherwise Specified

Rating	Symbol	Value	Unit
Drain to Source Voltage (Note 1)	$V_{DSS}$	60	V
Drain to Gate Voltage ( $R_{GS} = 20k\Omega$ ) (Note 1)	$V_{DGR}$	60	V
Gate to Source Voltage	$V_{GS}$	$\pm 16$	V
Drain Current			
Continuous ( $T_C = 25^{\circ}C$ , $V_{GS} = 5V$ )	$I_D$	17	A
Continuous ( $T_C = 25^{\circ}C$ , $V_{GS} = 10V$ ) (Figure 2)	$I_D$	18	A
Continuous ( $T_C = 135^{\circ}C$ , $V_{GS} = 5V$ )	$I_D$	8	A
Continuous ( $T_C = 135^{\circ}C$ , $V_{GS} = 4.5V$ ) (Figure 2)	$I_D$	8	A
Pulsed Drain Current	DM	Figure 4	
Pulsed Avalanche Rating	UIS	Figures 6, 17, 18	
Power Dissipation	$P_D$	49	W
Derate Above $25^{\circ}C$		0.327	W/ $^{\circ}C$
Operating and Storage Temperature	$T_J, T_{STG}$	-55 to 175	$^{\circ}C$
Maximum Temperature for Soldering	$T_L$	300	$^{\circ}C$
Leads at 0.063in (1.6mm) from Case for 10s	$T_{pkg}$	260	$^{\circ}C$

NOTE:

1.  $T_J = 25^{\circ}C$  to  $150^{\circ}C$ .

**CAUTION:** Stresses above those listed in "Absolute Maximum Ratings" may cause permanent damage to the device. This is a stress only rating and operation of the device at these or any other conditions above those indicated in the operational sections of this specification is not implied.

**Electrical Specifications**  $T_C = 25^\circ\text{C}$ , Unless Otherwise Specified

PARAMETER	SYMBOL	TEST CONDITIONS	MIN	TYP	MAX	UNITS
<b>OFF STATE SPECIFICATIONS</b>						
Drain to Source Breakdown Voltage	$BV_{DSS}$	$I_D = 250\mu\text{A}$ , $V_{GS} = 0\text{V}$ (Figure 12)	60			V
		$I_D = 250\mu\text{A}$ , $V_{GS} = 0\text{V}$ , $T_C = -40^\circ\text{C}$ (Figure 12)	60			V
Zero Gate Voltage Drain Current	$I_{DSS}$	$V_{DS} = 55\text{V}$ , $V_{GS} = 0\text{V}$			1	$\mu\text{A}$
		$V_{DS} = 50\text{V}$ , $V_{GS} = 0\text{V}$ , $T_C = 150^\circ\text{C}$			250	$\mu\text{A}$
Gate to Source Leakage Current	$I_{GSS}$	$V_{GS} = \pm 16\text{V}$			$\pm 100$	nA
<b>ON STATE SPECIFICATIONS</b>						
Gate to Source Threshold Voltage	$V_{GS(TH)}$	$V_{GS} = V_{DS}$ , $I_D = 250\mu\text{A}$ (Figure 11)	1		2.1	V
Drain to Source On Resistance	$R_{DS(ON)}$	$I_D = 18\text{A}$ , $V_{GS} = 10\text{V}$ (Figures 9, 10)	52		63	$\text{m}\Omega$
		$I_D = 8\text{A}$ , $V_{GS} = 5\text{V}$ (Figure 9)		60	71	$\text{m}\Omega$
		$I_D = 8\text{A}$ , $V_{GS} = 4.5\text{V}$ (Figure 9)		64	75	$\text{m}\Omega$
<b>THERMAL SPECIFICATIONS</b>						
Thermal Resistance Junction to Case	$R_{\theta JC}$	TO-252AA			3.06	$^\circ\text{C}/\text{W}$
Thermal Resistance Junction to Ambient	$R_{\theta JA}$				100	$^\circ\text{C}/\text{W}$
<b>SWITCHING SPECIFICATIONS</b> ( $V_{GS} = 4.5\text{V}$ )						
Turn-On Time	$t_{ON}$	$V_{DD} = 30\text{V}$ , $I_D = 8\text{A}$ $V_{GS} = 4.5\text{V}$ , $R_{GS} = 22\Omega$ (Figures 15, 21, 22)			153	ns
Turn-On Delay Time	$t_{d(ON)}$			13		ns
Rise Time	$t_r$			89		ns
Turn-Off Delay Time	$t_{d(OFF)}$			22		ns
Fall Time	$t_f$			37		ns
Turn-Off Time	$t_{OFF}$				89	ns
<b>SWITCHING SPECIFICATIONS</b> ( $V_{GS} = 10\text{V}$ )						
Turn-On Time	$t_{ON}$	$V_{DD} = 30\text{V}$ , $I_D = 18\text{A}$ $V_{GS} = 10\text{V}$ , $R_{GS} = 24\Omega$ (Figures 16, 21, 22)			59	ns
Turn-On Delay Time	$t_{d(ON)}$			5.3		ns
Rise Time	$t_r$			34		ns
Turn-Off Delay Time	$t_{d(OFF)}$			41		ns
Fall Time	$t_f$			50		ns
Turn-Off Time	$t_{OFF}$				136	ns
<b>GATE CHARGE SPECIFICATIONS</b>						
Total Gate Charge	$Q_{g(TOT)}$	$V_{GS} = 0\text{V}$ to $10\text{V}$ $V_{DD} = 30\text{V}$ , $I_D = 8\text{A}$ , $I_{g(REF)} = 1.0\text{mA}$ (Figures 14, 19, 20)		12	15	nC
Gate Charge at 5V	$Q_{g(5)}$			6.8	8.2	nC
Threshold Gate Charge	$Q_{g(TH)}$			0.54	0.65	nC
Gate to Source Gate Charge	$Q_{gs}$			1.7		nC
Gate to Drain "Miller" Charge	$Q_{gd}$			3		nC
<b>CAPACITANCE SPECIFICATIONS</b>						
Input Capacitance	$C_{ISS}$	$V_{DS} = 25\text{V}$ , $V_{GS} = 0\text{V}$ , $f = 1\text{MHz}$ (Figure 13)		485		pF
Output Capacitance	$C_{OSS}$			130		pF
Reverse Transfer Capacitance	$C_{RSS}$			28		pF

**Source to Drain Diode Specifications**

PARAMETER	SYMBOL	TEST CONDITIONS	MIN	TYP	MAX	UNITS
Source to Drain Diode Voltage	$V_{SD}$	$I_{SD} = 8\text{A}$			1.25	V
		$I_{SD} = 4\text{A}$			1.0	V
Reverse Recovery Time	$t_{rr}$	$I_{SD} = 8\text{A}$ , $dI_{SD}/dt = 100\text{A}/\mu\text{s}$			70	ns
Reverse Recovered Charge	$Q_{RR}$	$I_{SD} = 8\text{A}$ , $dI_{SD}/dt = 100\text{A}/\mu\text{s}$			165	nC

Typical Performance Curves

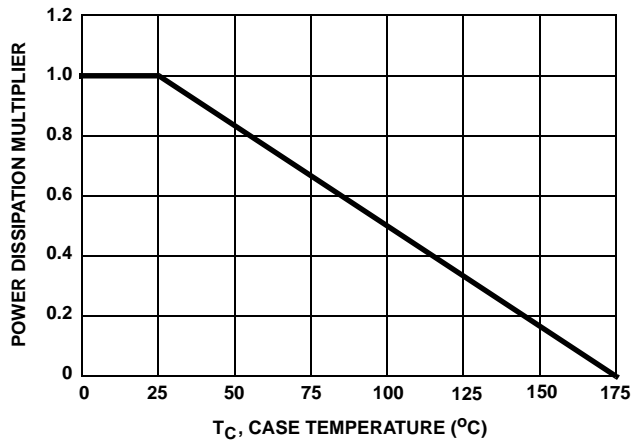

FIGURE 1. NORMALIZED POWER DISSIPATION vs CASE TEMPERATURE

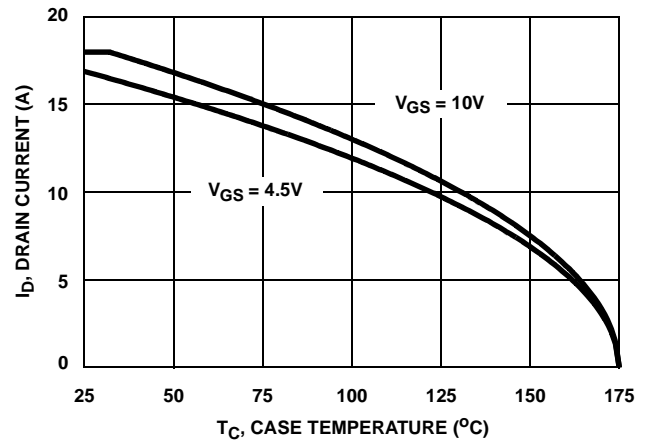

FIGURE 2. MAXIMUM CONTINUOUS DRAIN CURRENT vs CASE TEMPERATURE

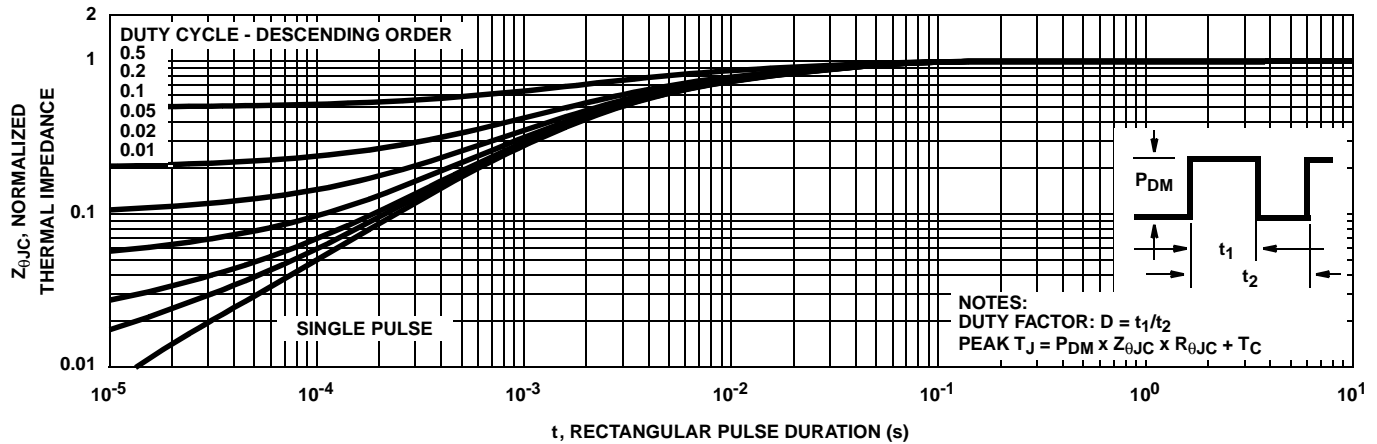

FIGURE 3. NORMALIZED MAXIMUM TRANSIENT THERMAL IMPEDANCE

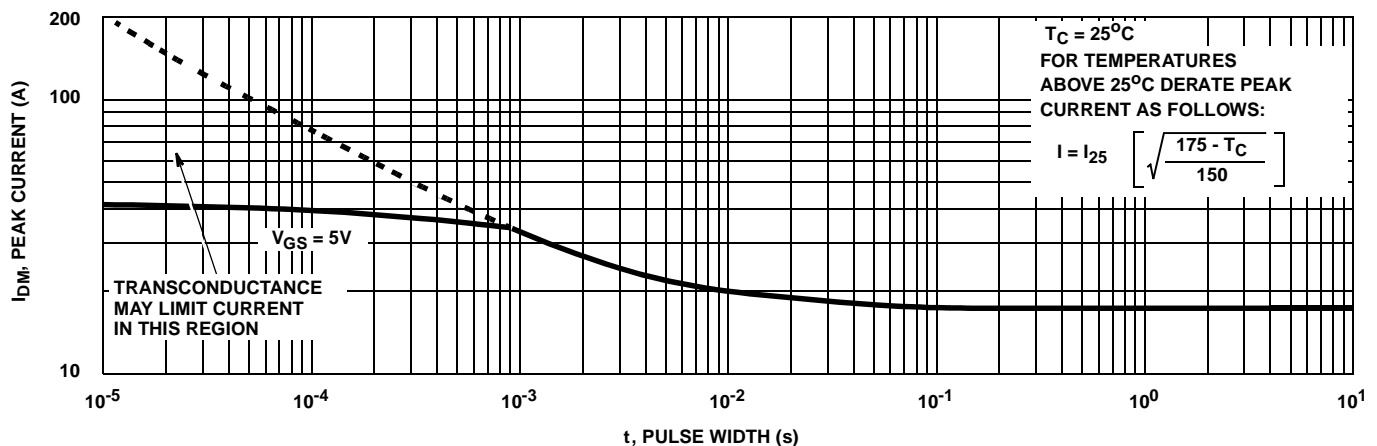

FIGURE 4. PEAK CURRENT CAPABILITY

Typical Performance Curves (Continued)

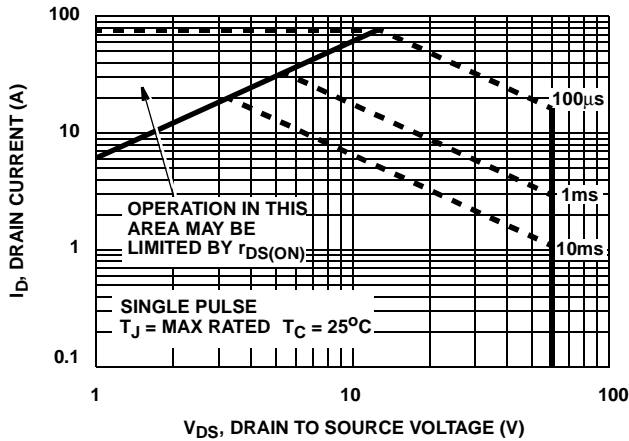

FIGURE 5. FORWARD BIAS SAFE OPERATING AREA

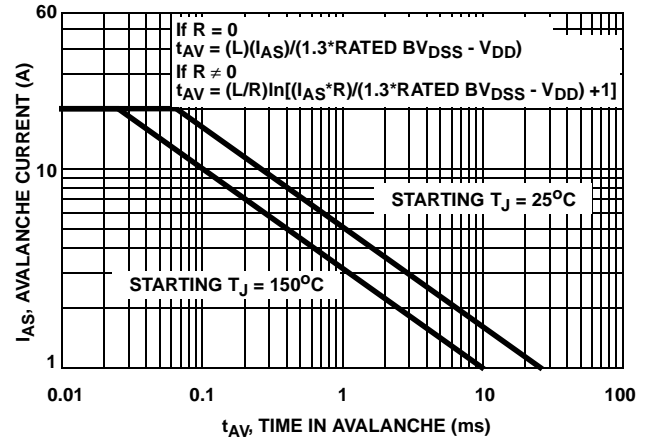

FIGURE 6. UNCLAMPED INDUCTIVE SWITCHING CAPABILITY

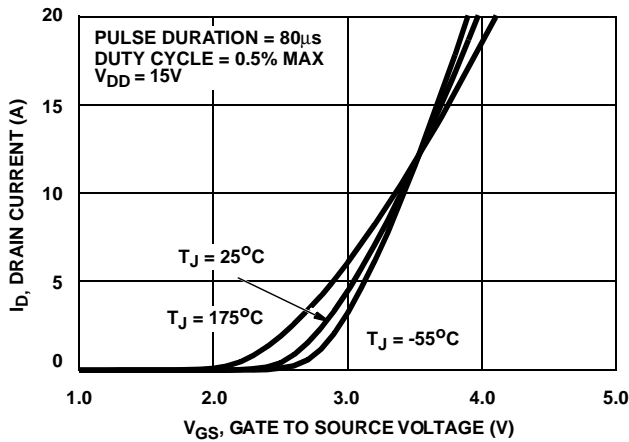

FIGURE 7. TRANSFER CHARACTERISTICS

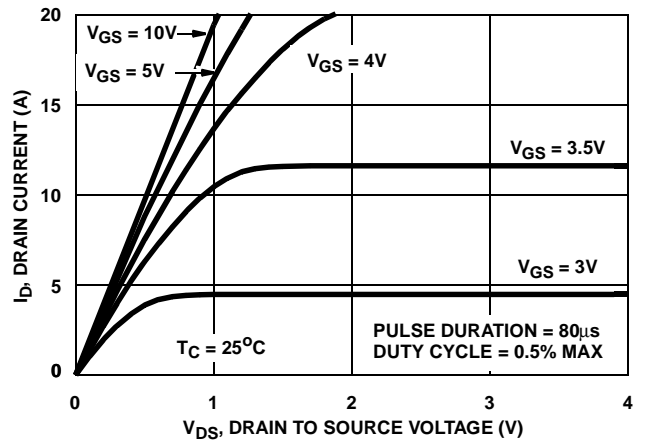

FIGURE 8. SATURATION CHARACTERISTICS

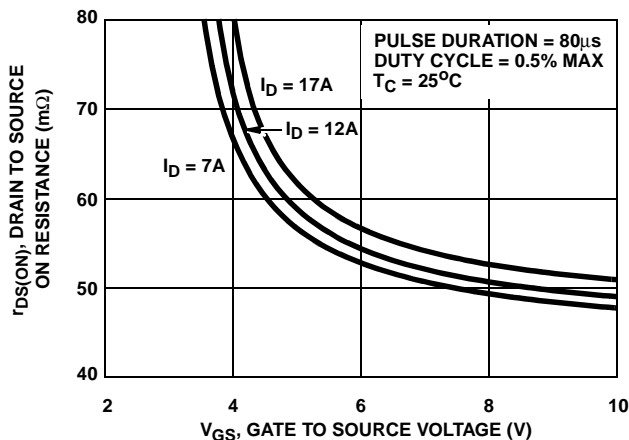

FIGURE 9. DRAIN TO SOURCE ON RESISTANCE vs GATE VOLTAGE AND DRAIN CURRENT

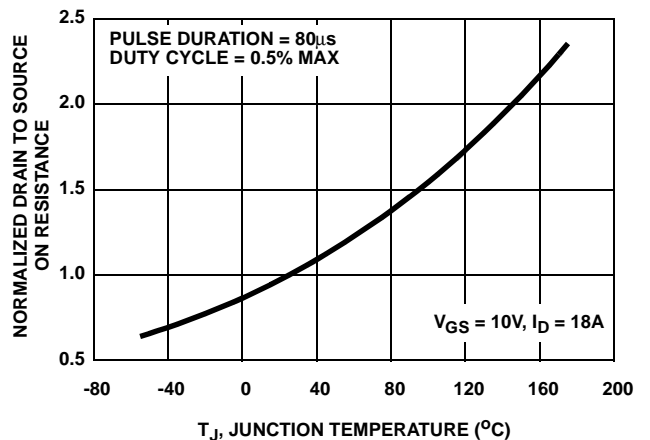

FIGURE 10. NORMALIZED DRAIN TO SOURCE ON RESISTANCE vs JUNCTION TEMPERATURE

Typical Performance Curves

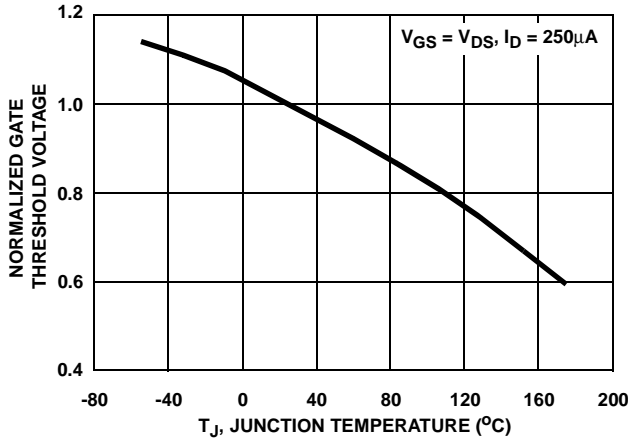

FIGURE 11. NORMALIZED GATE THRESHOLD VOLTAGE vs JUNCTION TEMPERATURE

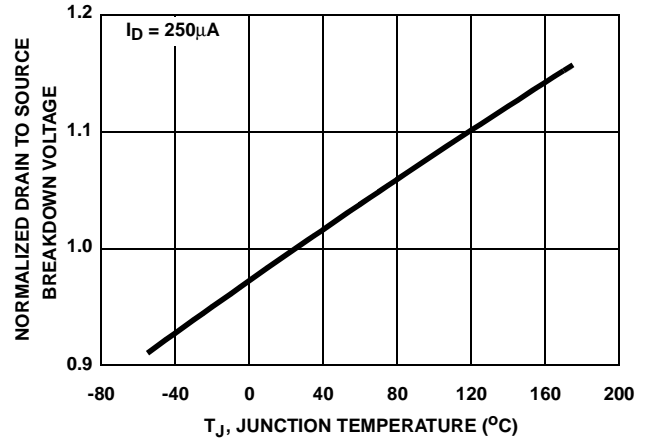

FIGURE 12. NORMALIZED DRAIN TO SOURCE BREAKDOWN VOLTAGE vs JUNCTION TEMPERATURE

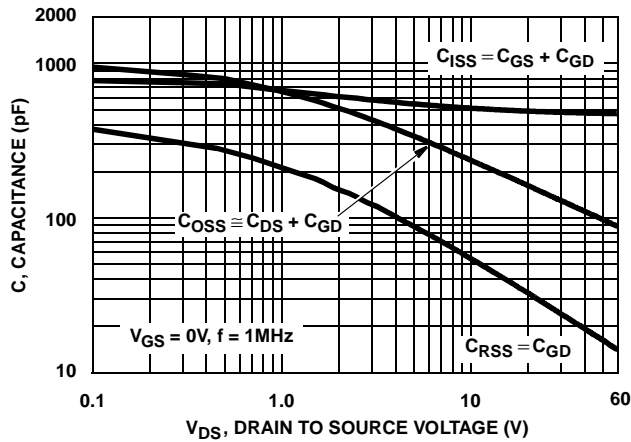

FIGURE 13. CAPACITANCE vs DRAIN TO SOURCE VOLTAGE

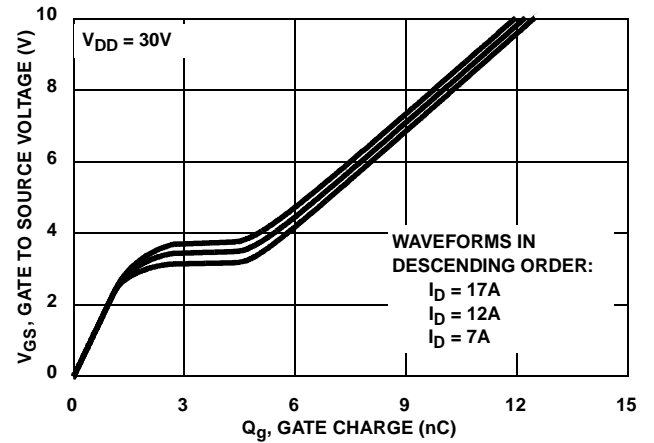

FIGURE 14. GATE CHARGE WAVEFORMS FOR CONSTANT GATE CURRENT

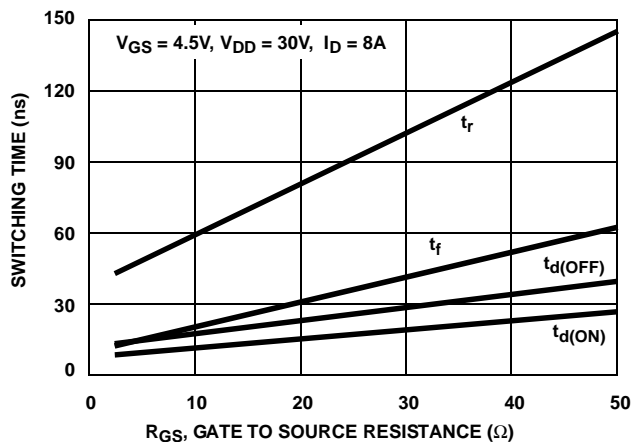

FIGURE 15. SWITCHING TIME vs GATE RESISTANCE

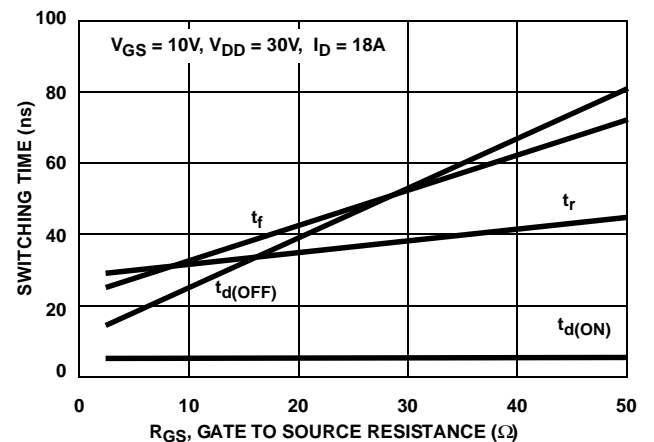

FIGURE 16. SWITCHING TIME vs GATE RESISTANCE

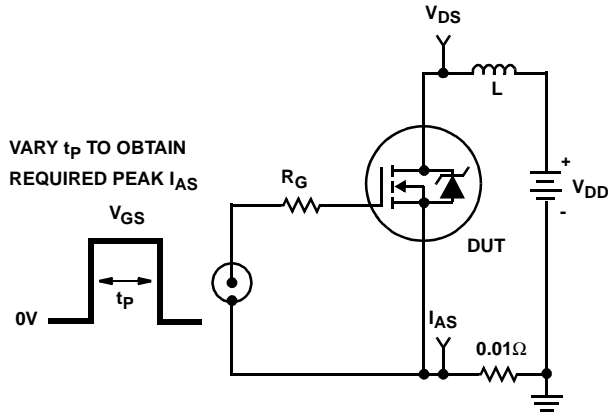

FIGURE 17. UNCLAMPED ENERGY TEST CIRCUIT

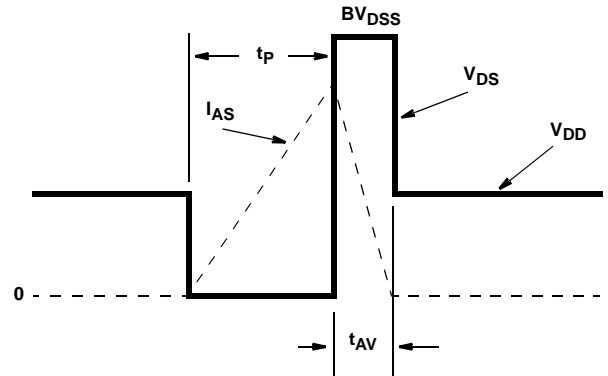

FIGURE 18. UNCLAMPED ENERGY WAVEFORMS

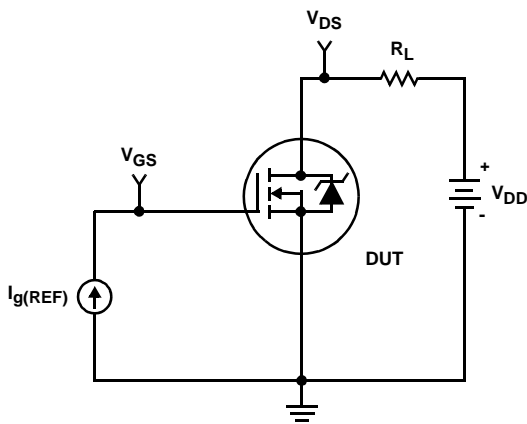

FIGURE 19. GATE CHARGE TEST CIRCUIT

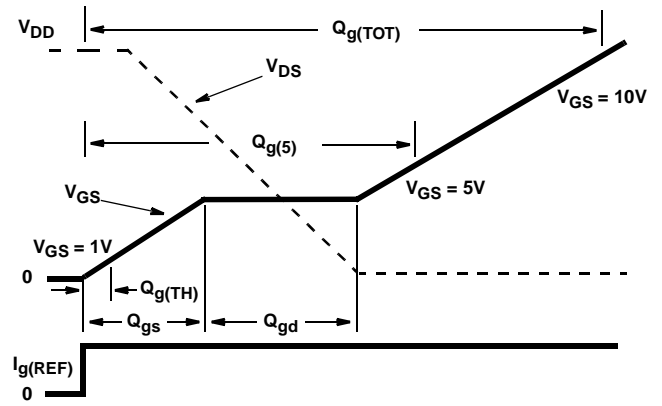

FIGURE 20. GATE CHARGE WAVEFORMS

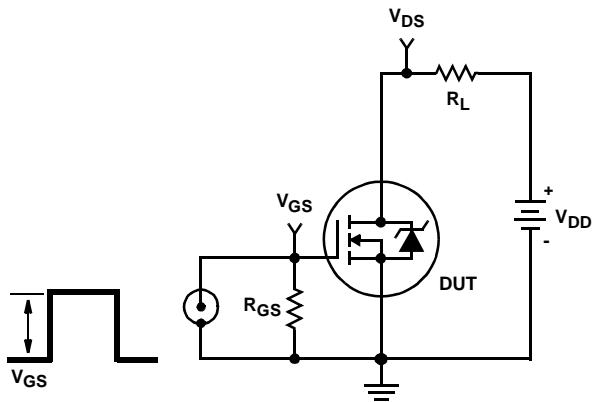

FIGURE 21. SWITCHING TIME TEST CIRCUIT

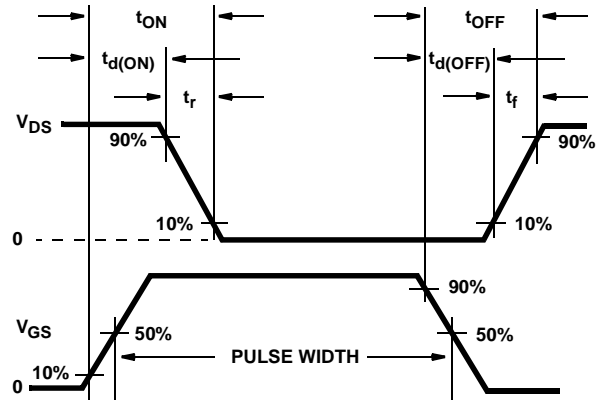
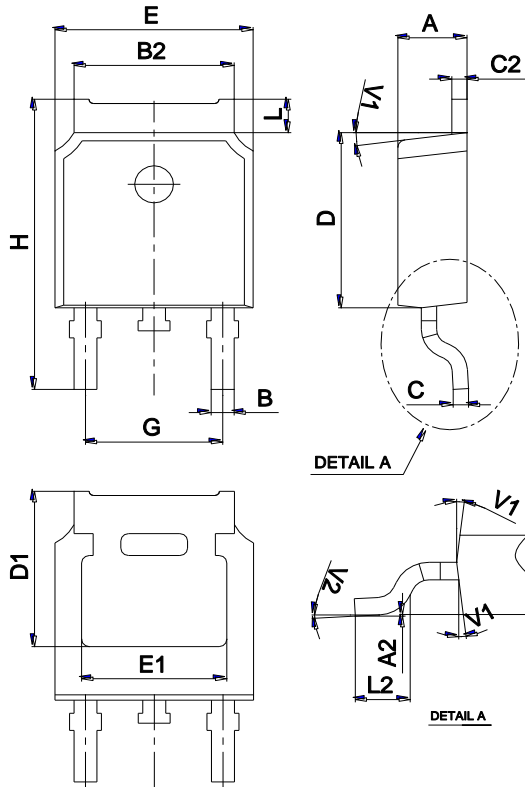

FIGURE 22. SWITCHING TIME WAVEFORM

Package Mechanical Data TO-252



Ref.	Dimensions					
	Millimeters			Inches		
	Min.	Typ.	Max.	Min.	Typ.	Max.
A	2.10		2.50	0.083		0.098
A2	0		0.10	0		0.004
B	0.66		0.86	0.026		0.034
B2	5.18		5.48	0.202		0.216
C	0.40		0.60	0.016		0.024
C2	0.44		0.58	0.017		0.023
D	5.90		6.30	0.232		0.248
D1	5.30REF			0.209REF		
E	6.40		6.80	0.252		0.268
E1	4.63			0.182		
G	4.47		4.67	0.176		0.184
H	9.50		10.70	0.374		0.421
L	1.09		1.21	0.043		0.048
L2	1.35		1.65	0.053		0.065
V1		7°			7°	
V2	0°		6°	0°		6°

Marking

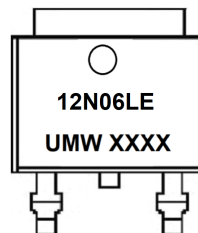

Ordering information

Order code	Package	Baseqty	Deliverymode
UMW RFD12N06RLESM9A	TO-252	2500	Tape and reel

## X-ON Electronics

Largest Supplier of Electrical and Electronic Components

*Click to view similar products for [MOSFET](#) category:*

*Click to view products by [Youtai](#) manufacturer:*

Other Similar products are found below :

[IRFD120](#) [JANTX2N5237](#) [2SK2267\(Q\)](#) [BUK455-60A/B](#) [TK100A10N1,S4X\(S](#) [MIC4420CM-TR](#) [VN1206L](#) [NDP4060](#) [SI4482DY](#)  
[IRS2092STRPBF-EL](#) [IPS70R2K0CEAKMA1](#) [TK31J60W5,S1VQ\(O](#) [TK31J60W,S1VQ\(O](#) [TK16J60W,S1VQ\(O](#) [2SK2614\(TE16L1,Q\)](#)  
[DMN1017UCP3-7](#) [EFC2J004NUZTDG](#) [P85W28HP2F-7071](#) [DMN1053UCP4-7](#) [NTE2384](#) [DMC2700UDMQ-7](#) [DMN2080UCB4-7](#)  
[DMN61D9UWQ-13](#) [US6M2GTR](#) [DMN31D5UDJ-7](#) [DMP22D4UFO-7B](#) [IPS60R3K4CEAKMA1](#) [DMN1006UCA6-7](#) [DMN16M9UCA6-7](#)  
[STF5N65M6](#) [IRF40H233XTMA1](#) [STU5N65M6](#) [DMN6022SSD-13](#) [DMN13M9UCA6-7](#) [DMTH10H4M6SPS-13](#) [IPS60R360PFD7SAKMA1](#)  
[DMN2990UFB-7B](#) [SSM3K35CT,L3F](#) [IPLK60R1K0PFD7ATMA1](#) [2N7002W-G](#) [MCAC30N06Y-TP](#) [IPWS65R035CFD7AXKSA1](#)  
[MCQ7328-TP](#) [SSM3J143TU,LXHF](#) [DMN12M3UCA6-7](#) [PJMF280N65E1\\_T0\\_00201](#) [PJMF380N65E1\\_T0\\_00201](#)  
[PJMF280N60E1\\_T0\\_00201](#) [PJMF600N65E1\\_T0\\_00201](#) [PJMF900N65E1\\_T0\\_00201](#)