

General Description

The SN74AUP1G08 is a single 2-input AND Gate operating from a 0.8V to 3.6V supply. This device is fabricated with advanced CMOS technology to achieve ultra-high speed with high output drive.

Features

- Designed for 0.8V to 3.6V VCC Operation
- Low static power consumption; I_{cc} = 0.7µA (maximum)
- 4mA Balanced Output Sink and Source Capability
- Near Zero Static Supply Current Substantially Reduces System Power Requirements
- These Devices are Pb-Free and are RoHS Compliant

Pin Configuration

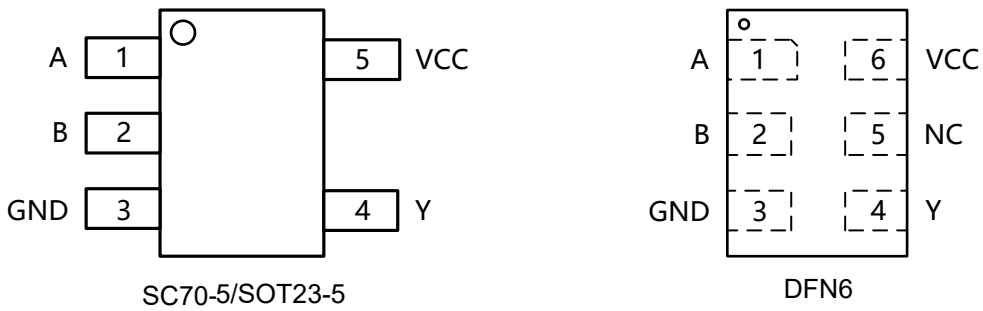

Figure1. Top View

Pin Function

Pin No.		Function
SC70-5	DFN6	
1	1	A
2	2	B
3	3	GND
4	4	Y
/	5	NC
5	6	VCC

Block Diagram

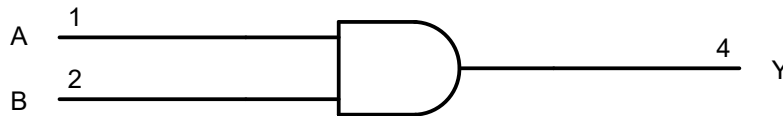

Figure2. Logic Symbol

Functional Description

Function Table

Input		Output
A	B	Y
L	L	L
L	H	L
H	L	L
H	H	H

Absolute Maximum Ratings

Symbol	Parameter		Value	Unit
V _{CC}	DC Supply Voltage		-0.5 to 4.6	V
V _I	DC Input Voltage		-0.5 ≤ V _I ≤ +4.6	V
V _O	DC Output Voltage Output in Higher or Low State		-0.5 to 4.6	V
I _{IK}	DC Input Diode Current	V _I < GND	-50	mA
I _{OK}	DC Output Diode Current	V _O < GND, V _O > V _{CC}	±50	mA
I _O	DC Output Sink Current		±20	mA
I _{CC}	DC Supply Current per Supply Pin		±50	mA
I _{GND}	DC Ground Current per Supply Pin		±50	mA
T _{STG}	Storage Temperature Range		-65 to 150	°C
T _L	Lead Temperature, 1 mm from Case for 10 Seconds		260	°C
T _J	Junction Temperature Under Bias		150	°C
ESD	ESD Classification	Human Body Model ⁽²⁾	4000	V
		Machine Model ⁽³⁾	200	
		Charged Device Model ⁽⁴⁾	800	
I _{LU}	Latchup Current Above V _{CC} and GND at 125°C ⁽⁵⁾		±100	mA

Stresses exceeding those listed in this table may damage the device. If any of these limits are exceeded, device functionality should not be assumed, damage may occur and reliability may be affected.

Note1. IO absolute maximum rating must be observed.

Note2. Tested to EIA/JESD22-A114-A.

Note3. Tested to EIA/JESD22-A115-A.

Note4. Tested to JESD22-C101-A.

Note5. Tested to EIA/JESD78.

Thermal Characteristics

Symbol	Package	Ratings	Value	Unit
R _{θJA}	SC70-5	Thermal Characteristics, Thermal Resistance, Junction-to-Air	300	°C/W
	DFN6(1×1.5)		440	
	DFN6(1×1)		440	
R _{θJB}	SC70-5	Thermal Characteristics, Thermal Resistance, Junction-to-board	75	°C/W
	DFN6(1×1.5)		270	
	DFN6(1×1)		285	
P _D	SC70-5	Power Dissipation in Still Air at 85°C	215	mW
	DFN6(1×1.5)		260	
	DFN6(1×1)		150	

Recommended Operating Conditions

Symbol	Parameter	Min	Max	Unit
V _{CC}	DC Supply Voltage Operating	0.8	3.6	V
V _{IN}	DC Input Voltage	0	3.6	V
V _{OUT}	DC Output Voltage (High or Low State)	0	3.6	V
T _A	Operating Temperature Range	-40	85	°C
t _r ,t _f	Input Rise and Fall Time	V _{CC} = 0.8V to 3.6V		ns/V

Functional operation above the stresses listed in the Recommended Operating Ranges is not implied.

Electrical Characteristics
DC Electrical Characteristics

Symbol	Parameter	Condition	V _{CC} (V)	T _A = 25°C			-40°C ≤ T _A ≤ 125°C		Unit
				Min	Typ	Max	Min	Max	
V _{IH}	High-Level Input Voltage		0.8V	0.75V _{CC}			0.75V _{CC}		V
			0.9 to 1.95V	0.7V _{CC}			0.7V _{CC}		
			2.3 to 2.7V	1.6			1.6		
			3.0 to 3.6V	2.0			2.0		
V _{IL}	Low-Level Input Voltage		0.8V			0.25V _{CC}		0.25V _{CC}	V
			0.9 to 1.95V			0.3V _{CC}		0.3V _{CC}	
			2.3 to 2.7V			0.7		0.7	
			3.0 to 3.6V			0.9		0.9	
V _{OH}	High-Level Output Voltage	I _{OH} =-20uA	0.8 to 3.6V	V _{CC} -0.1			V _{CC} -0.1		V
		I _{OH} =-1.1mA	1.1	0.82	1.02		0.77		
		I _{OH} =-1.7mA	1.4	1.11	1.32		1.03		
		I _{OH} =-1.9mA	1.65	1.32	1.58		1.30		
		I _{OH} =-2.3mA	2.3	2.05	2.24		1.97		
		I _{OH} =-3.1mA		1.9	2.22		1.85		
		I _{OH} =-2.7mA	3.0	2.72	2.95		2.67		
		I _{OH} =-4.0mA		2.6	2.92		2.55		
V _{OL}	Low-Level Output Voltage	I _{OL} =20uA	0.8 to 3.6V			0.1		0.1	V
		I _{OL} =1.1mA	1.1		0.11	0.33		0.33	
		I _{OL} =1.7mA	1.4		0.12	0.31		0.37	
		I _{OL} =1.9mA	1.65		0.11	0.31		0.35	
		I _{OL} =2.3mA	2.3		0.14	0.31		0.33	
		I _{OL} =3.1mA			0.19	0.44		0.45	
		I _{OL} =2.7mA	3.0		0.11	0.31		0.33	
		I _{OL} =4.0mA			0.16	0.44		0.45	
I _{IN}	Input Leakage Current	V _{IN} = V _{CC} or GND	0 to 3.6V			±0.1		±0.2	uA

I_{OFF}	Power Off Leakage Current	$V_{IN} = 3.6\text{ V}$ or $V_{OUT} = 3.6\text{ V}$	0			± 0.2		± 0.5	μA
ΔI_{OFF}	Additional Power Off Leakage Current	V_{IN} or $V_{OUT} = 0\sim 3.6\text{ V}$	0~0.2V			± 0.2		± 0.6	μA
I_{CC}	Quiescent Supply Current	$V_{IN} = 3.6\text{ V}$ or GND	3.6			± 0.2		± 0.7	μA
ΔI_{CC}	Additional Quiescent Supply Current	$V_{IN} = 2.7\text{ V}$	3.3V			60		90	μA

Product parametric performance is indicated in the Electrical Characteristics for the listed test conditions, unless otherwise noted. Product performance may not be indicated by the Electrical Characteristics if operated under different conditions.

AC Electrical Characteristics

$t_r = t_f = 2.5\text{ ns}$

Symbol	Parameter	Condition	$V_{CC}(\text{V})$	$T_A = 25^\circ\text{C}$			$-40^\circ\text{C} \leq T_A \leq 125^\circ\text{C}$		Unit
				Min	Typ	Max	Min	Max	
t_{PLH} t_{PHL}	Propagation Delay (Figure3 And 4)	$C_L = 5\text{ pF}^{(6)}$	0.8	13.2	29	90.1	11.9	220	ns
			1.2	5.0	7.6	14.3	4.6	14.4	
			1.5	3.4	4.8	8.9	3	9.6	
			1.8	2.7	3.6	6.9	2.3	7.6	
			2.5	1.9	2.4	5.1	1.6	5.6	
			3.3	1.5	1.9	4.4	1.3	4.8	
		$C_L = 10\text{ pF}^{(6)}$	0.8	14.3	31.3	97.9	12.8	239	ns
			1.2	5.4	8.3	15.3	5.0	15.3	
			1.5	3.7	5.2	9.5	3.2	10.2	
			1.8	2.9	3.9	7.4	2.5	8.1	
			2.5	2.0	2.6	5.4	1.7	6.0	
			3.3	1.6	2.0	4.6	1.3	5.1	
		$C_L = 15\text{ pF}^{(6)}$	0.8	15.3	32.5	106	13.8	259	ns
			1.2	5.8	8.9	16.3	5.3	16.3	
			1.5	4.0	5.6	10.1	3.5	10.9	
			1.8	3.1	4.2	7.8	2.6	8.6	
			2.5	2.1	2.8	5.8	1.8	6.4	
			3.3	1.7	2.2	4.9	1.4	5.4	
		$C_L = 30\text{ pF}^{(6)}$	0.8	18.3	37.5	130	16.6	323	ns

			1.2	7.0	10.7	19.3	6.4	19.3
			1.5	4.8	6.9	12.0	4.2	12.9
			1.8	3.7	5.1	9.2	3.2	10.2
			2.5	2.6	3.5	6.7	2.2	7.5
			3.3	2.0	2.2	5.6	1.7	6.3

Note6. C_L includes probe and jig capacitance.

Capacitance Characteristics

Symbol	Parameter	Condition	Typical	Unit	
C _{IN}	Input Capacitance	V _{CC} = 3.6V, V _I = 0 V or V _{CC}	2	pF	
C _O	output capacitance	V _{CC} = 0V, V _{OUT} = GND	3	pF	
C _{PD}	Power Dissipation Capacitance (7)	1 MHz, V _I = 0 V to V _{CC}	V _{CC} = 0.8V	7.6	pF
			V _{CC} = 1.2V	8.1	
			V _{CC} = 1.5V	8.5	
			V _{CC} = 1.8V	8.6	
			V _{CC} = 2.5V	9.0	
			V _{CC} = 3.3 V	9.6	

Note7. C_{PD} is defined as the value of the internal equivalent capacitance which is calculated from the operating current consumption without load. Average operating current can be obtained by the equation: I_{CC(OPR)}=C_{PD}×V_{CC}×fin+I_{CC}×C_{PD} is used to determine the no-load dynamic power consumption; P_D=C_{PD}×V_{CC}² ×fin+I_{CC}×V_{CC}×Fig.

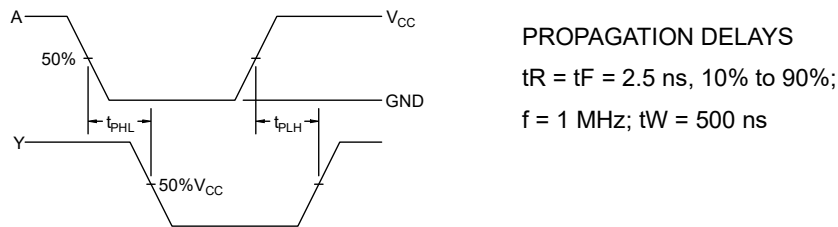
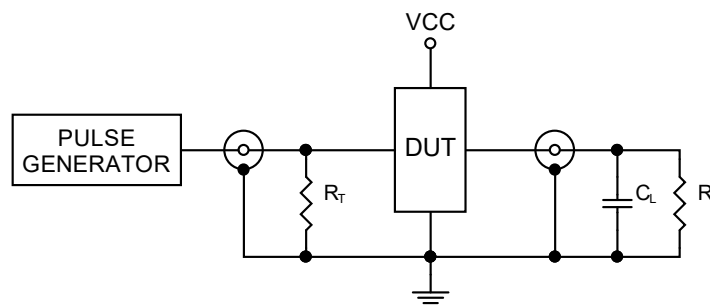

Figure 3. Switching Waveforms



RT=50Ω (typ)

Figure4. Test Circuit

Package Dimension

SC70-5

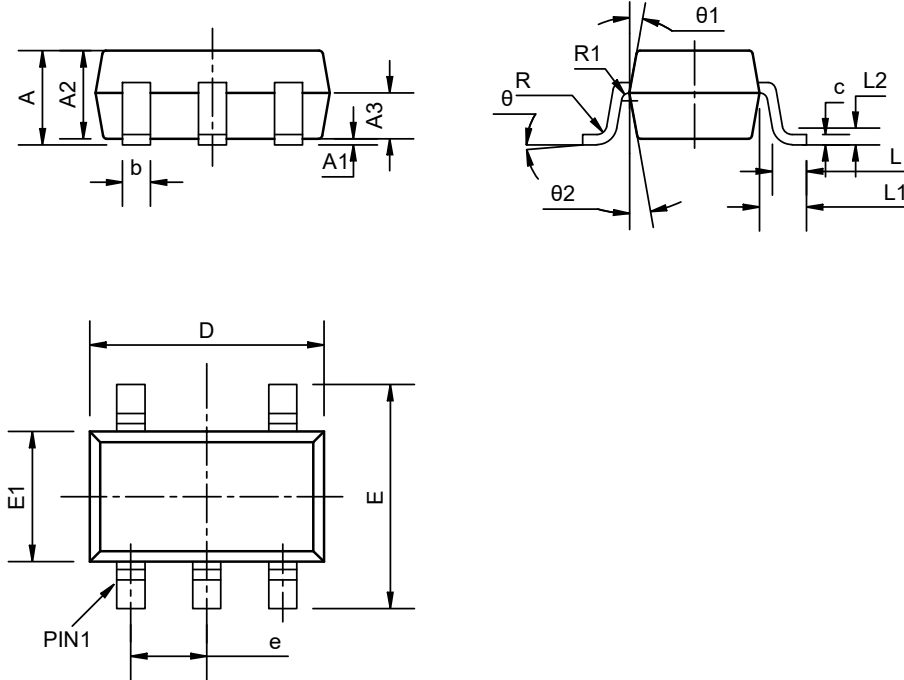

COMMON DIMENSIONS
(UNITS OF MEASURE=MILLIMETER)

SYMBOL	MIN	NOM	MAX
A	0.85	--	1.05
A1	0	--	0.10
A2	0.80	0.90	1.00
A3	0.47	0.52	0.57
b	0.23	--	0.33
c	0.12	--	0.18
D	2.02	2.07	2.12
E	2.20	2.30	2.40
E1	1.25	1.30	1.35
e	0.60	0.65	0.70
L	0.28	0.33	0.38
L1	0.50REF		
L2	0.15BSC		
R	0.10	--	--
R1	0.10	--	0.25
θ	0°	--	8°
θ1	6°	9°	12°
θ2	6°	9°	12°

SOT23-5

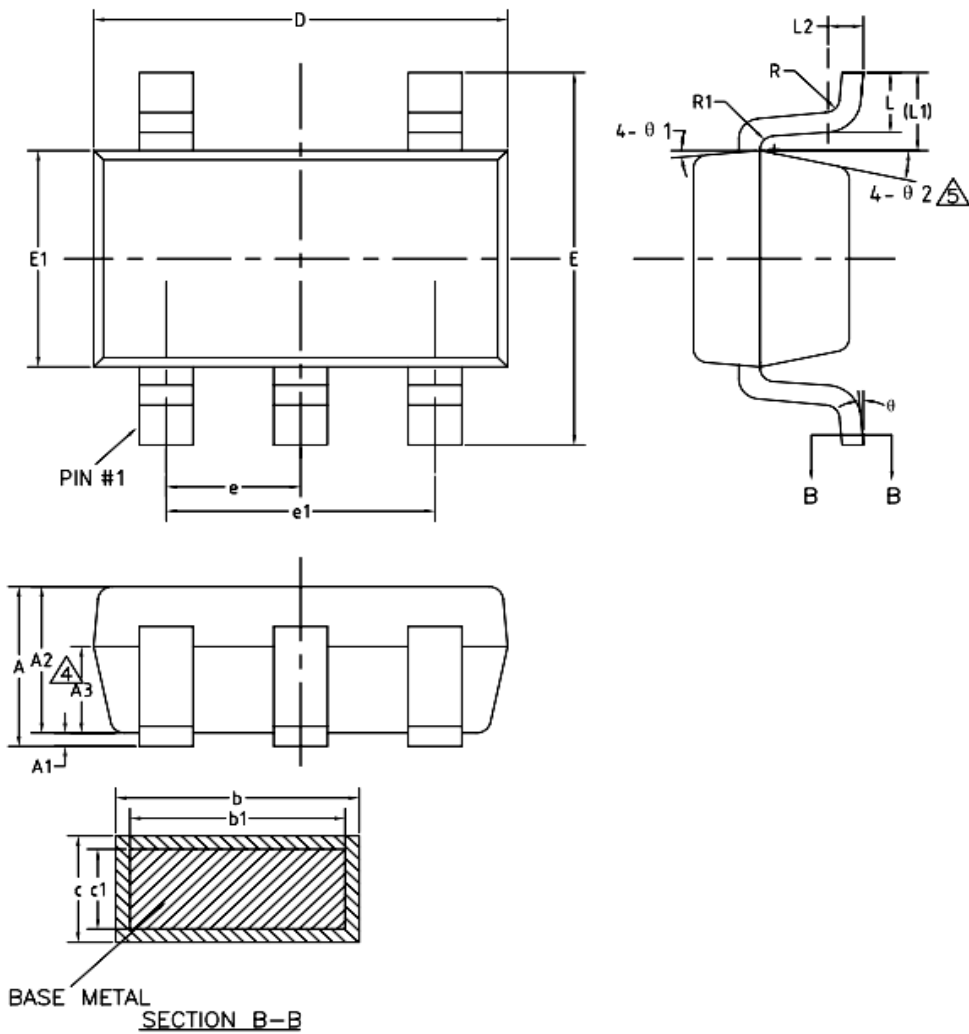

COMMON DIMENSIONS
(UNITS OF MEASURE=MILLIMETER)

SYMBOL	MIN	NOM	MAX
A	—	—	1.25
\triangle A1	0	—	0.15
A2	1.00	1.10	1.20
A3	0.60	0.65	0.70
b	0.36	—	0.50
b1	0.36	0.38	0.45
c	0.14	—	0.20
c1	0.14	0.15	0.16
D	2.826	2.926	3.026
E	2.60	2.80	3.00
E1	1.526	1.626	1.726
\triangle e	0.90	0.95	1.00
\triangle e1	1.80	1.90	2.00
L	0.35	0.45	0.60
L1	0.59REF		
L2	0.25BSC		
R	0.10	—	—
R1	0.10	—	0.25
θ	0°	—	8°
θ_1	3°	5°	7°
\triangle θ_2	6°	—	14°

DFN6(1.0×1.5)

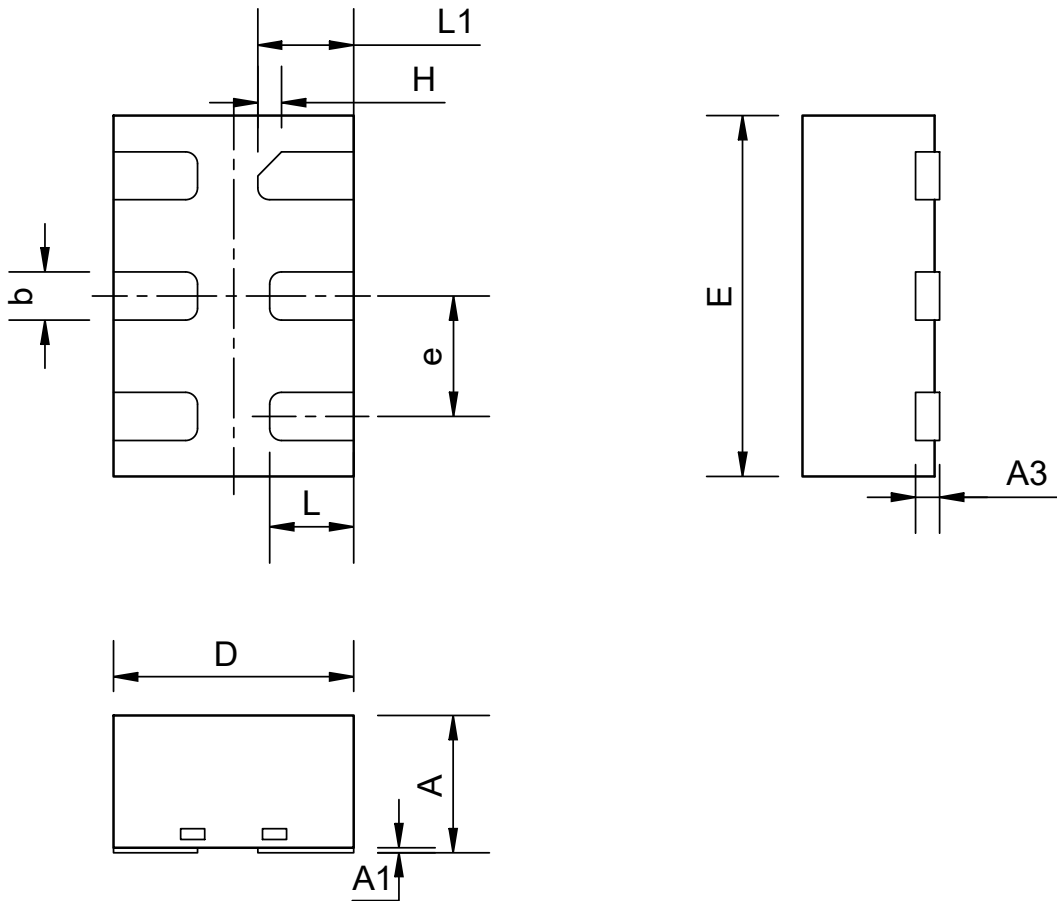

COMMON DIMENSIONS
(UNITS OF MEASURE=MILLIMETER)

SYMBOL	MIN	NOM	MAX
A	0.50	--	0.60
A1	0	0.02	0.05
A3	0.10REF		
b	0.15	0.20	0.25
D	0.90	1.00	1.10
E	1.40	1.50	1.60
e	0.40	0.50	0.60
H	0.10REF		
L	0.30	0.35	0.40
L1	0.35	0.40	0.45

DFN6(1×1)

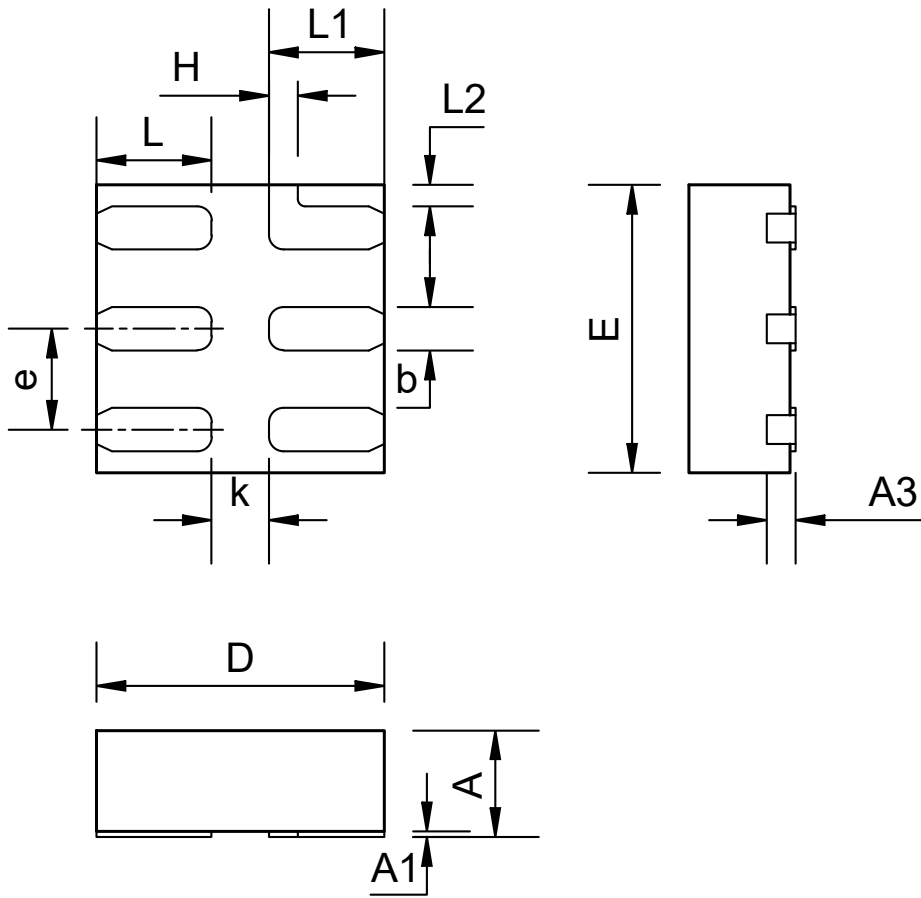

COMMON DIMENSIONS
(UNITS OF MEASURE=MILLIMETER)

SYMBOL	MIN	NOM	MAX
A	0.34	0.37	0.40
A1	0	0.02	0.05
A3	0.10REF		
b	0.10	0.15	0.20
D	0.95	1.00	1.05
E	0.95	1.00	1.05
e	0.30	0.35	0.40
H	0.10REF		
K	0.15	--	--
L	0.35	0.40	0.45
L1	0.35	0.40	0.45
L2	0.075REF		

Ordering information

Order code	Marking code	Package	Baseqty	Deliverymode
UMW SN74AUP1G08DBVR	H08R	SOT23-5	3000	Tape and reel
UMW SN74AUP1G08DCKR	HE5	SC70-5	3000	Tape and reel
UMW SN74AUP1G08DRYR	CE	DFN6	3000	Tape and reel

X-ON Electronics

Largest Supplier of Electrical and Electronic Components

Click to view similar products for [Logic Gates](#) category:

Click to view products by [Youtai](#) manufacturer:

Other Similar products are found below :

[74HC85N](#) [NL17SG32DFT2G](#) [CD4068BE](#) [NL17SG86DFT2G](#) [NLV14001UBDR2G](#) [NLX1G11AMUTCG](#) [NLX1G97MUTCG](#) [74LS38](#)
[74LVC1G08Z-7](#) [74LVC32ADTR2G](#) [CD4025BE](#) [MC74HCT20ADTR2G](#) [NLV17SZ00DFT2G](#) [NLV17SZ126DFT2G](#) [NLV27WZ17DFT2G](#)
[NLV74HC02ADR2G](#) [74HC32S14-13](#) [74LS133](#) [74LVC1G32Z-7](#) [74LVC1G86Z-7](#) [NLV74HC14ADR2G](#) [NLV74HC20ADR2G](#)
[NLVVHC1G09DFT1G](#) [NLX2G86MUTCG](#) [74LVC2G32RA3-7](#) [74LVC2G00HD4-7](#) [NL17SG02P5T5G](#) [74LVC2G86HK3-7](#)
[NLV7SZ97DFT2G](#) [NLVVHC1G14DFT2G](#) [NLX1G99DMUTWG](#) [NLVVHC1G00DFT2G](#) [NLV7SZ57DFT2G](#) [NLV74VHC04DTR2G](#)
[NLV27WZ00USG](#) [NLU1G86CMUTCG](#) [NLU1G08CMUTCG](#) [NL17SZ32P5T5G](#) [NL17SZ00P5T5G](#) [NL17SH02P5T5G](#) [74AUP2G00RA3-7](#)
[NLVVHC1GT00DFT2G](#) [NLV74HC02ADTR2G](#) [NLX1G332CMUTCG](#) [NLVHCT132ADTR2G](#) [NL17SG86P5T5G](#) [NL17SZ05P5T5G](#)
[NLV74VHC00DTR2G](#) [NLVVHC1G02DFT1G](#) [NLV74HC86ADR2G](#)