

Single Non-inverting Schmitt Trigger Buffer

**General Description**

The 74AUP1G17 is a high performance single Non- inverter with Schmitt-Trigger inputs operating from a 0.8V to 3.6V supply. This device is fabricated with advanced CMOS technology to achieve ultra-high speed with high output drive.

**Features**

- Designed for 0.8V to 3.6V V<sub>CC</sub> Operation
- Low static power consumption; I<sub>CC</sub> = 0.7μA (maximum)
- 4mA Balanced Output Sink and Source Capability
- Near Zero Static Supply Current Substantially Reduces System Power Requirements
- These Devices are Pb-Free and are RoHS Compliant
- Tiny SC70-5, SOT23-5 and DFN6(1.0×1.5) Packages

**Pin Configuration**

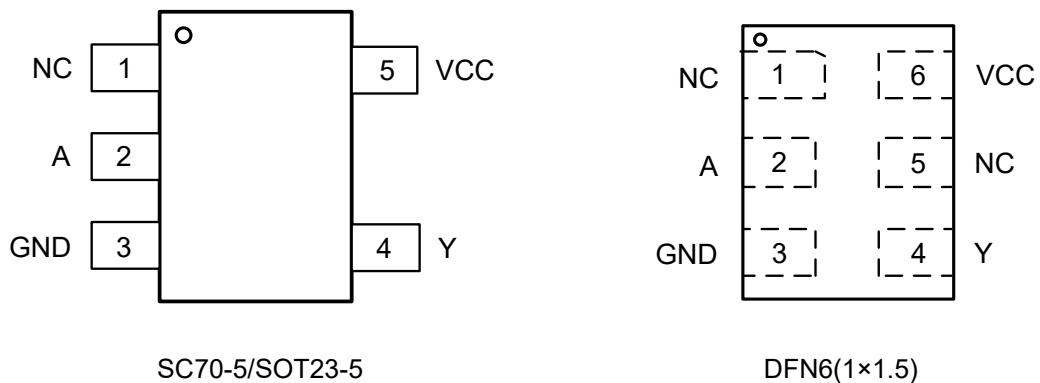

Figure1. Top View

Single Non-inverting Schmitt Trigger Buffer

Pin Function

(SC70-5/ SOT23-5)

Pin No.	Pin Name	Function
1	NC	No connect
2	A	Input
3	GND	Ground
4	Y	Output
5	VCC	Supply Voltage

DFN6

Pin No.	Pin Name	Function
1	NC	No connect
2	A	Input
3	GND	Ground
4	Y	Output
5	NC	No connect
6	VCC	Supply Voltage

Block Diagram

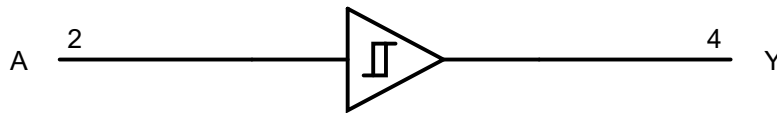

Figure2. Logic Symbol

Functional Description

Function Table

Input A	Output Y
L	L
H	H

**Single Non-inverting Schmitt Trigger Buffer**
**Absolute Maximum Ratings**

Symbol	Parameter		Value	Unit
$V_{CC}$	DC Supply Voltage		-0.5 to 4.6	V
$V_I$	DC Input Voltage		$-0.5 \leq V_I \leq +4.6$	V
$V_O$	DC Output Voltage Output in Higher or Low State <sup>(1)</sup>		-0.5 to 4.6	V
$I_{IK}$	DC Input Diode Current	$V_I < GND$	-50	mA
$I_{OK}$	DC Output Diode Current	$V_O < GND, V_O > V_{CC}$	$\pm 50$	mA
$I_O$	DC Output Sink Current		$\pm 20$	mA
$I_{CC}$	DC Supply Current per Supply Pin		$\pm 50$	mA
$I_{GND}$	DC Ground Current per Supply Pin		$\pm 50$	mA
$T_{STG}$	Storage Temperature Range		-65 to 150	°C
$T_L$	Lead Temperature, Soldering 10 Seconds		260	°C
$T_J$	Max Junction Temperature		150	°C
$V_{ESD}$	ESD Classification	Human Body Model <sup>(2)</sup>	$\pm 4000$	V
		Charged Device Model <sup>(3)</sup>	$\pm 1000$	
$I_{LU}$	Max Latch up Current Above $V_{CC}$ and GND at 125°C <sup>(4)</sup>		$\pm 100$	mA

**Thermal Characteristics**

Symbol	Package	Ratings	Value	Unit
$R_{\theta JA}$	SC70-5	Thermal Characteristics, Thermal Resistance, Junction-to-Air	300	°C/W
	SOT23-5		250	
	DFN6(1×1.5)		440	
$P_D$	SC70-5	Power Dissipation in Still Air at 85°C	215	mW
	SOT23-5		260	
	DFN6(1×1.5)		150	

**Recommended Operating Conditions**

Symbol	Parameter		Min	Max	Unit
$V_{CC}$	DC Supply Voltage Operating		0.8	3.6	V
$V_{IN}$	DC Input Voltage		0	3.6	V
$V_{OUT}$	DC Output Voltage (High or Low State)		0	3.6	V
$T_A$	Operating Temperature Range		-40	85	°C
$t_r, t_f$	Input Rise and Fall Time	$V_{CC} = 0.8V$ to 3.6V	0	20	ns/V

Functional operation above the stresses listed in the Recommended Operating Ranges is not implied.

**Single Non-inverting Schmitt Trigger Buffer**
**Electrical Characteristics**
**DC Electrical Characteristics**

Symbol	Parameter	Condition	V <sub>CC</sub> (V)	T <sub>A</sub> = 25°C			-40°C ≤ T <sub>A</sub> ≤ 85°C		Unit
				Min	Typ	Max	Min	Max	
V <sub>IH</sub>	High-Level Input Voltage		0.8	0.75V <sub>CC</sub>			0.75V <sub>CC</sub>		V
			0.9 to 1.95	0.7V <sub>CC</sub>			0.7V <sub>CC</sub>		
			2.3 to 2.7	1.6			1.6		
			3.0 to 3.6	2.0			2.0		
V <sub>IL</sub>	Low-Level Input Voltage		0.8			0.25V <sub>CC</sub>		0.25V <sub>CC</sub>	V
			0.9 to 1.95			0.3V <sub>CC</sub>		0.3V <sub>CC</sub>	
			2.3 to 2.7			0.7		0.7	
			3.0 to 3.6			0.9		0.9	
V <sub>OH</sub>	High-Level Output Voltage	I <sub>OH</sub> = -20uA	0.8 to 3.6	V <sub>CC</sub> -0.1			V <sub>CC</sub> -0.1		V
		I <sub>OH</sub> = -1.1mA	1.1	0.82	1.02		0.77		
		I <sub>OH</sub> = -1.7mA	1.4	1.11	1.32		1.03		
		I <sub>OH</sub> = -1.9mA	1.65	1.32	1.58		1.30		
		I <sub>OH</sub> = -2.3mA	2.3	2.05	2.24		1.97		
		I <sub>OH</sub> = -3.1mA		1.9	2.22		1.85		
		I <sub>OH</sub> = -2.7mA	3.0	2.72	2.95		2.67		
		I <sub>OH</sub> = -4.0mA		2.6	2.92		2.55		
V <sub>OL</sub>	Low-Level Output Voltage	I <sub>OL</sub> = 20uA	0.8 to 3.6			0.1		0.1	V
		I <sub>OL</sub> = 1.1mA	1.1		0.11	0.33		0.33	
		I <sub>OL</sub> = 1.7mA	1.4		0.12	0.31		0.37	
		I <sub>OL</sub> = 1.9mA	1.65		0.11	0.31		0.35	
		I <sub>OL</sub> = 2.3mA	2.3		0.14	0.31		0.33	
		I <sub>OL</sub> = 3.1mA			0.19	0.44		0.45	
		I <sub>OL</sub> = 2.7mA	3.0		0.11	0.31		0.33	
		I <sub>OL</sub> = 4.0mA			0.16	0.44		0.45	
I <sub>IN</sub>	Input Leakage Current	V <sub>IN</sub> = V <sub>CC</sub> or GND	0 to 3.6			±0.1		±0.2	uA
I <sub>OFF</sub>	Power Off Leakage Current	V <sub>IN</sub> = 3.6 V or V <sub>OUT</sub> = 3.6 V	0			±0.2		±0.5	uA
I <sub>CC</sub>	Quiescent Supply Current	V <sub>IN</sub> = 3.6V or GND	3.6			±0.2		±0.7	uA

Product parametric performance is indicated in the Electrical Characteristics for the listed test conditions, unless otherwise noted. Product performance may not be indicated by the Electrical Characteristics if operated under different conditions.

**Single Non-inverting Schmitt Trigger Buffer**
**AC Electrical Characteristics**
 $t_r = t_f = 2.5\text{ns}$ 

Symbol	Parameter	Condition	V <sub>CC</sub> (V)	T <sub>A</sub> = 25°C			-40°C ≤ T <sub>A</sub> ≤ 85°C		Unit
				Min	Typ	Max	Min	Max	
t <sub>PLH</sub> t <sub>PHL</sub>	Propagation Delay (Figure3 And 4)	C <sub>L</sub> = 5 pF <sup>(5)</sup>	0.8	13.2	29	90.1	11.9	220	ns
			1.2	5.0	7.6	14.3	4.6	14.4	
			1.5	3.4	4.8	8.9	3	9.6	
			1.8	2.7	3.6	6.9	2.3	7.6	
			2.5	1.9	2.4	5.1	1.6	5.6	
			3.3	1.5	1.9	4.4	1.3	4.8	
		C <sub>L</sub> = 10 pF <sup>(5)</sup>	0.8	14.3	31.3	97.9	12.8	239	ns
			1.2	5.4	8.3	15.3	5.0	15.3	
			1.5	3.7	5.2	9.5	3.2	10.2	
			1.8	2.9	3.9	7.4	2.5	8.1	
			2.5	2.0	2.6	5.4	1.7	6.0	
			3.3	1.6	2.0	4.6	1.3	5.1	
		C <sub>L</sub> = 15 pF <sup>(5)</sup>	0.8	15.3	32.5	106	13.8	259	ns
			1.2	5.8	8.9	16.3	5.3	16.3	
			1.5	4.0	5.6	10.1	3.5	10.9	
			1.8	3.1	4.2	7.8	2.6	8.6	
			2.5	2.1	2.8	5.8	1.8	6.4	
			3.3	1.7	2.2	4.9	1.4	5.4	
		C <sub>L</sub> = 30 pF <sup>(5)</sup>	0.8	18.3	37.5	130	16.6	323	ns
			1.2	7.0	10.7	19.3	6.4	19.3	
			1.5	4.8	6.9	12.0	4.2	12.9	
			1.8	3.7	5.1	9.2	3.2	10.2	
			2.5	2.6	3.5	6.7	2.2	7.5	
			3.3	2.0	2.2	5.6	1.7	6.3	

**Note5.** C<sub>L</sub> includes probe and jig capacitance.

Capacitance Characteristics

Symbol	Parameter	Condition	Typical	Unit	
C <sub>IN</sub>	Input Capacitance	V <sub>CC</sub> = 3.6V, V <sub>I</sub> = 0 V or V <sub>CC</sub>	2	pF	
C <sub>O</sub>	output capacitance	V <sub>CC</sub> = 0V, V <sub>OUT</sub> = GND	3	pF	
C <sub>PD</sub>	Power Dissipation Capacitance <sup>(6)</sup>	1 MHz, V <sub>I</sub> = 0 V to V <sub>CC</sub>	V <sub>CC</sub> = 0.8V	7.6	pF
			V <sub>CC</sub> = 1.2V	8.1	
			V <sub>CC</sub> = 1.5V	8.5	
			V <sub>CC</sub> = 1.8V	8.6	
			V <sub>CC</sub> = 2.5V	9.0	
			V <sub>CC</sub> = 3.3 V	9.6	

**Note6.** C<sub>PD</sub> is defined as the value of the internal equivalent capacitance which is calculated from the operating current consumption without load. Average operating current can be obtained by the equation: I<sub>CC(OPR)</sub>=C<sub>PD</sub>×V<sub>CC</sub>×fin+I<sub>CC</sub>×C<sub>PD</sub> is used to determine the no-load dynamic power consumption; P<sub>D</sub>=C<sub>PD</sub>×V<sub>CC</sub><sup>2</sup> ×fin+I<sub>CC</sub>×V<sub>CC</sub>×Fig.

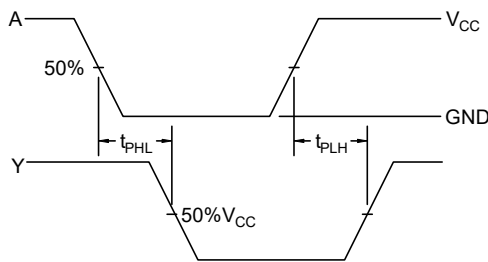

Figure 3. Switching Waveform

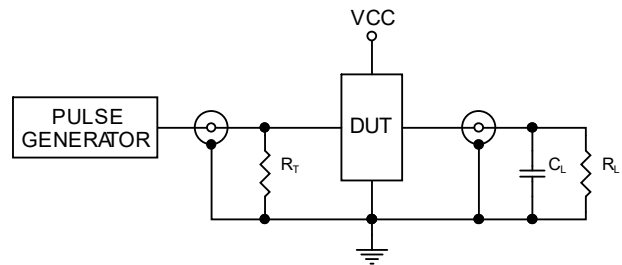
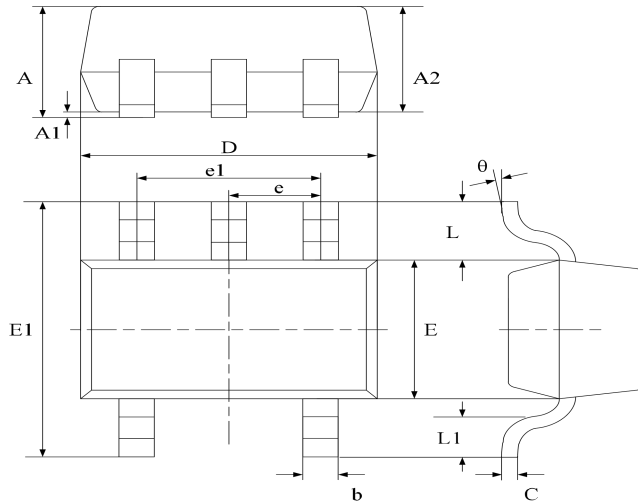

Figure4. Test Circuit

Package Dimension

SC70-5 (SOT353)



Symbol	Dimensions In Millimeters		Dimensions In Inches	
	Min	Max	Min	Max
A	0.800	1.100	0.035	0.043
A1	0.000	0.100	0.000	0.004
A2	0.800	0.900	0.035	0.039
b	0.150	0.350	0.006	0.014
C	0.080	0.150	0.003	0.006
D	1.8500	2.150	0.079	0.087
E	1.100	1.400	0.045	0.053
E1	1.950	2.200	0.085	0.096
e	0.850 typ.		0.026 typ.	
e1	1.200	1.400	0.047	0.055
L	0.42 ref.		0.021 ref.	
L1	0.260	0.460	0.010	0.018
θ	0°	8°	0°	8°

SOT23-5

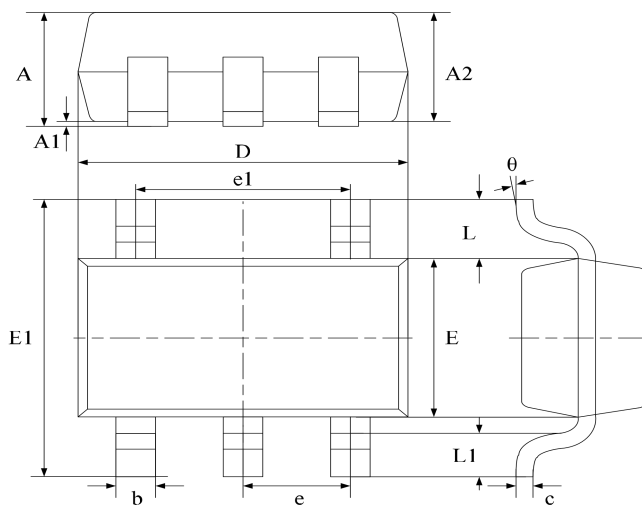

Symbol	Dimensions In Millimeters		Dimensions In Inches	
	Min	Max	Min	Max
A	1.040	1.350	0.042	0.055
A1	0.040	0.150	0.002	0.006
A2	1.000	1.200	0.041	0.049
b	0.380	0.480	0.015	0.020
c	0.110	0.210	0.004	0.009
D	2.720	3.120	0.111	0.127
E	1.400	1.800	0.057	0.073
E1	2.600	3.000	0.106	0.122
e	0.950 typ.		0.037 typ.	
e1	1.900 typ.		0.078 typ.	
L	0.700 ref.		0.028 ref.	
L1	0.300	0.600	0.012	0.024
θ	0°	8°	0°	8°

DFN6(1.0×1.5)

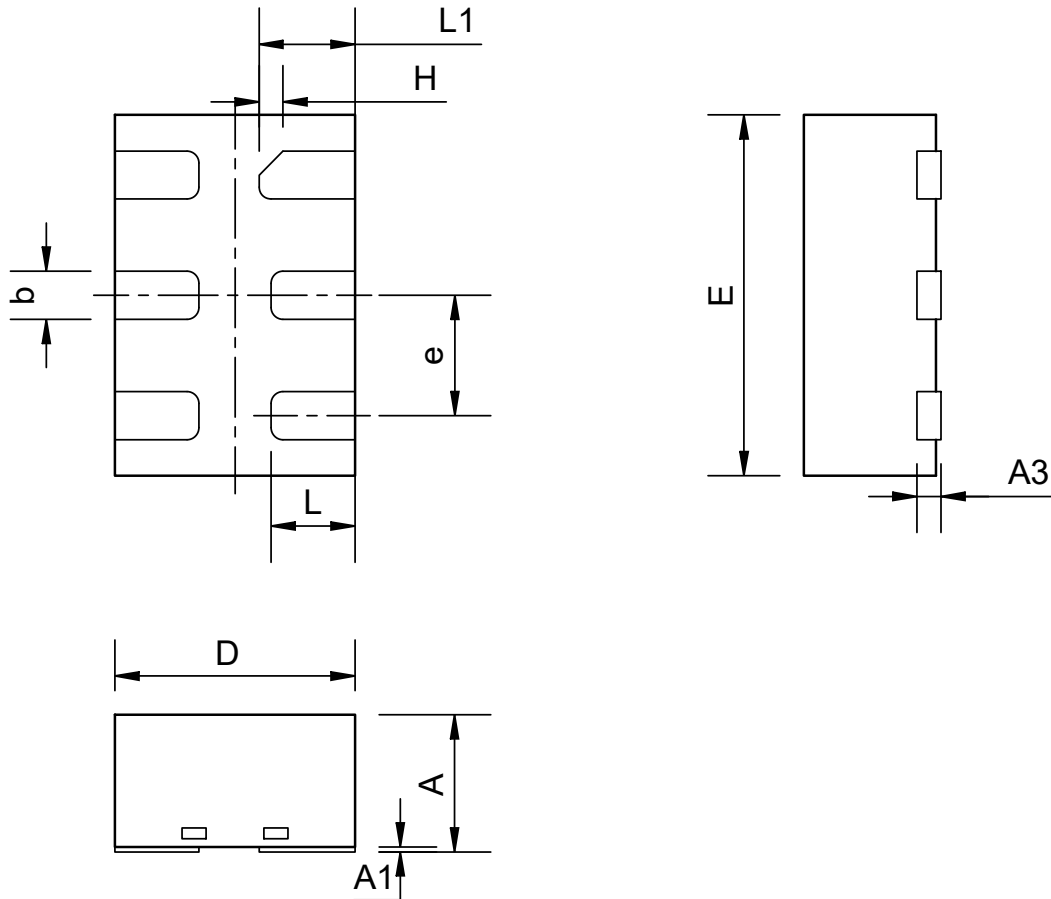

COMMON DIMENSIONS  
(UNITS OF MEASURE=MILLIMETER)

SYMBOL	MIN	NOM	MAX
A	0.50	--	0.60
A1	0	0.02	0.05
A3	0.10REF		
b	0.15	0.20	0.25
D	0.90	1.00	1.10
E	1.40	1.50	1.60
e	0.40	0.50	0.60
H	0.10REF		
L	0.30	0.35	0.40
L1	0.35	0.40	0.45



**Ordering information**

Order code	Package	Baseqty	Deliverymode	Marking
UMW SN74AUP1G17DCKR	SC70-5	3000	Tape and reel	H7F U
UMW SN74AUP1G17DBVR	SOT23-5	3000	Tape and reel	H17F U
UMW SN74AUP1G17DRYR	DFN6	5000	Tape and reel	H7 U

## X-ON Electronics

Largest Supplier of Electrical and Electronic Components

*Click to view similar products for [Buffers & Line Drivers](#) category:*

*Click to view products by [Youtai](#) manufacturer:*

Other Similar products are found below :

[LXV200-024SW](#) [74AUP2G34FW3-7](#) [HEF4043BP](#) [NL17SG125DFT2G](#) [NLU1GT126CMUTCG](#) [CD4041UBE](#) [54FCT240CTDB](#)  
[74HCT540N](#) [DS14C88N](#) [070519XB](#) [NL17SZ07P5T5G](#) [74LVC2G17FW4-7](#) [CD4502BE](#) [5962-8982101PA](#) [61446R00](#) [NL17SH17P5T5G](#)  
[NLV37WZ17USG](#) [74HCT126T14-13](#) [74VHC9126FT\(BJ\)](#) [RHRXH162244K1](#) [74AUP1G34FW5-7](#) [74AUP1G07FW5-7](#) [74LVC1G126FW4-7](#)  
[74LVC2G126RA3-7](#) [74LVCE1G125FZ4-7](#) [74AUP1G126FW5-7](#) [54FCT240TLB](#) [NLX3G16DMUTCG](#) [NLX2G06AMUTCG](#)  
[LE87100NQCT](#) [LE87285NQC](#) [LE87290YQC](#) [LE87290YQCT](#) [74AUP1G125FW5-7](#) [NLU2G16CMUTCG](#) [MC74LCX244MN2TWG](#)  
[NL17SG17P5T5G](#) [NLV74HC125ADR2G](#) [NLVHCT245ADTR2G](#) [NLVVHC1G126DFT2G](#) [EL5623IRZ](#) [ISL15102AIRZ-T13](#) [ISL1539IRZ-](#)  
[T13](#) [MC100EP17MNG](#) [MC74HCT365ADR2G](#) [MC74LCX244ADTR2G](#) [NL27WZ126US](#) [NL37WZ16US](#) [NLU1G07MUTCG](#)  
[NLU2G07MUTCG](#)