

General Description

The SN74AUP2G14 is a high performance dual inverter with Schmitt-Trigger inputs operating from a 0.8V to 3.6V supply. This device is fabricated with advanced CMOS technology to achieve ultra-high speed with high output drive.

Features

- Designed for 0.8V to 3.6V V_{CC} Operation
- Low static power consumption; I_{CC} = 0.7μA (maximum)
- 4mA Balanced Output Sink and Source Capability
- Near Zero Static Supply Current Substantially Reduces System Power Requirements
- These Devices are Pb-Free and are RoHS Compliant

Pin Configuration

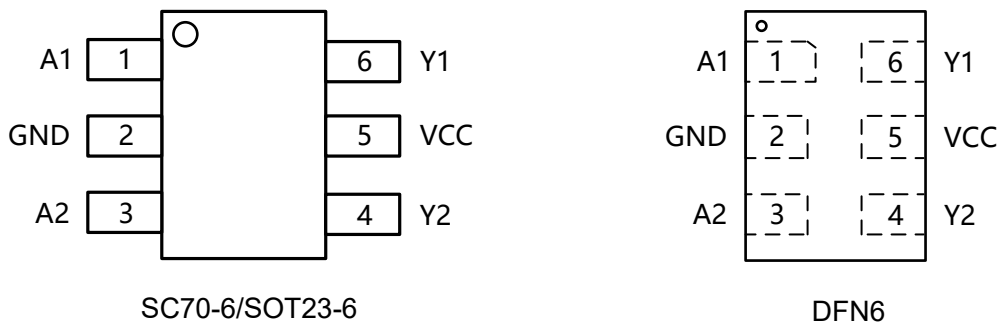

Figure1. Top View

Pin Function

SC70-6/ SOT23-6

Pin No.	Function
1	A1
2	GND
3	A2
4	Y2
5	VCC
6	Y1

DFN6

Pin No.	Function
1	A1
2	GND
3	A2
4	Y2
5	VCC
6	Y1

Block Diagram

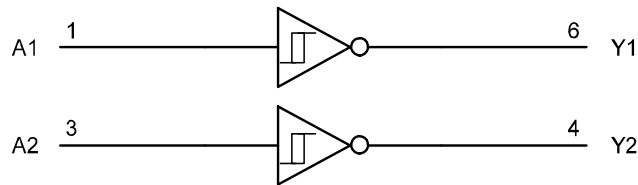

Figure2.

Functional Description

Function Table

A Input	Y Output
L	H
H	L

Absolute Maximum Ratings

Symbol	Parameter		Value	Unit
V_{CC}	DC Supply Voltage		-0.5 to 4.6	V
V_I	DC Input Voltage		$-0.5 \leq V_I \leq +4.6$	V
V_O	DC Output Voltage Output in Higher or Low State ⁽¹⁾		-0.5 to 4.6	V
I_{IK}	DC Input Diode Current	$V_I < GND$	-50	mA
I_{OK}	DC Output Diode Current	$V_O < GND, V_O > V_{CC}$	± 50	mA
I_O	DC Output Sink Current		± 20	mA
I_{CC}	DC Supply Current per Supply Pin		± 50	mA
I_{GND}	DC Ground Current per Supply Pin		± 50	mA
T_{STG}	Storage Temperature Range		-65 to 150	°C
T_L	Lead Temperature, 1 mm from Case for 10 Seconds		260	°C
T_J	Junction Temperature Under Bias		150	°C
P_D	Power Dissipation in Still Air at 85°C		200	mW
V_{ESD}	ESD Classification	Human Body Model ⁽²⁾	± 4000	V
		Machine Model ⁽³⁾	± 200	
		Charged Device Model ⁽⁴⁾	± 1000	
I_{LU}	Latchup Current Above V_{CC} and GND at 125°C ⁽⁵⁾		± 100	mA

Recommended Operating Conditions

Symbol	Parameter		Min	Max	Unit
V_{CC}	DC Supply Voltage Operating		0.8	3.6	V
V_{IN}	DC Input Voltage		0	3.6	V
V_{OUT}	DC Output Voltage (High or Low State)		0	3.6	V
T_A	Operating Temperature Range		-40	85	°C
t_r, t_f	Input Rise and Fall Time	V			

Functional operation above the stresses listed in the Recommended Operating Ranges is not implied.

Electrical Characteristics
DC Electrical Characteristics

Symbol	Parameter	Condition	V _{CC} (V)	T _A = 25°C			-40°C ≤ T _A ≤ 85°C		Unit
				Min	Typ	Max	Min	Max	
V _{IH}	High-Level Input Voltage		0.8V	0.75V _{CC}			0.75V _{CC}		V
			0.9 to 1.95V	0.7V _{CC}			0.7V _{CC}		
			2.3 to 2.7V	1.6			1.6		
			3.0 to 3.6V	2.0			2.0		
V _{IL}	Low-Level Input Voltage		0.8V			0.25V _{CC}		0.25V _{CC}	V
			0.9 to 1.95V			0.3V _{CC}		0.3V _{CC}	
			2.3 to 2.7V			0.7		0.7	
			3.0 to 3.6V			0.9		0.9	
V _{OH}	High-Level Output Voltage	I _{OH} = -20μA	0.8 to 3.6V	V _{CC} -0.1			V _{CC} -0.1		V
		I _{OH} = -1.1mA	1.1	0.82	1.02		0.77		
		I _{OH} = -1.7mA	1.4	1.11	1.32		1.03		
		I _{OH} = -1.9mA	1.65	1.32	1.58		1.30		
		I _{OH} = -2.3mA	2.3	2.05	2.24		1.97		
		I _{OH} = -3.1mA		1.9	2.22		1.85		
		I _{OH} = -2.7mA	3.0	2.72	2.95		2.67		
		I _{OH} = -4.0mA		2.6	2.92		2.55		
V _{OL}	Low-Level Output Voltage	I _{OL} = 20μA	0.8 to 3.6V			0.1		0.1	V
		I _{OL} = 1.1mA	1.1		0.11	0.33		0.33	
		I _{OL} = 1.7mA	1.4		0.12	0.31		0.37	
		I _{OL} = 1.9mA	1.65		0.11	0.31		0.35	
		I _{OL} = 2.3mA	2.3		0.14	0.31		0.33	
		I _{OL} = 3.1mA			0.19	0.44		0.45	
		I _{OL} = 2.7mA	3.0		0.11	0.31		0.33	
		I _{OL} = 4.0mA			0.16	0.44		0.45	
I _{IN}	Input Leakage Current	V _{IN} = V _{CC} or GND	0 to 3.6V			±0.1		±0.2	μA
I _{OFF}	Power Off Leakage Current	V _{IN} = 3.6 V or V _{OUT} = 3.6 V	0			±0.2		±0.5	μA
I _{CC}	Quiescent Supply Current	V _{IN} = 3.6V or GND	3.6			±0.2		±0.7	μA

AC Electrical Characteristics

$t_r = t_f = 2.5\text{ns}$

Symbol	Parameter	Condition	V _{CC} (V)	T _A = 25°C			-40°C ≤ T _A ≤ 85°C		Unit
				Min	Typ	Max	Min	Max	
t _{PLZ} t _{PZL}	Propagation Delay (Figure3 And 4)	C _L = 5 pF ⁽⁶⁾	0.8	13.2	29	90.1	11.9	220	ns
			1.2	5.0	7.6	14.3	4.6	14.4	
			1.5	3.4	4.8	8.9	3	9.6	
			1.8	2.7	3.6	6.9	2.3	7.6	
			2.5	1.9	2.4	5.1	1.6	5.6	
			3.3	1.5	1.9	4.4	1.3	4.8	
		C _L = 10 pF ⁽⁶⁾	0.8	14.3	31.3	97.9	12.8	239	ns
			1.2	5.4	8.3	15.3	5.0	15.3	
			1.5	3.7	5.2	9.5	3.2	10.2	
			1.8	2.9	3.9	7.4	2.5	8.1	
			2.5	2.0	2.6	5.4	1.7	6.0	
			3.3	1.6	2.0	4.6	1.3	5.1	
		C _L = 15 pF ⁽⁶⁾	0.8	15.3	32.5	106	13.8	259	ns
			1.2	5.8	8.9	16.3	5.3	16.3	
			1.5	4.0	5.6	10.1	3.5	10.9	
			1.8	3.1	4.2	7.8	2.6	8.6	
			2.5	2.1	2.8	5.8	1.8	6.4	
			3.3	1.7	2.2	4.9	1.4	5.4	
		C _L = 30 pF ⁽⁶⁾	0.8	18.3	37.5	130	16.6	323	ns
			1.2	7.0	10.7	19.3	6.4	19.3	
			1.5	4.8	6.9	12.0	4.2	12.9	
			1.8	3.7	5.1	9.2	3.2	10.2	
			2.5	2.6	3.5	6.7	2.2	7.5	
			3.3	2.0	2.2	5.6	1.7	6.3	

Note6. C_L includes probe and jig capacitance.

Capacitance Characteristics

Symbol	Parameter	Condition	Typical	Unit	
C _{IN}	Input Capacitance	V _{CC} = 3.6V, V _I = 0 V or V _{CC}	2	pF	
C _O	output capacitance	V _{CC} = 0V, V _{OUT} = GND	3	pF	
C _{PD}	Power Dissipation Capacitance ⁽⁷⁾	1 MHz, V _I = 0 V to V _{CC}	V _{CC} = 0.8V	7.6	pF
			V _{CC} = 1.2V	8.1	
			V _{CC} = 1.5V	8.5	
			V _{CC} = 1.8V	8.6	
			V _{CC} = 2.5V	9.0	
			V _{CC} = 3.3 V	9.6	

Note7. C_{PD} is defined as the value of the internal equivalent capacitance which is calculated from the operating current consumption without load. Average operating current can be obtained by the equation: I_{CC(OPR)}=C_{PD}×V_{CC}×fin+I_{CC}×C_{PD} is used to determine the no-load dynamic power consumption; P_D=C_{PD}×V_{CC}² ×fin+I_{CC}×V_{CC}×Fig.

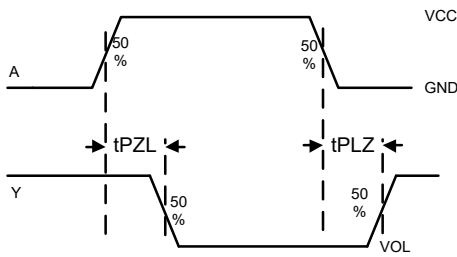

Figure 3. Switching Waveform

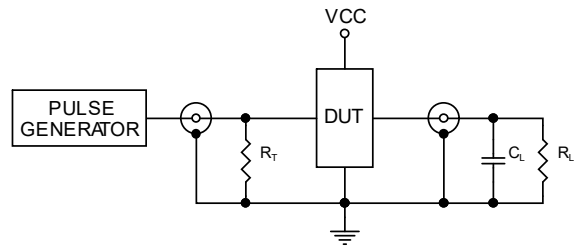
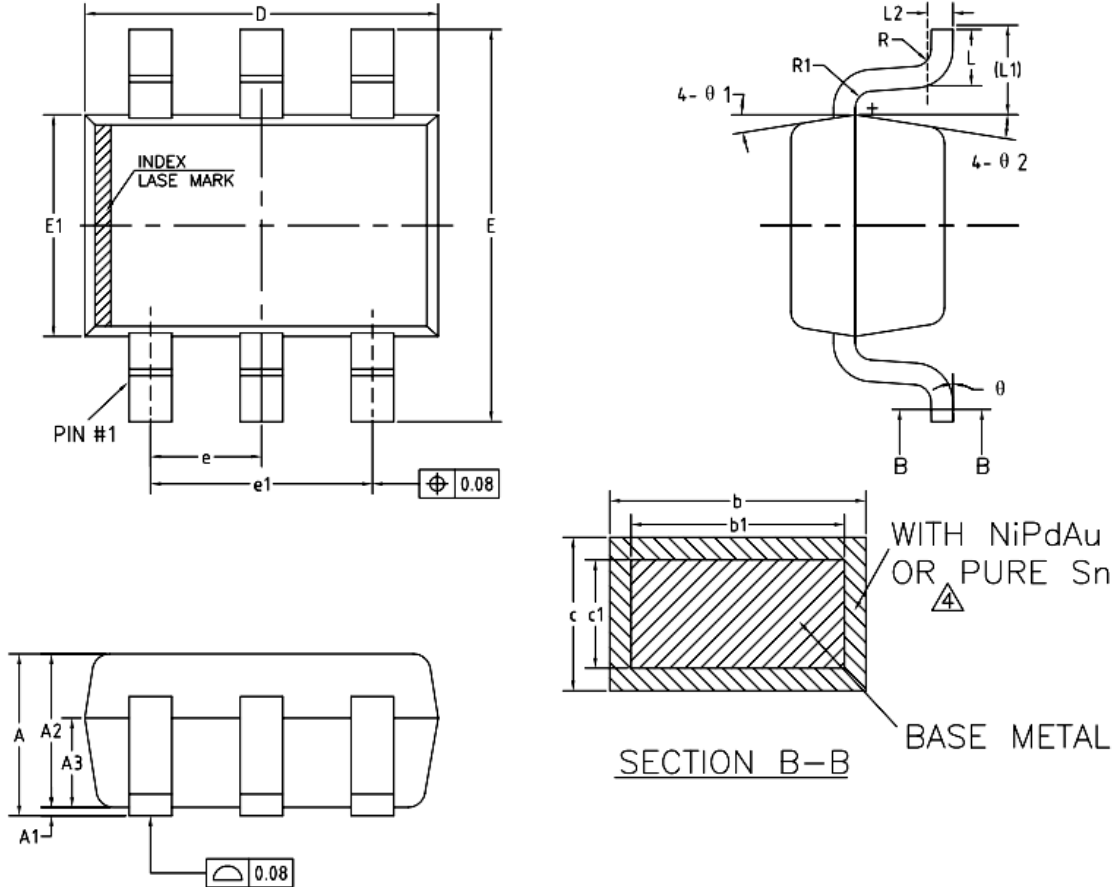

Figure4. Test Circuit

Package Dimension

SC70-6



COMMON DIMENSIONS
(UNITS OF MEASURE=MILLIMETER)

SYMBOL	MIN	NOM	MAX
A	0.85	—	1.05
A1	0	—	0.10
A2	0.80	0.90	1.00
A3	0.47	0.52	0.57
b	NiPdAu 0.22 PURE Sn 0.23	—	0.29 0.33
b1	0.22	0.25	0.28
c	NiPdAu 0.115 PURE Sn 0.12	—	0.15 0.18
c1	0.115	0.13	0.14
D	2.02	2.07	2.12
E	2.20	2.30	2.40
E1	1.25	1.30	1.35
e	0.60	0.65	0.70
e1	1.20	1.30	1.40
L	0.28	0.33	0.38
L1	0.50REF		
L2	0.15BSC		
R	0.10	—	—
R1	0.10	—	0.25
θ	0°	—	8°
θ 1	6°	9°	12°
θ 2	6°	9°	12°

SOT23-6

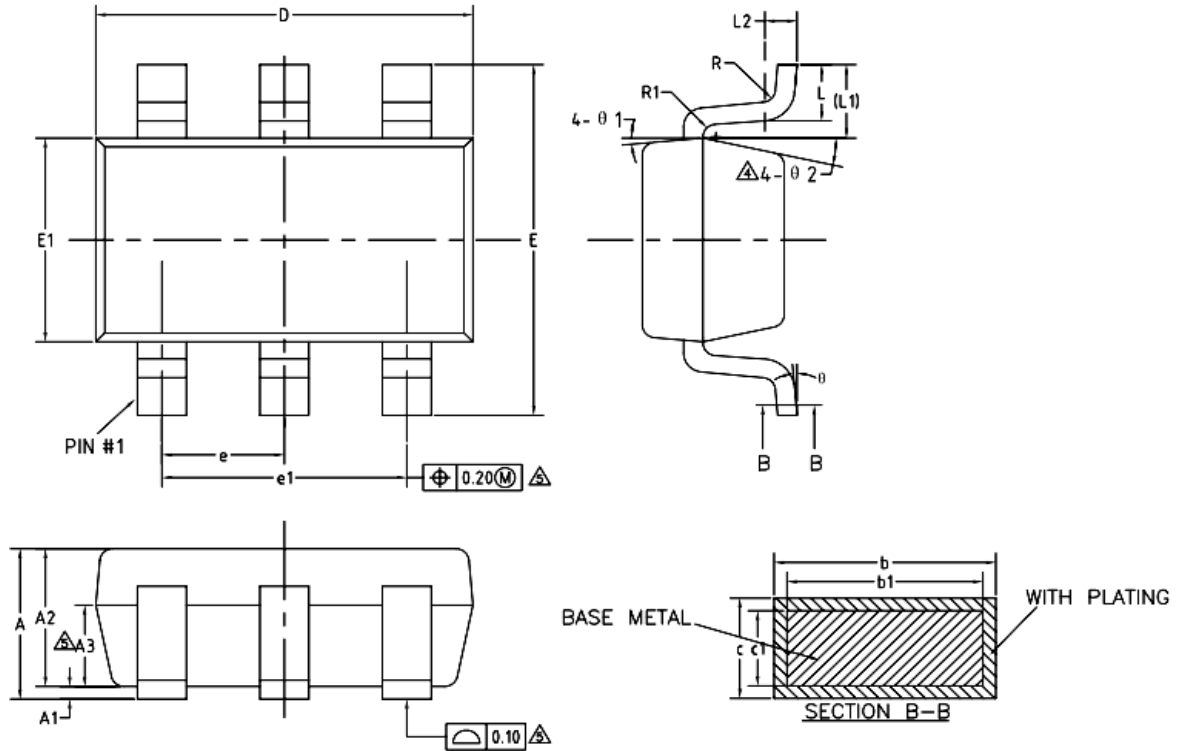

COMMON DIMENSIONS
(UNITS OF MEASURE=MILLIMETER)

SYMBOL	MIN	NOM	MAX
A	—	—	1.25
A1	0	—	0.15
A2	1.00	1.10	1.20
A3	0.60	0.65	0.70
b	0.36	—	0.50
b1	0.36	0.38	0.45
c	0.14	—	0.20
c1	0.14	0.15	0.16
D	2.826	2.926	3.026
E	2.60	2.80	3.00
E1	1.526	1.626	1.726
Δ e	0.90	0.95	1.00
Δ e1	1.80	1.90	2.00
L	0.35	0.45	0.60
L1	0.59REF		
L2	0.25BSC		
Δ R	0.10	—	—
Δ R1	0.10	—	0.20
θ	0°	—	8°
θ 1	3°	5°	7°
Δ θ 2	6°	—	14°

DFN6(1.0×1.5)

Ordering information

Order code	Package	Baseqty	Deliverymode	Marking code
UMW SN74AUP2G14DBVR	SOT23-6	3000	Tape and reel	H65R U
UMW SN74AUP2G14DCKR	SC70- 6	3000	Tape and reel	H6F U
UMW SN74AUP2G14DRYR	DFN6	5000	Tape and reel	H6 U

X-ON Electronics

Largest Supplier of Electrical and Electronic Components

Click to view similar products for [Inverters](#) category:

Click to view products by [Youtai](#) manufacturer:

Other Similar products are found below :

[E5-652Z](#) [NLX2G04BMX1TCG](#) [CD4009UBE](#) [TC4584BFN](#) [NL17SG14AMUTCG](#) [NLU2GU04BMX1TCG](#) [NLV17SZ14DFT2G](#)
[NLV74HC04ADTR2G](#) [NLU1G04AMUTCG](#) [NLX2G04CMUTCG](#) [NLX2G04AMUTCG](#) [NLV27WZ04DFT1G](#) [NLU1G04CMUTCG](#)
[NL17SZU04P5T5G](#) [74LVC06ADTR2G](#) [74LVC04ADR2G](#) [NLV37WZ04USG](#) [NLX3G14FMUTCG](#) [NL17SZ04P5T5G](#) [NL17SG14P5T5G](#)
[NLV27WZU04DFT2G](#) [NLV17SG14DFT2G](#) [NLVHC1G04DFT2G](#) [MC14069UBD](#) [NLU3G14CMX1TCG](#) [NLX2G14BMX1TCG](#)
[NLX2GU04AMX1TCG](#) [74HCT04DT](#) [74HCT14DT](#) [74LCX14FT\(AJ\)](#) [EG8015](#) [GN14D](#) [GN4069](#) [74HC04DM/TR](#) [HG74HC04M/TR](#)
[CD40106DM/TR](#) [CD4007BE](#) [74HC14DN](#) [74HC14DM/TR](#) [CD4069UBE](#) [74HC125M/TR](#) [CD4069UBMT/TR](#) [HG74HC04MT/TR](#)
[74HC14DMT/TR](#) [74HC04DN](#) [HT74HC04ARZ](#) [HT40106ARZ](#) [74HC14-HXY](#) [IW4069UBN](#) [RS1GT04XC5](#)