

**General Description**

The SN74LVC1G17 is a single Non-inverting Schmitt Trigger Buffer in three tiny footprint packages.

**Features**

- Tiny SC70-5, SOT23-5 and DFN6-1.0mm\*1.5mm Packages
- Source/Sink 24mA at 3.0V
- Chip Complexity: FETs = 20
- Designed for 1.65V to 5.5V V<sub>CC</sub> Operation
- These Devices are Pb-Free, Halogen Free/BFR Free and are RoHS Compliant

**Pin Configuration**

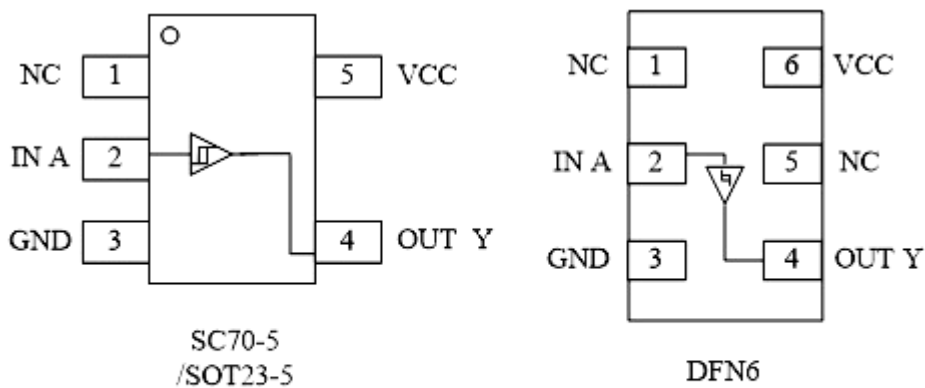

**Figure1. Pinouts (Top View)**

**Pin Function**

(SC70-5/ SOT23-5)

PIN	FUNCTION
1	NC
2	IN A
3	GND
4	VCC
5	OUT

**DFN6**

PIN	FUNCTION
1	NC
2	IN A
3	GND
4	VCC
5	NC
6	OUT

**Block Diagram**

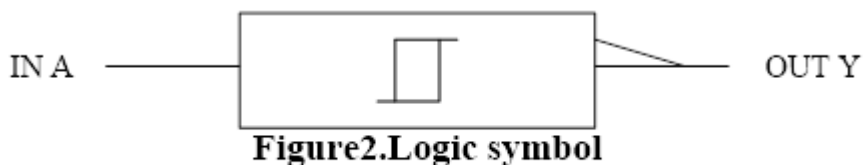

**Functional Description**

**Function Table**

Input	Output
A	Y
L	L
H	H

**Absolute Maximum Ratings**

Symbol	Parameter	Value	Unit
V <sub>CC</sub>	DC Supply Voltage	-0.5 to 7.0	V
V <sub>I</sub>	DC Input Voltage	-0.5 ≤ V <sub>I</sub> ≤ +7.0	V
V <sub>O</sub>	DC Output Voltage Output in Higher or Low State (Note 1)	-0.5 to V <sub>CC</sub> + 0.5	V
I <sub>IK</sub>	DC Input Diode Current V <sub>I</sub> < GND	-50	mA
I <sub>OK</sub>	DC Output Diode Current V <sub>O</sub> < GND, V <sub>O</sub> > V <sub>CC</sub>	±50	mA
I <sub>O</sub>	DC Output Sink Current	±50	mA
I <sub>CC</sub>	DC Supply Current per Supply Pin	±100	mA
I <sub>GND</sub>	DC Ground Current per Supply Pin	±100	mA
T <sub>STG</sub>	Storage Temperature Range	-65 to 150	°C
T <sub>L</sub>	Lead Temperature, 1 mm from Case for 10 Seconds	260	°C
T <sub>J</sub>	Junction Temperature Under Bias	150	°C
θ <sub>JA</sub>	Thermal Resistance SC70-5 (Note 1)	435	°C/W
	SOT23-5	300	
	DFN6	450	
P <sub>D</sub>	Power Dissipation in Still Air at 85°C SC70-5	150	mW
	SOT23-5	200	
	DFN6	130	
MSL	Moisture Sensitivity	Level 1	
F <sub>R</sub>	Flammability Rating Oxygen Index:28 to 34	UL94V-0@0.12in	
ESD	ESD Classification Human Body Model (Note 2)	2000	V
	Machine Model (Note 3)	200	
	Charged Device Model (Note4)	N/A	
I <sub>Latchup</sub>	Latchup Performance Above V <sub>CC</sub> and Below GND at 125°C (Note 5)	±100	mA

Stresses exceeding Maximum Ratings may damage the device. Maximum Ratings are stress ratings only.

Functional operation above the Recommended Operating Conditions is not implied. Extended exposure to stresses above the Recommended Operating Conditions may affect device reliability.

1. Measured with minimum pad spacing on an FR4 board, using 10 mm-by-1 inch, 2-ounce copper trace with no air flow.

2. Tested to EIA/JESD22-A114-A, rated to EIA/JESD22-A114-B.

3. Tested to EIA/JESD22-A115-A, rated to EIA/JESD22-A115-A.

4. Tested to JESD22-C101-A.

5. Tested to EIA/JESD78.

**Recommended Operating Conditions**

Symbol	Parameter	Min	Max	Unit
V <sub>CC</sub>	DC Supply Voltage Operating	1.65	5.5	V
	Date Retention	1.5	5.5	
V <sub>IN</sub>	DC Input Voltage	0	5.5	V
V <sub>OUT</sub>	DC Output Voltage (High or Low State) (SOT-353/ SOT-23-5L/SOT-553 Packages)	0	5.5	V
T <sub>A</sub>	Operating Temperature Range	-55	125	°C
t <sub>r</sub> ,t <sub>f</sub>	Input Rise and Fall Time V <sub>CC</sub> = 2.5 V ±0.2 V V <sub>CC</sub> = 3.0 V ±0.3 V V <sub>CC</sub> = 5.0 V ±0.5 V	0	20	ns/V
		0	10	
		0	5	

**Electrical Characteristics**
**DC ELECTRICAL CHARACTERISTICS**

Symbol	Parameter	Condition	V <sub>CC</sub> (V)	T <sub>A</sub> = 25 °C			-55°C ≤ T <sub>A</sub> ≤ 125°C		Unit
				Min	Typ	Max	Min	Max	
V <sub>IH</sub>	High-Level Input Voltage		1.65to1.95 2.3 to 5.5	0.75V <sub>CC</sub> 0.7V <sub>CC</sub>			0.75V <sub>CC</sub> 0.7V <sub>CC</sub>	V	
V <sub>IL</sub>	Low-Level Input Voltage		1.65to1.95 2.3 to 5.5			0.25V <sub>CC</sub> 0.3V <sub>CC</sub>		0.25V <sub>CC</sub> 0.3V <sub>CC</sub>	V
V <sub>OH</sub>	High-Level Output Voltage V <sub>IN</sub> = V <sub>IL</sub>	I <sub>OH</sub> = -100uA	1.65to5.5	V <sub>CC</sub> -0.1	V <sub>CC</sub>		V <sub>CC</sub> -0.1		V
		I <sub>OH</sub> = -3mA	1.65	1.29	1.52		1.29		
		I <sub>OH</sub> = -8mA	2.3	1.9	2.1		1.9		
		I <sub>OH</sub> = -12mA	2.7	2.2	2.4		2.2		
		I <sub>OH</sub> = -16mA	3.0	2.4	2.7		2.4		
		I <sub>OH</sub> = -24mA	3.0	2.3	2.5		2.3		
		I <sub>OH</sub> = -32mA	4.5	3.8	4.0		3.8		
V <sub>OL</sub>	Low-Level Output Voltage V <sub>IN</sub> = V <sub>IH</sub>	I <sub>OH</sub> = 100uA	1.65to5.5		0.0	0.1		0.1	V
		I <sub>OL</sub> = 3mA	1.65		0.08	0.24		0.24	
		I <sub>OL</sub> = 8mA	2.3		0.20	0.3		0.3	
		I <sub>OL</sub> = 12mA	2.7		0.22	0.4		0.4	
		I <sub>OL</sub> = 16mA	3.0		0.28	0.4		0.4	
		I <sub>OL</sub> = 24mA	3.0		0.38	0.55		0.55	
		I <sub>OL</sub> = 32mA	4.5		0.42	0.55		0.55	
I <sub>IN</sub>	Input Leakage Current	V <sub>IN</sub> = 5.5V or GND	0 to 5.5		±0.1			±1.0	uA
I <sub>OFF</sub>	Power Off Leakage Current	V <sub>IN</sub> = 5.5V or V <sub>OUT</sub> = 5.5V	0			1		10	uA
I <sub>CC</sub>	Quiescent Supply Current	V <sub>IN</sub> = 5.5V or GND	5.5					10	uA

Product parametric performance is indicated in the Electrical Characteristics for the listed test conditions, unless

otherwise noted. Product performance may not be indicated by the Electrical Characteristics if operated under different conditions.

**AC ELECTRICAL CHARACTERISTICS  $t_r=t_f= 2.5\text{ns}$ ;  $C_L = 50\text{pF}$ ;**

**$R_L = 500 \Omega$**

Symbol	Parameter	Condition	$V_{CC}(\text{V})$	$T_A = 25^\circ\text{C}$			$-55^\circ\text{C} \leq T_A \leq 125^\circ\text{C}$		Unit
				Min	Typ	Max	Min	Max	
$t_{PLH}$ $t_{PHL}$	Propagation Delay (Figure 3 and 4)	$R_L = 1\text{M}\Omega$ $C_L = 15\text{pF}$	1.65	2.0	5.3	11.4	2.0	12.0	ns
			1.8	2.0	4.4	9.5	2.0	10.0	
		$R_L = 1\text{M}\Omega$ $C_L = 15\text{pF}$	$2.5 \pm 0.2$	0.2	3.5	6.5	0.8	7.0	
		$R_L = 1\text{M}\Omega$ $C_L = 15\text{pF}$	$3.3 \pm 0.3$	0.8	2.1	4.5	0.5	4.7	
		$R_L = 500\Omega$ $C_L = 50\text{pF}$		1.2	2.9	5.5	1.5	5.2	
		$R_L = 1\text{M}\Omega$ $C_L = 15\text{pF}$	$5.0 \pm 0.5$	0.5	1.8	3.9	0.5	4.1	
$R_L = 500\Omega$ $C_L = 50\text{pF}$	0.8	2.4		4.3	0.8	4.5			

**CAPACITIVE CHARACTERISTICS**

Symbol	Parameter	Condition	Typical	Unit
$C_{IN}$	Input Capacitance	$V_{CC} = 5.5\text{V}$ , $V_I = 0\text{V}$ or $V_{CC}$	>2.5	pF
$C_{PD}$	Power Dissipation Capacitance (Note 6)	10 MHz, $V_{CC} = 3.3\text{V}$ , $V_I = 0\text{V}$ or $V_{CC}$	9	pF (Note 6)
		10 MHz, $V_{CC} = 5.5\text{V}$ , $V_I = 0\text{V}$ or $V_{CC}$	11	

6.  $C_{PD}$  is defined as the value of the internal equivalent capacitance which is calculated from the operating current consumption without load. Average operating current can be obtained by the equation:

$$I_{CC(OPR)} = C_{PD} * V_{CC} * f_{in} + I_{CC} * C_{PD}$$

is used to determine the no-load dynamic power consumption;

$$P_D = C_{PD} * V_{CC}^2 * f_{in} + I_{CC} * V_{CC} * Fig.$$

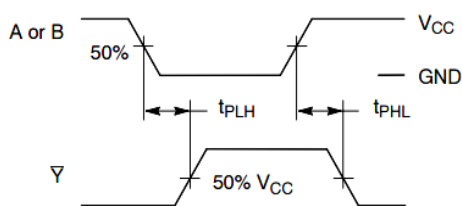
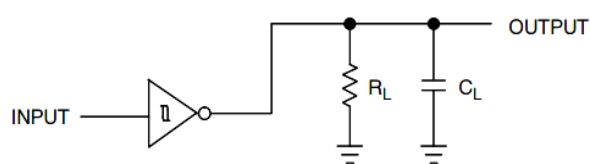

Figure 3. Switching Waveform



A 1-MHz square input wave is recommended for propagation delay tests.

Figure 4. Test Circuit

Package Dimension

SC70-5

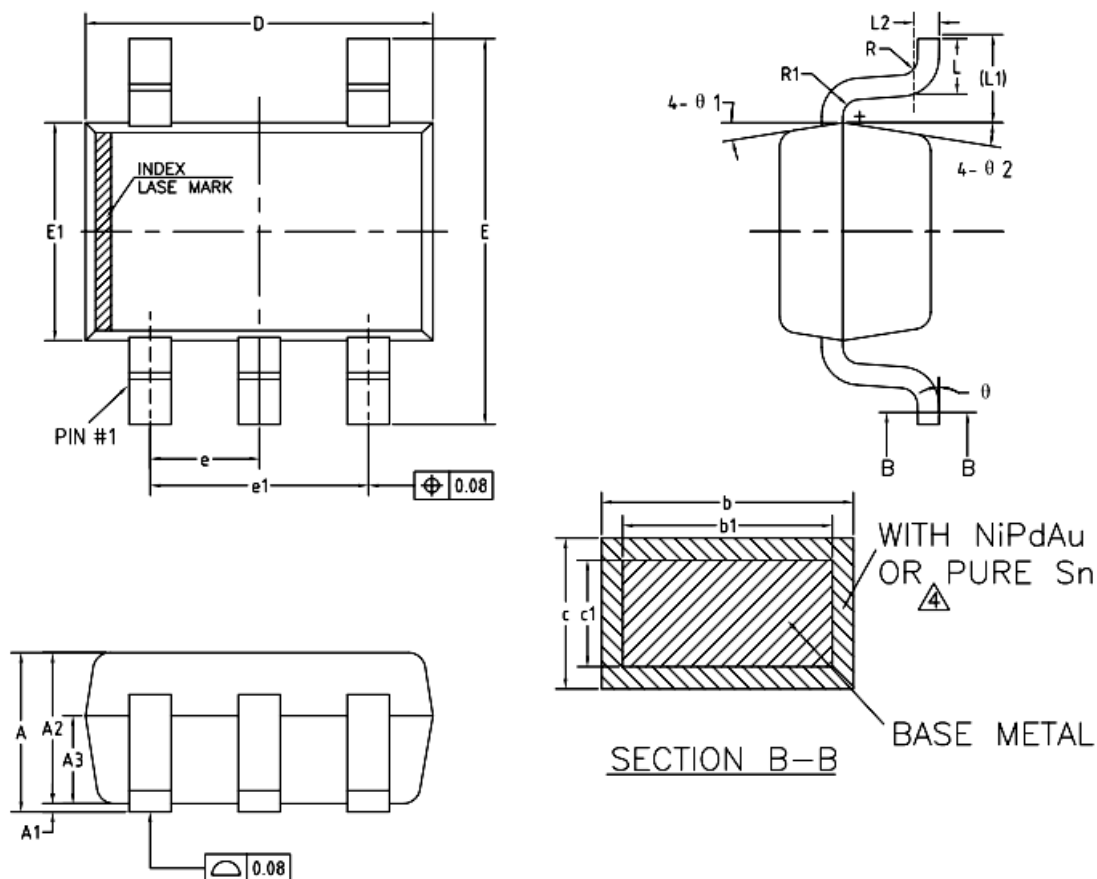



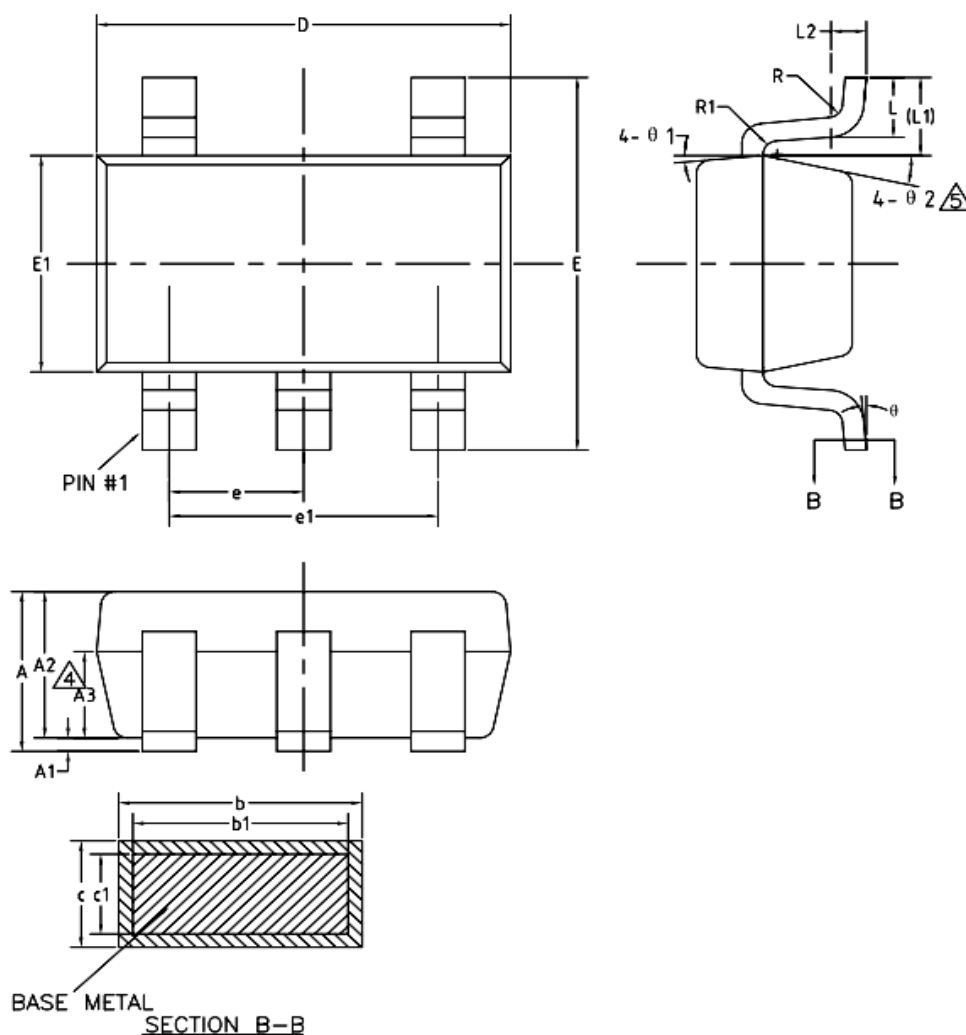

COMMON DIMENSIONS  
(UNITS OF MEASURE=MILLIMETER)

SYMBOL	MIN	NOM	MAX
A	0.85	—	1.05
A1	0	—	0.10
A2	0.80	0.90	1.00
A3	0.47	0.52	0.57
b	NiPd Au 0.22	—	0.29
	PURE Sn 0.23	—	0.33
b1	0.22	0.25	0.28
c	NiPd Au 0.115	—	0.15
	PURE Sn 0.12	—	0.18
c1	0.115	0.13	0.14
D	2.02	2.07	2.12
E	2.20	2.30	2.40
E1	1.25	1.30	1.35
e	0.60	0.65	0.70
e1	1.20	1.30	1.40
L	0.28	0.33	0.38
L1	0.50REF		
L2	0.15BSC		
R	0.10	—	—
R1	0.10	—	0.25
θ	0°	—	8°
θ 1	6°	9°	12°
θ 2	6°	9°	12°

SOT23-5



COMMON DIMENSIONS  
(UNITS OF MEASURE=MILLIMETER)

SYMBOL	MIN	NOM	MAX
A	—	—	1.25
 A1	0	—	0.15
A2	1.00	1.10	1.20
A3	0.60	0.65	0.70
b	0.36	—	0.50
b1	0.36	0.38	0.45
c	0.14	—	0.20
c1	0.14	0.15	0.16
D	2.826	2.926	3.026
E	2.60	2.80	3.00
E1	1.526	1.626	1.726
 e	0.90	0.95	1.00
 e1	1.80	1.90	2.00
L	0.35	0.45	0.60
L1	0.59REF		
L2	0.25BSC		
R	0.10	—	—
R1	0.10	—	0.25
θ	0°	—	8°
 θ 1	3°	5°	7°
 θ 2	6°	—	14°

DFN6

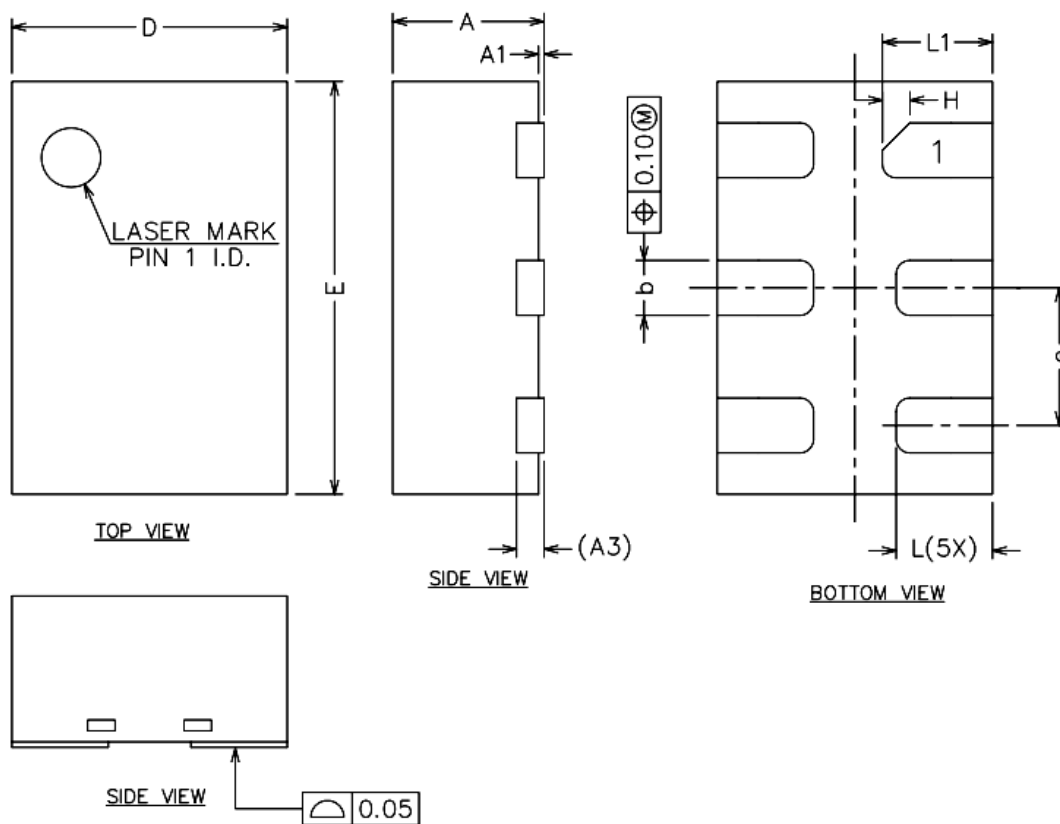

COMMON DIMENSIONS  
(UNITS OF MEASURE=MILLIMETER)

SYMBOL	MIN	NOM	MAX
A	0.50	-	0.60
A1	0.00	0.02	0.05
A3	0.10REF		
b	0.15	0.20	0.25
D	0.90	1.00	1.10
E	1.40	1.50	1.60
e	0.40	0.50	0.60
H	0.10REF		
L	0.30	0.35	0.40
L1	0.35	0.40	0.45



**Ordering information**

Order code	Marking code	Package	Baseqty	Deliverymode
UMW SN74LVC1G17DBVR	C17J	SOT23-5	3000	Tape and reel
UMW SN74LVC1G17DCKR	C75	SC70-5	3000	Tape and reel
UMW SN74LVC1G17DRYR	C7	DFN6	3000	Tape and reel

## X-ON Electronics

Largest Supplier of Electrical and Electronic Components

*Click to view similar products for [Logic Gates](#) category:*

*Click to view products by [Youtai](#) manufacturer:*

Other Similar products are found below :

[74HC85N](#) [NL17SG32DFT2G](#) [CD4068BE](#) [NL17SG86DFT2G](#) [NLV14001UBDR2G](#) [NLX1G11AMUTCG](#) [NLX1G97MUTCG](#) [74LS38](#)  
[74LVC1G08Z-7](#) [74LVC32ADTR2G](#) [CD4025BE](#) [MC74HCT20ADTR2G](#) [NLV17SZ00DFT2G](#) [NLV17SZ126DFT2G](#) [NLV27WZ17DFT2G](#)  
[NLV74HC02ADR2G](#) [74HC32S14-13](#) [74LS133](#) [74LVC1G32Z-7](#) [74LVC1G86Z-7](#) [NLV74HC14ADR2G](#) [NLV74HC20ADR2G](#)  
[NLVVHC1G09DFT1G](#) [NLX2G86MUTCG](#) [74LVC2G32RA3-7](#) [74LVC2G00HD4-7](#) [NL17SG02P5T5G](#) [74LVC2G86HK3-7](#)  
[NLV7SZ97DFT2G](#) [NLVVHC1G14DFT2G](#) [NLX1G99DMUTWG](#) [NLVVHC1G00DFT2G](#) [NLV7SZ57DFT2G](#) [NLV74VHC04DTR2G](#)  
[NLV27WZ00USG](#) [NLU1G86CMUTCG](#) [NLU1G08CMUTCG](#) [NL17SZ32P5T5G](#) [NL17SZ00P5T5G](#) [NL17SH02P5T5G](#) [74AUP2G00RA3-7](#)  
[NLVVHC1GT00DFT2G](#) [NLV74HC02ADTR2G](#) [NLX1G332CMUTCG](#) [NLVHCT132ADTR2G](#) [NL17SG86P5T5G](#) [NL17SZ05P5T5G](#)  
[NLV74VHC00DTR2G](#) [NLVVHC1G02DFT1G](#) [NLV74HC86ADR2G](#)