

### General Description

The SN74LVC1G32 is a single 2-input OR Gate in three tiny footprint packages. The device performs much as LCX multi-gate products in speed and drive.

### Features

- Tiny SC70-5 /SOT23-5/DFN Packages
- 2.4ns  $t_{PD}$  at 5V (typ)
- Source/Sink 24mA at 3.0V
- Over-Voltage Tolerant Inputs
- Designed for 1.65V to 5.5V  $V_{CC}$  Operation
- These Devices are Pb-Free and are RoHS Compliant

### Pin Configuration

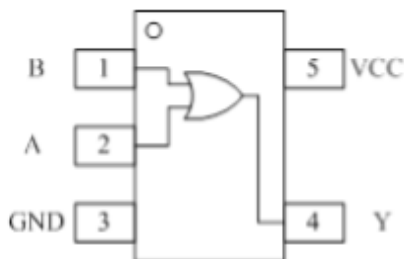

SC70-5/SOT23-5

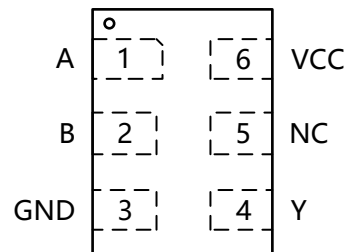

DFN6

Figure1: Top View

**Pin Function**

(SC70 -5/ SOT23-5 /DFN6)

PIN	FUNCTION
1	IN B
2	INA
3	GND
4	Y
5	VCC

**Block Diagram**

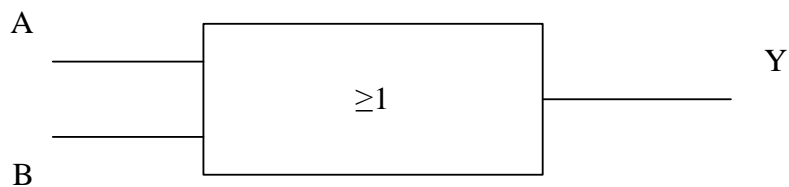

Figure2.Logic symbol

**Functional Description**

**Function Table**

Input		Output
A	B	Y
L	L	L
L	H	H
H	L	H
H	H	H

**Absolute Maximum Ratings**

Symbol	Parameter	Value	Unit
$V_{CC}$	DC Supply Voltage	-0.5 to 7.0	V
$V_I$	DC Input Voltage	$-0.5 \leq V_I \leq +7.0$	V
$V_O$	DC Output Voltage Output in Higher or Low State	-0.5 to $V_{CC} + 0.5$	V
$I_{IK}$	DC Input Diode Current $V_I < GND$	-50	mA
$I_{OK}$	DC Output Diode Current $V_O < GND, V_O > V_{CC}$	$\pm 50$	mA
$I_O$	DC Output Sink Current	$\pm 50$	mA
$I_{CC}$	DC Supply Current per Supply Pin	$\pm 100$	mA
$I_{GND}$	DC Ground Current per Supply Pin	$\pm 100$	mA
$T_{STG}$	Storage Temperature Range	-65 to 150	°C
$T_L$	Lead Temperature, 1 mm from Case for 10 Seconds	260	°C
$T_J$	Junction Temperature Under Bias	150	°C
$\theta_{JA}$	Thermal Resistance SC70-5 SOT23-5	435	°C/W
		300	
		423	
$P_D$	Power Dissipation in Still Air at 85°C	200	mW
MSL	Moisture Sensitivity	Level 1	
ESD	ESD Classification Human Body Model (Note 2)	2000	V
	Machine Model (Note 3)	200	
	Charged Device Model (Note 4)	N/A	
$I_{Latchup}$	Latchup Performance Above $V_{CC}$ and Below GND at 125°C (Note 5)	$\pm 100$	mA

Stresses exceeding those listed in the Maximum Ratings table may damage the device. If any of these limits are exceeded, device functionality should not be assumed, damage may occur and reliability may be affected.

1. IO absolute maximum rating must be observed.
2. Tested to EIA/JESD22-A114-A, rated to EIA/JESD22-A114-B.
3. Tested to EIA/JESD22-A115-A, rated to EIA/JESD22-A115-A.
4. Tested to JESD22-C101-A.
5. Tested to EIA/JESD78

**Recommended Operating Conditions**

Symbol	Parameter	Min	Max	Unit	
$V_{CC}$	DC Supply Voltage Operating	1.65	5.5	V	
	Date Retention	1.5	5.5		
$V_{IN}$	DC Input Voltage	0	5.5	V	
$V_{OUT}$	DC Output Voltage (High or Low State)	0	5.5	V	
$T_A$	Operating Temperature Range	-40	85	°C	
$t_r, t_f$	Input Rise and Fall Time	$V_{CC} = 2.5 V \pm 0.2 V$	0	20	ns/V
		$V_{CC} = 3.0 V \pm 0.3 V$	0	10	
		$V_{CC} = 5.0 V \pm 0.5 V$	0	5	

**Electrical Characteristics**
**DC ELECTRICAL CHARACTERISTICS**

Symbol	Parameter	Condition	V <sub>CC</sub> (V)	TA = 25 °C			-40 °C ≤ TA ≤ 85 °C		Unit
				Min	Typ	Max	Min	Max	
V <sub>IH</sub>	High-Level Input Voltage		1.65 to 1.95 2.3 to 5.5	0.75V <sub>CC</sub> 0.7V <sub>CC</sub>			0.75V <sub>CC</sub> 0.7V <sub>CC</sub>		V
V <sub>IL</sub>	Low-Level Input Voltage		1.65 to 1.95 2.3 to 5.5			0.25V <sub>CC</sub> 0.3V <sub>CC</sub>		0.25V <sub>CC</sub> 0.3V <sub>CC</sub>	V
V <sub>OH</sub>	High-Level Output Voltage V <sub>IN</sub> = V <sub>IL</sub>	I <sub>OH</sub> = -100µA	1.65 to 5.5	V <sub>CC</sub> - 0.1	V <sub>CC</sub>		V <sub>CC</sub> - 0.1		V
		I <sub>OH</sub> = -3mA	1.65	1.29	1.52		1.29		
		I <sub>OH</sub> = -8mA	2.3	1.9	2.1		1.9		
		I <sub>OH</sub> = -12mA	2.7	2.2	2.4		2.2		
		I <sub>OH</sub> = -16mA	3.0	2.4	2.7		2.4		
		I <sub>OH</sub> = -24mA	3.0	2.3	2.5		2.3		
		I <sub>OH</sub> = -32mA	4.5	3.8	4.0		3.8		
V <sub>OL</sub>	Low-Level Output Voltage V <sub>IN</sub> = V <sub>IH</sub>	I <sub>OH</sub> = 100µA	1.65 to 5.5		0.0	0.1		0.1	V
		I <sub>OL</sub> = 3mA	1.65		0.08	0.24		0.24	
		I <sub>OL</sub> = 8mA	2.3		0.20	0.3		0.3	
		I <sub>OL</sub> = 12mA	2.7		0.22	0.4		0.4	
		I <sub>OL</sub> = 16mA	3.0		0.28	0.4		0.4	
		I <sub>OL</sub> = 24mA	3.0		0.38	0.55		0.55	
		I <sub>OL</sub> = 32mA	4.5		0.42	0.55		0.55	
I <sub>IN</sub>	Input Leakage Current	V <sub>IN</sub> = 5.5V or GND	0 to 5.5		±0.1			±1.0	µA
I <sub>OFF</sub>	Power Off Leakage Current	V <sub>IN</sub> = 5.5V or V <sub>OUT</sub> = 5.5V	0			1		10	µA
I <sub>CC</sub>	Quiescent Supply Current	V <sub>IN</sub> = 5.5V or GND	5.5					10	µA

Product parametric performance is indicated in the Electrical Characteristics for the listed test conditions, unless otherwise noted. Product performance may not be indicated by the Electrical Characteristics if operated under different conditions.

**AC ELECTRICAL CHARACTERISTICS**

$t_r=t_f=3\text{ns}$ ;

Symbol	Parameter	Condition	$V_{CC}(V)$	TA = 25 °C			-40°C ≤TA≤85°C		Unit
				Min	Typ	Max	Min	Max	
$t_{PD}$	Propagation Delay (Figure3and4)	$R_L=1\text{M}\Omega$ $C_L=15\text{pF}$	1.65	2.0	10.1	12.9	2.0	13.9	ns
			1.8	2.0	9.1	11.6	2.0	12.4	
		$R_L=1\text{M}\Omega$ $C_L=15\text{pF}$	2.5	0.2	6.0	7.7	0.8	8.2	
			3.3	$R_L=1\text{M}\Omega$ $C_L=15\text{pF}$	0.8	5.0	6.5	0.5	
		$R_L=500\Omega$ $C_L=50\text{pF}$		1.2	5.6	7.1	1.5	7.6	
		5.0	$R_L=1\text{M}\Omega$ $C_L=15\text{pF}$	0.5	4.4	5.6	0.5	6.1	
			$R_L=500\Omega$ $C_L=50\text{pF}$	0.8	4.8	6.1	0.8	6.6	

**CAPACITIVE CHARACTERISTICS**

Symbol	Parameter	Condition	Typical	Unit
$C_{IN}$	Input Capacitance	$V_{CC}=5.5\text{V}$ , $V_I=0\text{V}$ or $V_{CC}$	>2.5	pF
$C_{PD}$	Power Dissipation Capacitance (Note 6)	10MHz, $V_{CC}=3.3\text{V}$ , $V_I=0\text{V}$ or $V_{CC}$	21	pF
		10MHz, $V_{CC}=5.5\text{V}$ , $V_I=0\text{V}$ or $V_{CC}$	21	

6.  $C_{PD}$  is defined as the value of the internal equivalent capacitance which is calculated from the operating current consumption without load. Average operating current can be obtained by the equation:

$I_{CC(OPR)}=C_{PD} \cdot V_{CC} \cdot f_{in} + I_{CC} \cdot C_{PD}$  is used to determine the no-load dynamic power consumption;

$P_D=C_{PD} \cdot V_{CC}^2 \cdot f_{in} + I_{CC} \cdot V_{CC} \cdot Fig.$

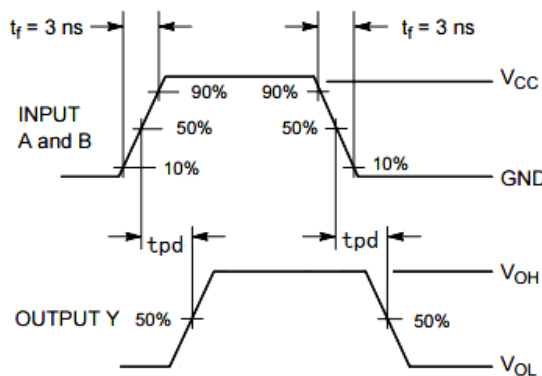

Figure 3. Switching Waveform

PROPAGATION DELAYS

$t_r = t_f = 3\text{ns}$ , 10% to 90%;

$f = 1\text{MHz}$ ;  $t_W = 500\text{ns}$

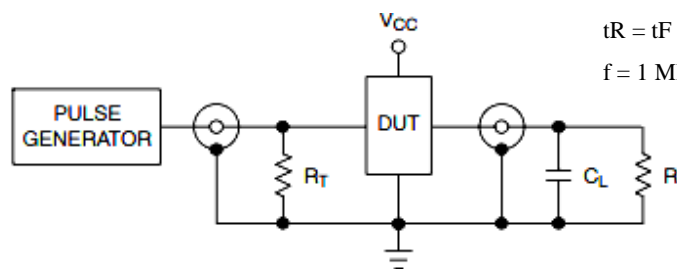
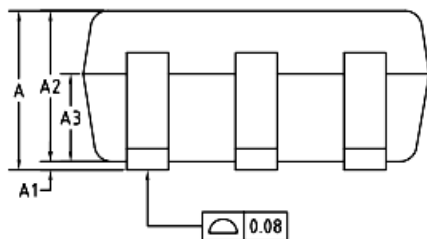
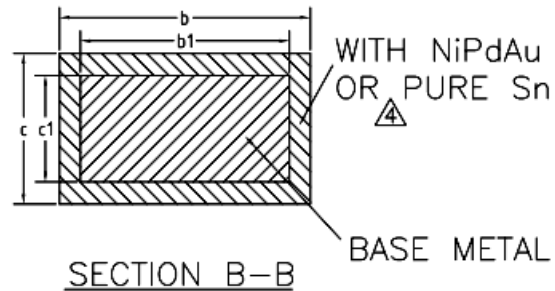
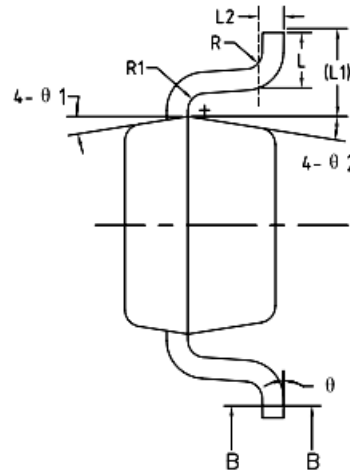
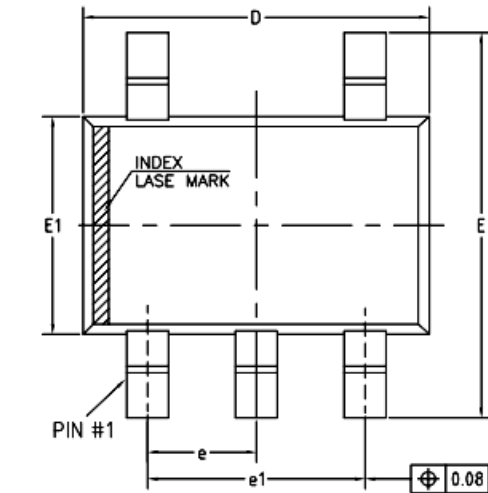

Figure 4. Test Circuit

Package Dimension

SC70-5



COMMON DIMENSIONS  
(UNITS OF MEASURE=MILLIMETER)

SYMBOL	MIN	NOM	MAX	
A	0.85	—	1.05	
A1	0	—	0.10	
A2	0.80	0.90	1.00	
A3	0.47	0.52	0.57	
b	NiPdAu	0.22	—	0.29
	PURE Sn	0.23	—	0.33
b1	0.22	0.25	0.28	
c	NiPdAu	0.115	—	0.15
	PURE Sn	0.12	—	0.18
c1	0.115	0.13	0.14	
D	2.02	2.07	2.12	
E	2.20	2.30	2.40	
E1	1.25	1.30	1.35	
e	0.60	0.65	0.70	
e1	1.20	1.30	1.40	
L	0.28	0.33	0.38	
L1	0.50REF			
L2	0.15BSC			
R	0.10	—	—	
R1	0.10	—	0.25	
θ	0°	—	8°	
θ 1	6°	9°	12°	
θ 2	6°	9°	12°	

SOT23-5

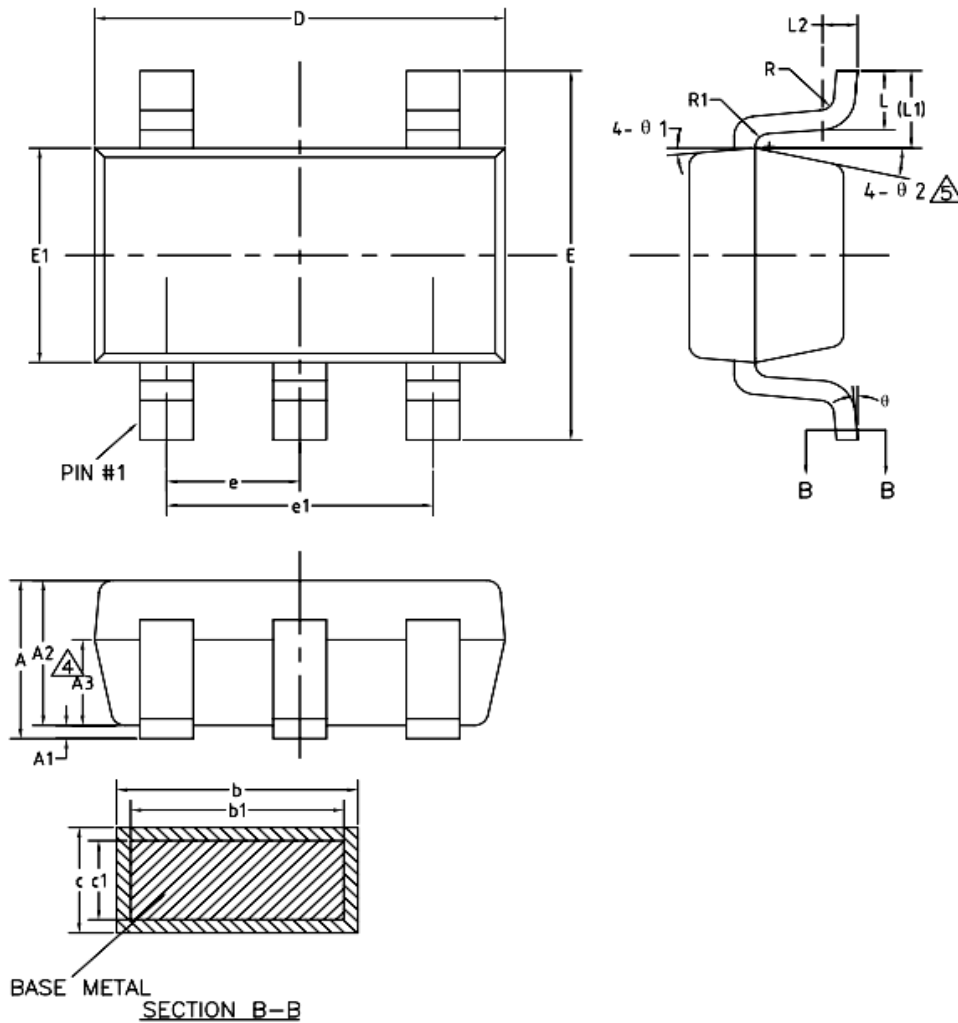

COMMON DIMENSIONS  
(UNITS OF MEASURE=MILLIMETER)

SYMBOL	MIN	NOM	MAX
A	—	—	1.25
$\triangle$ A1	0	—	0.15
A2	1.00	1.10	1.20
A3	0.60	0.65	0.70
b	0.36	—	0.50
b1	0.36	0.38	0.45
c	0.14	—	0.20
c1	0.14	0.15	0.16
D	2.826	2.926	3.026
E	2.60	2.80	3.00
E1	1.526	1.626	1.726
e	0.90	0.95	1.00
$\triangle$ e1	1.80	1.90	2.00
L	0.35	0.45	0.60
L1	0.59REF		
L2	0.25BSC		
R	0.10	—	—
R1	0.10	—	0.25
$\theta$	0°	—	8°
$\theta$ 1	3°	5°	7°
$\triangle$ $\theta$ 2	6°	—	14°

DFN6(1.0×1.5)

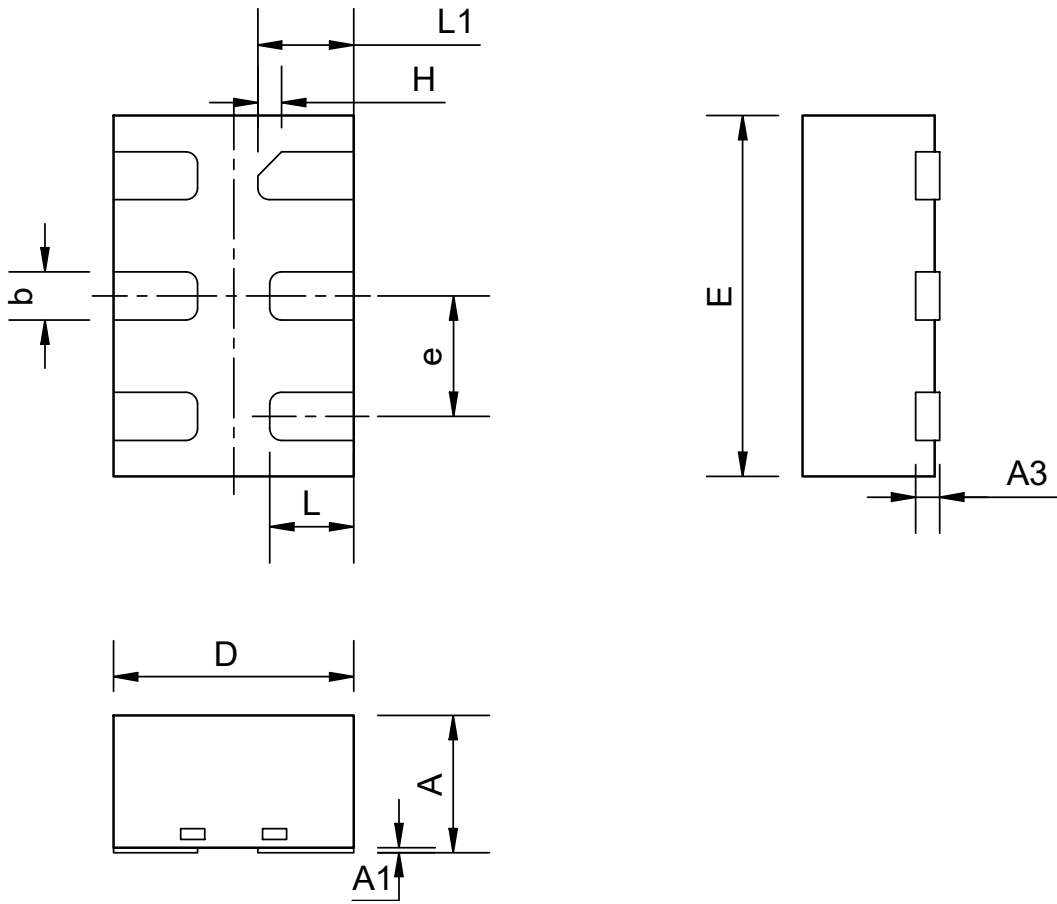

COMMON DIMENSIONS  
(UNITS OF MEASURE=MILLIMETER)

SYMBOL	MIN	NOM	MAX
A	0.50	--	0.60
A1	0	0.02	0.05
A3	0.10REF		
b	0.15	0.20	0.25
D	0.90	1.00	1.10
E	1.40	1.50	1.60
e	0.40	0.50	0.60
H	0.10REF		
L	0.30	0.35	0.40
L1	0.35	0.40	0.45



**Ordering information**

Order code	Marking code	Package	Baseqty	Deliverymode
UMW SN74LVC1G32DBVR	C32R	SOT23-5	3000	Tape and reel
UMW SN74LVC1G32DCKR	CG5	SC70-5	3000	Tape and reel
UMW SN74LVC1G32DRYR	CG	DFN6	5000	Tape and reel

## X-ON Electronics

Largest Supplier of Electrical and Electronic Components

*Click to view similar products for [Buffers & Line Drivers](#) category:*

*Click to view products by [Youtai](#) manufacturer:*

Other Similar products are found below :

[LXV200-024SW](#) [74AUP2G34FW3-7](#) [HEF4043BP](#) [NL17SG125DFT2G](#) [NLU1GT126CMUTCG](#) [CD4041UBE](#) [54FCT240CTDB](#)  
[74HCT540N](#) [DS14C88N](#) [070519XB](#) [NL17SZ07P5T5G](#) [74LVC2G17FW4-7](#) [CD4502BE](#) [5962-8982101PA](#) [61446R00](#) [NL17SH17P5T5G](#)  
[NLV37WZ17USG](#) [74HCT126T14-13](#) [74VHC9126FT\(BJ\)](#) [RHRXH162244K1](#) [74AUP1G34FW5-7](#) [74AUP1G07FW5-7](#) [74LVC1G126FW4-7](#)  
[74LVC2G126RA3-7](#) [74LVCE1G125FZ4-7](#) [54FCT240TLB](#) [NLX3G16DMUTCG](#) [NLX2G06AMUTCG](#) [LE87100NQCT](#) [LE87285NQC](#)  
[LE87290YQC](#) [LE87290YQCT](#) [74AUP1G125FW5-7](#) [NLU2G16CMUTCG](#) [MC74LCX244MN2TWG](#) [NL17SG17P5T5G](#)  
[NLV74HC125ADR2G](#) [NLVHCT245ADTR2G](#) [NLVVHC1G126DFT2G](#) [EL5623IRZ](#) [ISL15102AIRZ-T13](#) [ISL1539IRZ-T13](#)  
[MC100EP17MNG](#) [MC74HCT365ADR2G](#) [MC74LCX244ADTR2G](#) [NL27WZ126US](#) [NL37WZ16US](#) [NLU1G07MUTCG](#) [NLU2G07MUTCG](#)  
[NLX3G17BMX1TCG](#)