

General Description

The SN74LVC2G07 is a high performance dual buffer with open drain outputs operating from a 1.65 to 5.5V supply. The internal circuit is composed of multiple stages, including an open drain output. The open drain output provides the capability to set the output switching level to a user selectable value with an external resistor and power supply.

The logic high output value is set by the external power supply and can be less than, equal or greater than the VCC power supply, provided the voltage supply is less than 5.5V.

Features

- Extremely High Speed: t_{PD} 2.3ns (typical) at $V_{CC} = 5V$
- Designed for 1.65V to 5.5V V_{CC} Operation, CMOS compatible
- Over Voltage Tolerant Inputs
- LVTTTL Compatible – Interface Capability with 5V TTL Logic with $V_{CC} = 3V$
- LVCMOS Compatible
- 24mA Output Sink Capability
- Near Zero Static Supply Current Substantially Reduces System Power Requirements
- Chip Complexity: FET = 72; Equivalent Gate = 18
- These Devices are Pb– Free and are RoHS Compliant

Pin Configuration

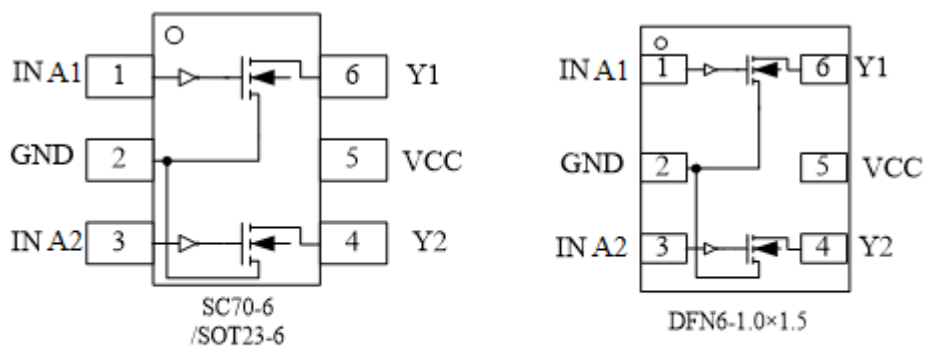

Figure 1. Pinouts (Top View)

Pin Function

PIN	ASSIGNMENT
1	IN A1
2	GND
3	IN A2
4	Y2
5	VCC
6	Y1

Block Diagram

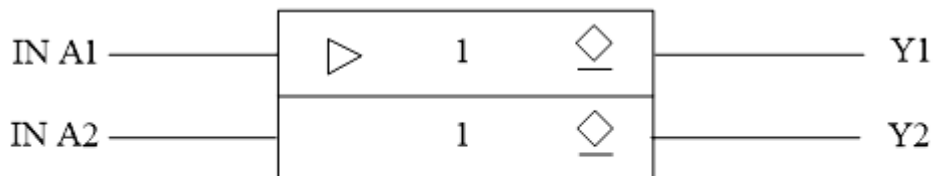

Figure2.Logic symbol

Functional Description

Function Table

A Input	Y Output
L	L
H	Z

Absolute Maximum Ratings

Symbol	Parameter	Value	Unit
V _{CC}	DC Supply Voltage	-0.5 to 7.0	V
V _I	DC Input Voltage	-0.5 ≤ V _I ≤ +7.0	V
V _O	DC Output Voltage Output in Higher or Low State (Note 1)	-0.5 to V _{CC} + 0.5	V
I _{IK}	DC Input Diode Current V _I < GND	-50	mA
I _{OK}	DC Output Diode Current V _O < GND, V _O > V _{CC}	±50	mA
I _O	DC Output Sink Current	±50	mA
I _{CC}	DC Supply Current per Supply Pin	±100	mA
I _{GND}	DC Ground Current per Supply Pin	±100	mA
T _{STG}	Storage Temperature Range	-65 to 150	°C
T _L	Lead Temperature, 1 mm from Case for 10 Seconds	260	°C
T _J	Junction Temperature Under Bias	150	°C
θ _{JA}	Thermal Resistance	333	°C/W
P _D	Power Dissipation in Still Air at 85 °C	200	mW
MSL	Moisture Sensitivity	Level 1	
F _R	Flammability Rating Oxygen Index:28 to 34	UL94V-0@0.12in	
ESD	ESD Classification Human Body Model (Note 2)	2000	V
	Machine Model (Note3)	200	
	Charged Device Model (Note 4)	N/A	
I _{Latchup}	Latchup Performance Above V _{CC} and Below GND at 125 °C (Note 5)	±100	mA

Stresses exceeding those listed in the Maximum Ratings table may damage the device. If any of these limits are exceeded, device functionality should not be assumed, damage may occur and reliability may be affected.

1. IO absolute maximum rating must be observed.
2. Tested to EIA/JESD22-A114-A, rated to EIA/JESD22-A114-B.
3. Tested to EIA/JESD22-A115-A, rated to EIA/JESD22-A115-A.
4. Tested to JESD22-C101-A.
5. Tested to EIA/JESD78.

Recommended Operating Conditions

Symbol	Parameter	Min	Max	Unit
V _{CC}	DC Supply Voltage Operating	1.65	5.5	V
	Date Retention	1.5	5.5	
V _{IN}	DC Input Voltage	0	5.5	V
V _{OUT}	DC Output Voltage (High or Low State)	0	5.5	V
T _A	Operating Temperature Range	-55	125	°C
t _r , t _f	Input Rise and Fall Time V _{CC} = 2.5 V ± 0.2 V	0	20	ns/V
	V _{CC} = 3.0 V ± 0.3 V	0	10	
	V _{CC} = 5.0 V ± 0.5 V	0	5	

Functional operation above the stresses listed in the Recommended Operating Ranges is not implied. Extended exposure to stresses beyond the Recommended.

Electrical Characteristics

DC ELECTRICAL CHARACTERISTICS

Symbol	Parameter	Condition	VCC(V)	TA = 25 °C			-55°C ≤ TA ≤ 125°C		Unit
				Min	Typ	Max	Min	Max	
V _{IH}	High-Level Input Voltage		1.65 to 1.95 2.3 to 5.5	0.75V _{CC} 0.7V _{CC}			0.75V _{CC} 0.7V _{CC}		V
V _{IL}	Low-Level Input Voltage		1.65 to 1.95 2.3 to 5.5			0.25V _{CC} 0.3V _{CC}		0.25V _{CC} 0.3V _{CC}	V
V _{OL}	Low-Level Output Voltage V _{IN} = V _{IH}	I _{OH} = 100µA	1.65 to 5.5		0.0	0.1		0.1	V
		I _{OL} = 3mA	1.65		0.08	0.24		0.24	
		I _{OL} = 8mA	2.3		0.20	0.3		0.3	
		I _{OL} = 12mA	2.7		0.22	0.4		0.4	
		I _{OL} = 16mA	3.0		0.28	0.4		0.4	
		I _{OL} = 24mA	3.0		0.38	0.55		0.55	
		I _{OL} = 32mA	4.5		0.42	0.55		0.55	
I _{IN}	Input Leakage Current	V _{IN} = 5.5V or GND	0 to 5.5		±0.1			±1.0	µA
I _{OFF}	Power Off Leakage Current	V _{IN} = 5.5V or V _{OUT} = 5.5V	0			1		10	µA
I _{CC}	Quiescent Supply Current	V _{IN} = 5.5V or GND	5.5					10	µA

Product parametric performance is indicated in the Electrical Characteristics for the listed test conditions, unless otherwise noted. Product performance may not be indicated by the Electrical Characteristics if operated under different conditions.

**AC ELECTRICAL CHARACTERISTICS $t_r=t_f= 2.5\text{ns}$; $C_L = 50\text{pF}$;
 $R_L = 500 \Omega$**

Symbol	Parameter	Condition	$V_{CC}(\text{V})$	$T_A = 25^\circ\text{C}$			$-55^\circ\text{C} \leq T_A \leq 125^\circ\text{C}$		Unit
				Min	Typ	Max	Min	Max	
t_{PLH} t_{PHL}	Propagation Delay (Figure3and4)	$R_L = 1\text{M}\Omega$ $C_L = 15\text{pF}$	1.65	2.0	5.3	11.4	2.0	12.0	ns
			1.8	2.0	4.4	9.5	2.0	10.0	
		$R_L = 1\text{M}\Omega$ $C_L = 15\text{pF}$	2.5 ± 0.2	0.2	3.5	6.5	0.8	4.1	
		$R_L = 1\text{M}\Omega$ $C_L = 15\text{pF}$	3.3 ± 0.3	0.8	2.1	4.5	0.5	3.7	
		$R_L = 500\Omega$ $C_L = 50\text{pF}$		1.2	2.9	5.5	1.5	5.2	
		$R_L = 1\text{M}\Omega$ $C_L = 15\text{pF}$	5.0 ± 0.5	0.5	1.8	3.9	0.5	4.1	
$R_L = 500\Omega$ $C_L = 50\text{pF}$	0.8	2.4		4.3	0.8	4.5			

CAPACITIVE CHARACTERISTICS

Symbol	Parameter	Condition	Typical	Unit
C_{IN}	Input Capacitance	$V_{CC} = 5.5\text{V}$, $V_I = 0\text{V}$ or V_{CC}	>2.5	pF
C_{PD}	Power Dissipation Capacitance (Note 6)	10MHz, $V_{CC} = 3.3\text{V}$, $V_I = 0\text{V}$ or V_{CC}	4	pF
		10MHz, $V_{CC} = 5.5\text{V}$, $V_I = 0\text{V}$ or V_{CC}	4	

6. C_{PD} is defined as the value of the internal equivalent capacitance which is calculated from the operating current consumption without load. Average operating current can be obtained by the equation:

$I_{CC(OPR)} = C_{PD} * V_{CC} * f_{in} + I_{CC} * C_{PD}$ is used to determine the no-load dynamic power consumption;

$P_D = C_{PD} * V_{CC}^2 * f_{in} + I_{CC} * V_{CC} * Fig.$

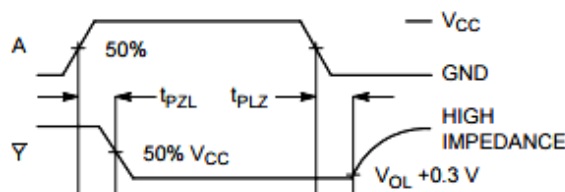
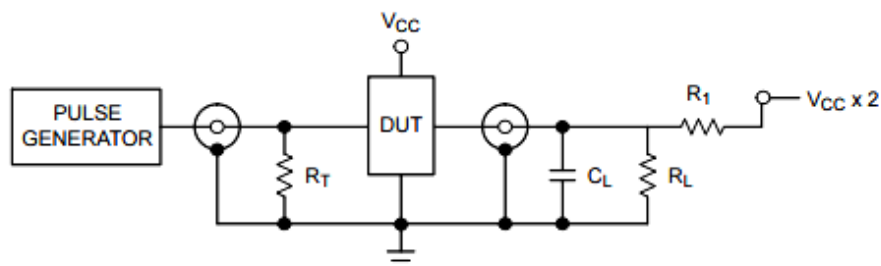

Figure 3. Switching Waveforms



$R_T = Z_{OUT}$ of pulse generator (typically 50Ω)

Figure 4. Test Circuit

Package Dimension

SC70-6

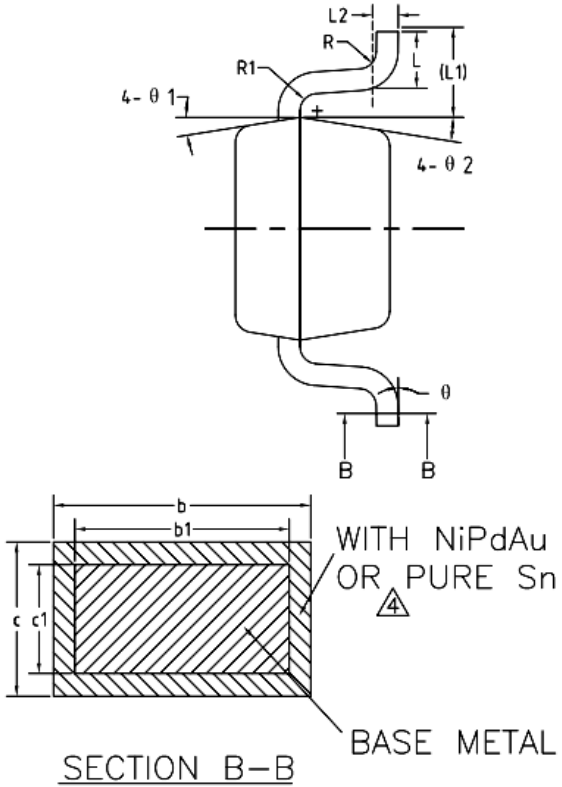
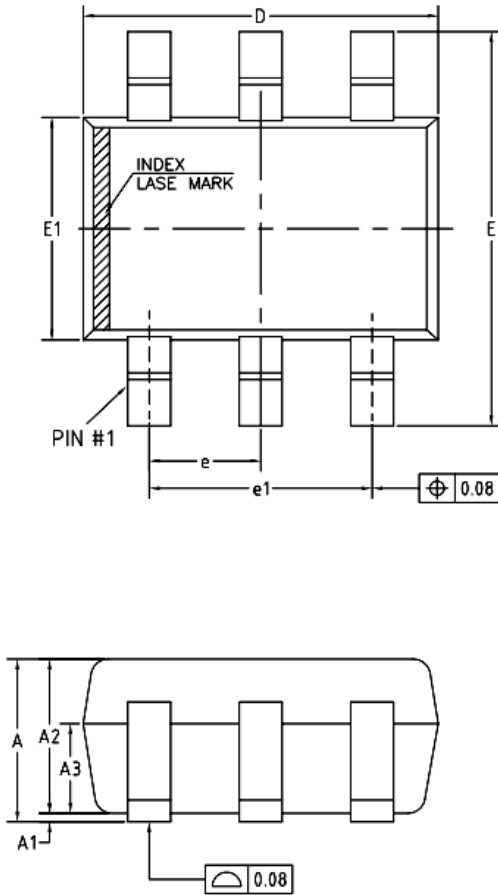

COMMON DIMENSIONS
(UNITS OF MEASURE=MILLIMETER)

SYMBOL	MIN	NOM	MAX
A	0.85	—	1.05
A1	0	—	0.10
A2	0.80	0.90	1.00
A3	0.47	0.52	0.57
b	NiPdAu 0.22 PURE Sn 0.23	—	0.29 0.33
b1	0.22	0.25	0.28
c	NiPdAu 0.115 PURE Sn 0.12	—	0.15 0.18
c1	0.115	0.13	0.14
D	2.02	2.07	2.12
E	2.20	2.30	2.40
E1	1.25	1.30	1.35
e	0.60	0.65	0.70
e1	1.20	1.30	1.40
L	0.28	0.33	0.38
L1	0.50REF		
L2	0.15BSC		
R	0.10	—	—
R1	0.10	—	0.25
theta	0°	—	8°
theta 1	6°	9°	12°
theta 2	6°	9°	12°

SOT23-6

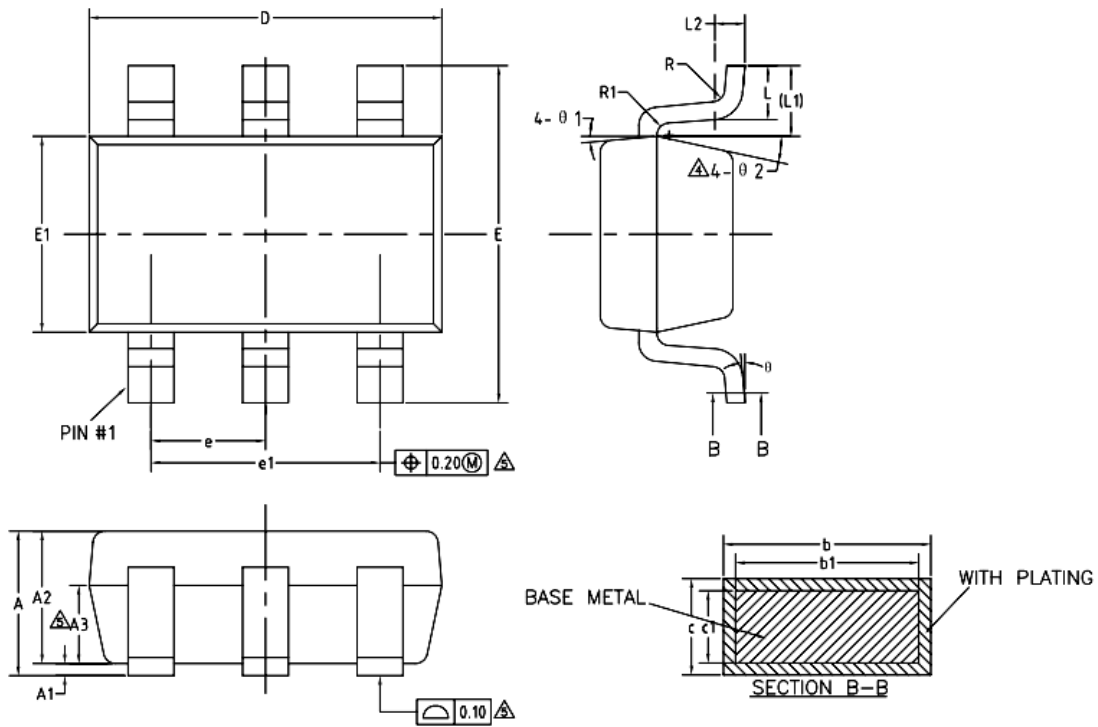

COMMON DIMENSIONS
(UNITS OF MEASURE=MILLIMETER)

SYMBOL	MIN	NOM	MAX
A	—	—	1.25
A1	0	—	0.15
A2	1.00	1.10	1.20
A3	0.60	0.65	0.70
b	0.36	—	0.50
b1	0.36	0.38	0.45
c	0.14	—	0.20
c1	0.14	0.15	0.16
D	2.826	2.926	3.026
E	2.60	2.80	3.00
E1	1.526	1.626	1.726
e	0.90	0.95	1.00
e1	1.80	1.90	2.00
L	0.35	0.45	0.60
L1	0.59REF		
L2	0.25BSC		
R	0.10	—	—
R1	0.10	—	0.20
θ	0°	—	8°
$\theta 1$	3°	5°	7°
$\theta 2$	6°	—	14°

DFN6

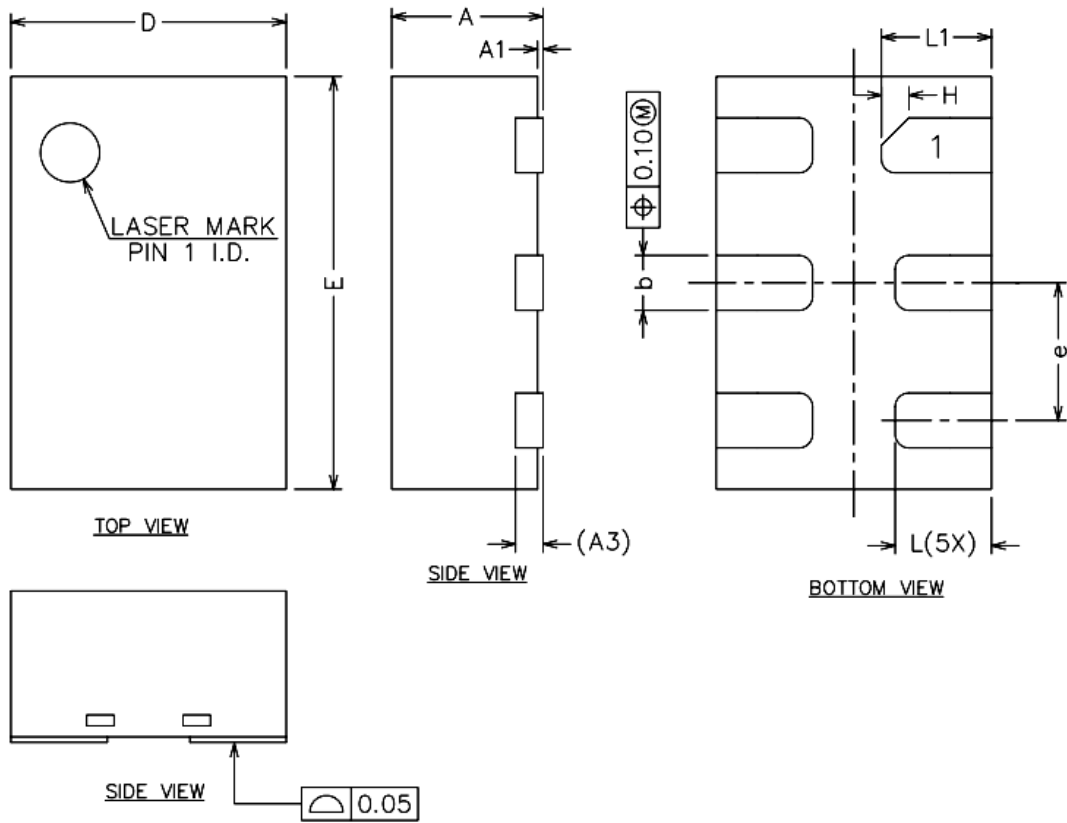

COMMON DIMENSIONS
(UNITS OF MEASURE=MILLIMETER)

SYMBOL	MIN	NOM	MAX
A	0.50	—	0.60
A1	0.00	0.02	0.05
A3	0.10REF		
b	0.15	0.20	0.25
D	0.90	1.00	1.10
E	1.40	1.50	1.60
e	0.40	0.50	0.60
H	0.10REF		
L	0.30	0.35	0.40
L1	0.35	0.40	0.45

Ordering information

Order code	Marking code	Package	Baseqty	Deliverymode
UMW SN74LVC2G07DBVR	C075	SOT23-6	3000	Tape and reel
UMW SN74LVC2G07DCKR	CV5	SC70-6	3000	Tape and reel
UMW SN74LVC2G07DRYR	CV	DFN6	3000	Tape and reel

X-ON Electronics

Largest Supplier of Electrical and Electronic Components

Click to view similar products for [Buffers & Line Drivers](#) category:

Click to view products by [Youtai](#) manufacturer:

Other Similar products are found below :

[LXV200-024SW](#) [74AUP2G34FW3-7](#) [HEF4043BP](#) [NL17SG125DFT2G](#) [NLU1GT126CMUTCG](#) [CD4041UBE](#) [54FCT240CTDB](#)
[74HCT540N](#) [DS14C88N](#) [070519XB](#) [NL17SZ07P5T5G](#) [74LVC2G17FW4-7](#) [CD4502BE](#) [5962-8982101PA](#) [61446R00](#) [NL17SH17P5T5G](#)
[NLV37WZ17USG](#) [74HCT126T14-13](#) [74VHC9126FT\(BJ\)](#) [RHRXH162244K1](#) [74AUP1G34FW5-7](#) [74AUP1G07FW5-7](#) [74LVC1G126FW4-7](#)
[74LVC2G126RA3-7](#) [74LVCE1G125FZ4-7](#) [54FCT240TLB](#) [NLX3G16DMUTCG](#) [NLX2G06AMUTCG](#) [LE87100NQCT](#) [LE87285NQC](#)
[LE87290YQC](#) [LE87290YQCT](#) [74AUP1G125FW5-7](#) [NLU2G16CMUTCG](#) [MC74LCX244MN2TWG](#) [NL17SG17P5T5G](#)
[NLV74HC125ADR2G](#) [NLVHCT245ADTR2G](#) [NLVVHC1G126DFT2G](#) [EL5623IRZ](#) [ISL15102AIRZ-T13](#) [ISL1539IRZ-T13](#)
[MC100EP17MNG](#) [MC74HCT365ADR2G](#) [MC74LCX244ADTR2G](#) [NL27WZ126US](#) [NL37WZ16US](#) [NLU1G07MUTCG](#) [NLU2G07MUTCG](#)
[NLX3G17BMX1TCG](#)