

Adjustable Precision Shunt Regulator

◆ Description

The TL431 is a three-terminal adjustable regulator series with a guaranteed thermal stability over applicable temperature ranges. The output voltage may be set to any value between V_{ref} and 36 volts with two external resistors. These device have a typical dynamic output impedance of 0.27Ω , Active output circuitry provides a very sharp turn-on characteristic, making these devices excellent replacement for zener diodes in many applications.

◆ Features

- Programmable Output Voltage to 36V. ➤
- Low Dynamic Output Impedance :
TL431xx: $0.27\ \Omega$ (Typical).
- Sink Current Capability of 0.1mA to 100mA.
- Equivalent Full-Range Temperature Coefficient of 50 ppm/°C
- Temperature Compensated for Operation over Full Rated Operating Temperature Range.
- Low Output Noise Voltage.
- Fast Turn on Responds.
- SOT-23, TO-92, SOT-89, SOP-8, TO-92L packages

◆ Symbol

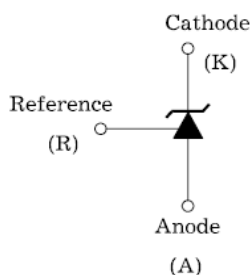

◆ Applications

- Precision Voltage Reference
- Linear Regulator
- Adjustable Power Supply
- Switching Power Supply
- Graphic Card
- Adapter

◆ Pin Description

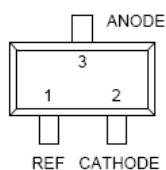

SOT-23 (Top View)

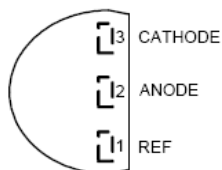

TO-92 (Top View)

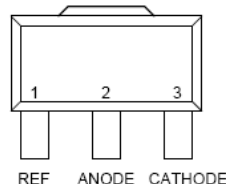

SOT-89 (Top View)

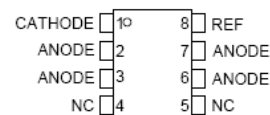

SOP-8 (Top View)

◆ **Absolute Maximum Ratings**

Symbol	Parameter		Value	Unit
V_{KA}	Cathode Voltage	TL431x	40	V
I_K	Cathode Current Range(Continuous)		-100~150	mA
I_{REF}	Reference Input Current Range		0.05~10	mA
$T_{oper.}$	Operating Temperature Range	TL431x	-40~85	°C
T_J	Junction Temperature Range		150	°C
T_{stg}	Storage Temperature Range		-65~+150	°C

◆ **Thermal Characteristics**

Symbol	Parameter	Package	Typical Value	Unit
θ_{JA}	Thermal Resistance From Junction to Ambient in Free Air. (Measured with the component mounted on a high effective thermal conductivity test board in free air.)	SOT-23	400	°C/W
		TO-92	400	
		SOT-89	400	
		SOP-8	450	

◆ **Recommended Operating Conditions**

Symbol	Characteristic		Min.	Typ.	Max.	Unit
V_{KA}	Cathode Voltage	TL431x	V_{REF}	-	36	V
I_K	Cathode Current	TL431x	0.5	-	100	mA

◆ Electrical Characteristics

($T_a=25\text{ }^\circ\text{C}$, $V_{KA}=V_{REF}$, $I_K=10\text{mA}$ unless otherwise noted .)

Symbol	Parameter		Test Condition	Min.	Typ.	Max.	Unit
V_{REF}	Reference input Voltage		$V_{KA}=V_{REF}$, $I_K=10\text{mA}$ 0.5%	2.483	2.495	2.508	V
$V_{REF(dev)}$	Deviation of Reference Input Voltage Over Full Temperature Range		$T_{min} \leq T_a \leq T_{max}$	-	3	17	mV
$\frac{\Delta V_{REF}}{\Delta V_{KA}}$	Ratio of change in Reference input Voltage to the Change in Cathode Voltage		$\Delta V_{KA}=10\text{V}-V_{REF}$	-0.4	-	2.7	mV/ V
			$\Delta V_{KA}=36\text{V}-10\text{V}$	-0.4	-	2.0	
I_{REF}	Reference Input Current		$R_1=10\text{K}\Omega$, $R_2=\infty$	-	1.8	4	μA
$I_{REF(dev)}$	Deviation of Reference Input Current Over Full Temperature Range		$R_1=10\text{K}\Omega$, $R_2=\infty$	-	0.4	1.2	μA
$I_{K(min)}$	Minimum Cathode Current for Regulation			-	0.25	0.5	mA
$I_{K(off)}$	Off-State Cathode Current		$V_{KA}=40\text{V}$, $V_{REF}=0$	-	0.17	0.9	μA
Z_{KA}	Dynamic Impedance	TL431xx	$I_K=1\text{mA}$ to 100mA $f \leq 1.0\text{KHz}$	-	0.27	0.5	Ω

◆ Test Circuit

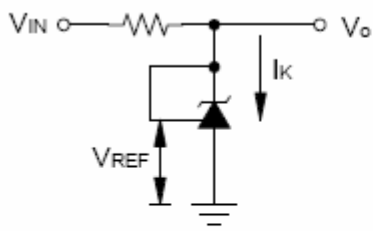

Figure 1. Test Circuit for $V_{KA} = V_{REF}$, $V_O = V_{KA} = V_{REF}$

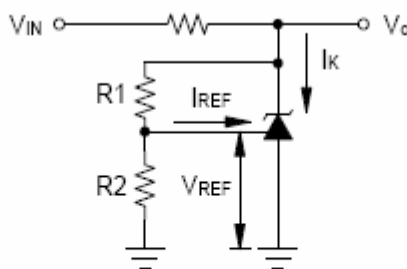

Figure 2. Test Circuit for $V_{KA} > V_{REF}$, $V_O = V_{KA} = V_{REF} \times (1 + R_1/R_2) + I_{REF} \times R_1$

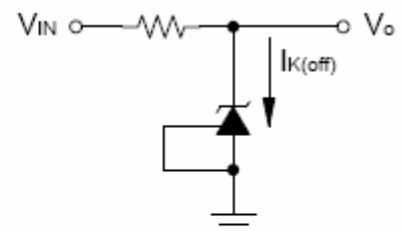
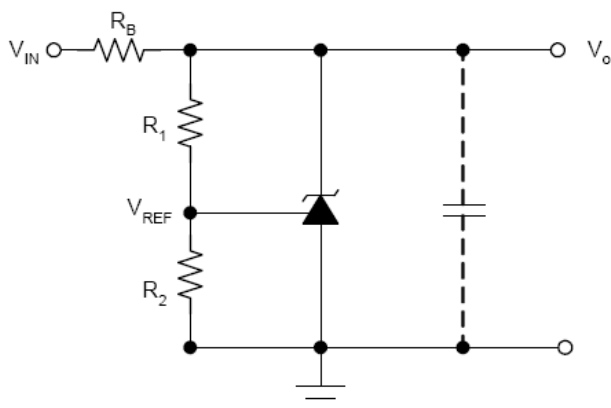
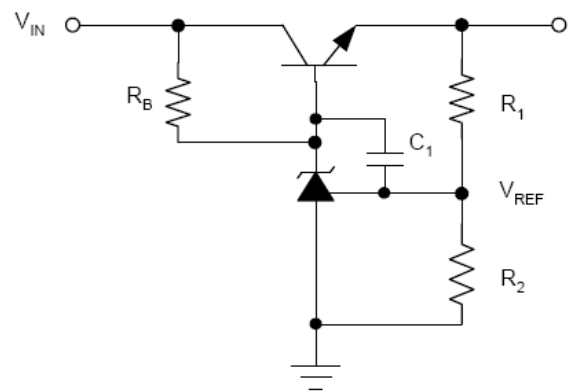

Figure 3. Test Circuit for $I_{K(off)}$

◆ Typical Application Circuits



Precision Voltage Reference



Precision High-Current Series Regulator

Notes for Typical Application Circuits:

1. For the series regulator applications, add a compensation capacitor C_1 between CATHODE and REF is strongly recommended to improve the stability of output voltage.
2. Set V_o according to the following equation: $V_o = V_{REF}(1 + R_1/R_2) + I_{REF} \times R_1$.
3. Choose the Value for R_B as below:
 - (1). The maximum limit for R_B should be such that the cathode current (I_K) is greater than the minimum operating current (0.5mA) at $V_{IN(MIN)}$.
 - (2). The minimum limit for R_B should be such that the cathode current (I_K) does not exceed 100mA under all load conditions, and the instantaneous turn-on value for I_K does not exceed 120mA.

◆ Typical Characteristics

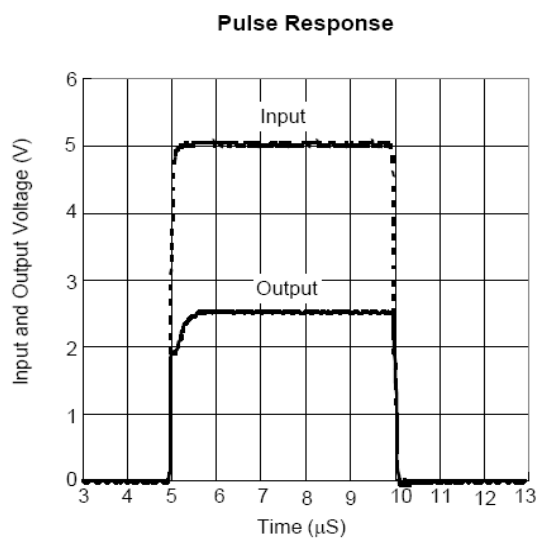
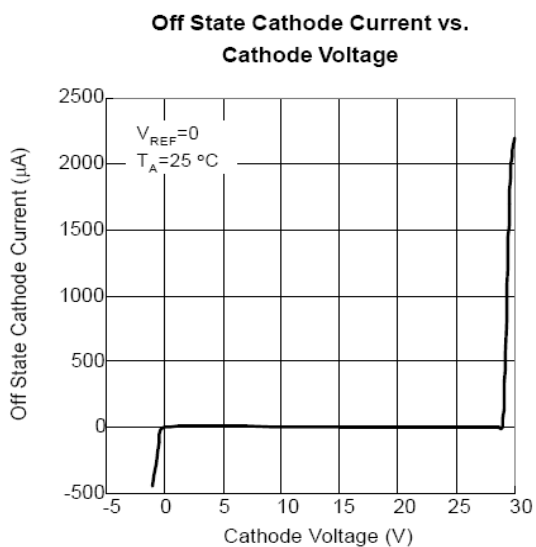
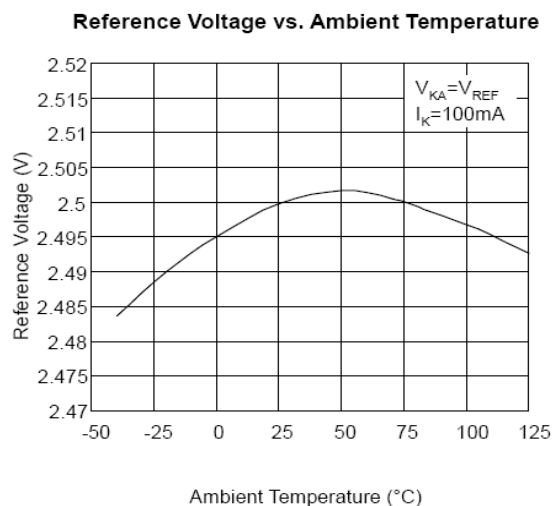
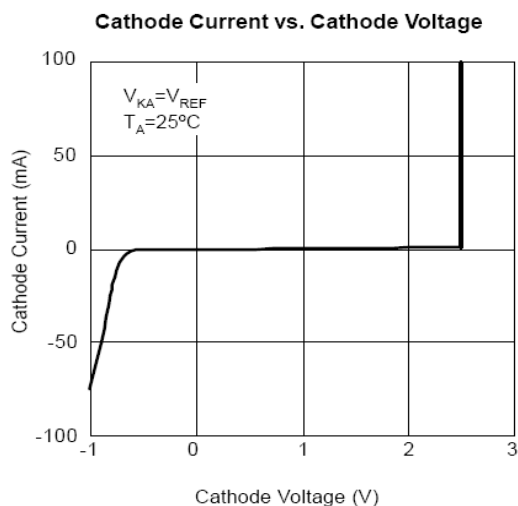
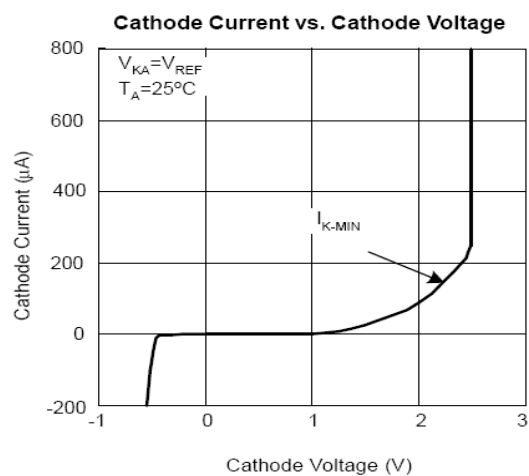
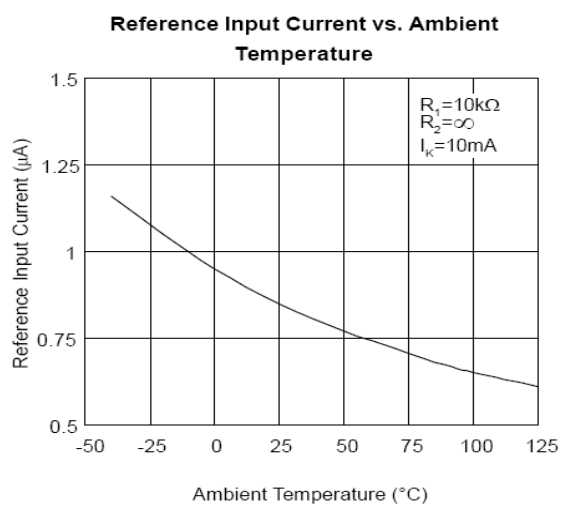

◆ Typical Characteristics (Continued)

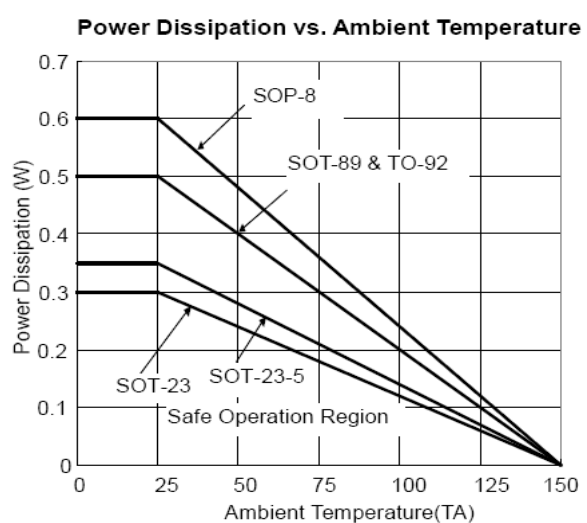
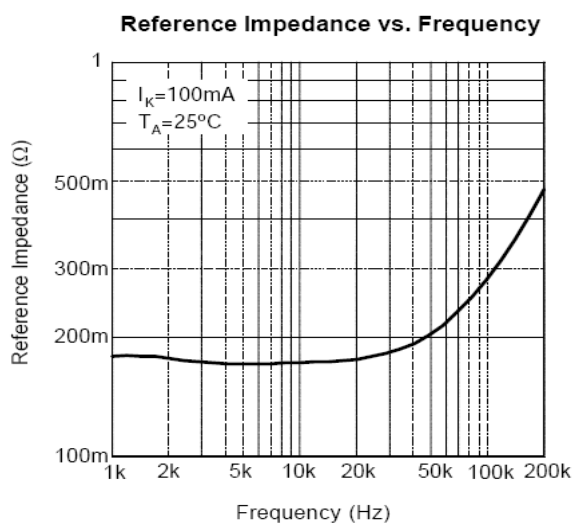
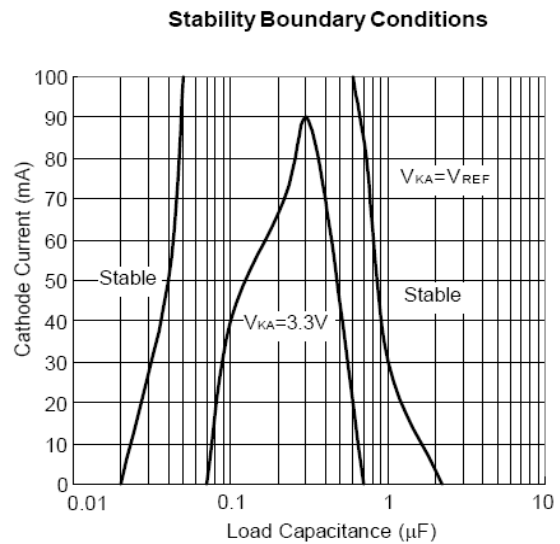
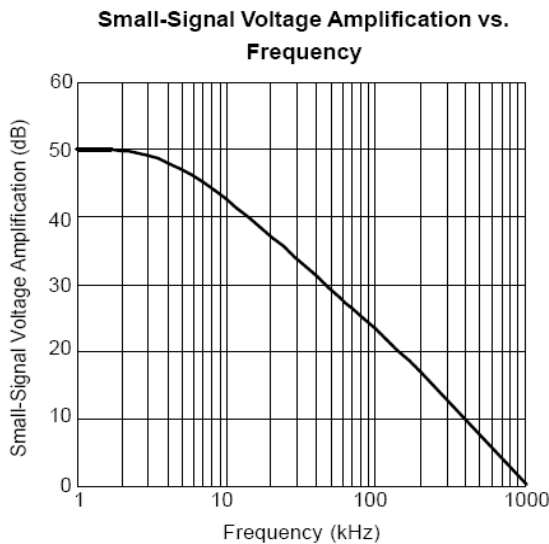
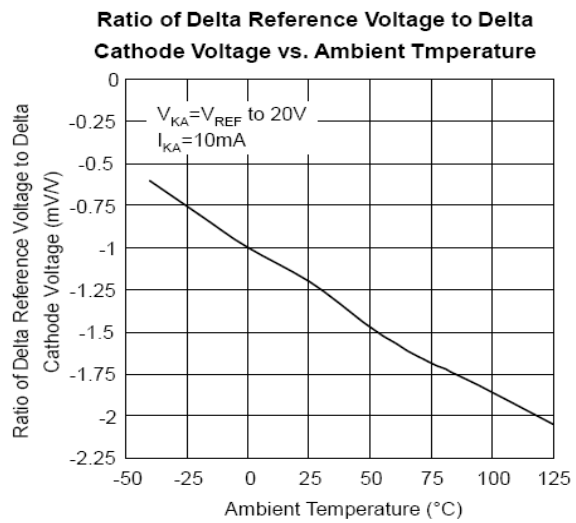
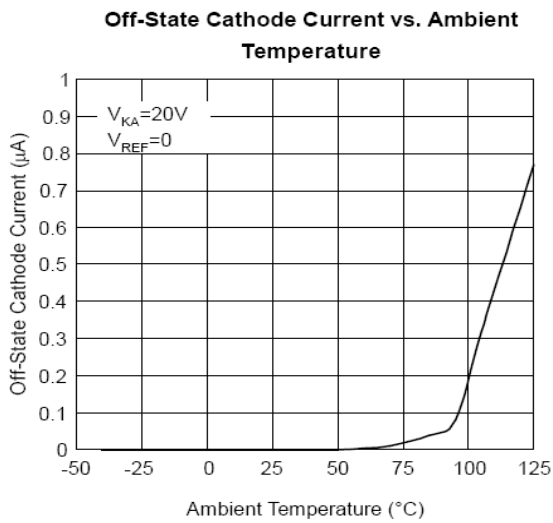

◆ Typical Characteristics (Continued)

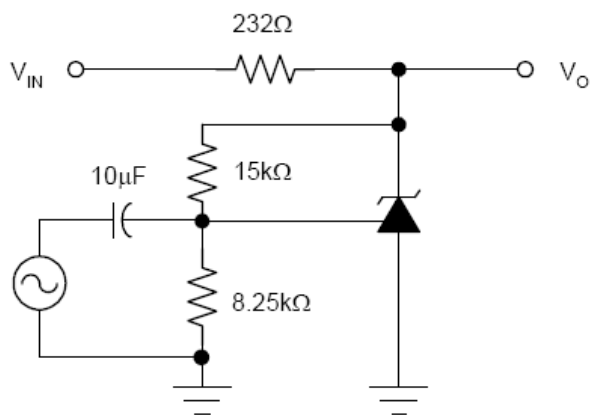

Voltage Amplification Test Circuit

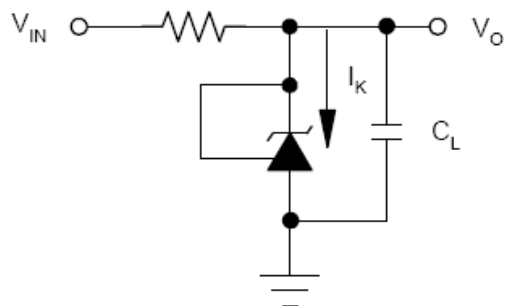

Stability Test Circuit for $V_{KA} = V_{REF}$

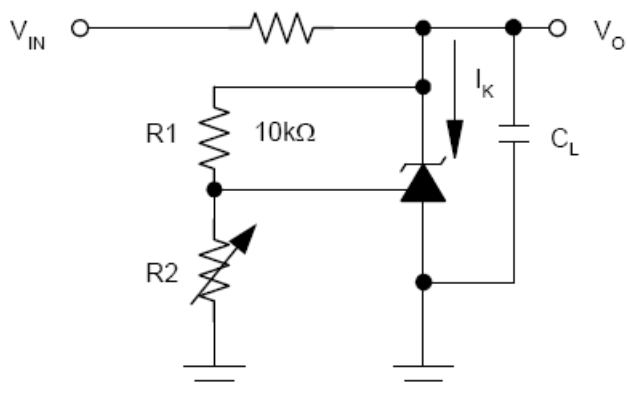

Stability Test Circuit for $V_{KA} > V_{REF}$
 $V_O = V_{KA} = V_{REF} \times (1 + R1/R2) + I_{REF} \times R1$
 Use the MLCC for C_L

◆ Package Information

SOT-23

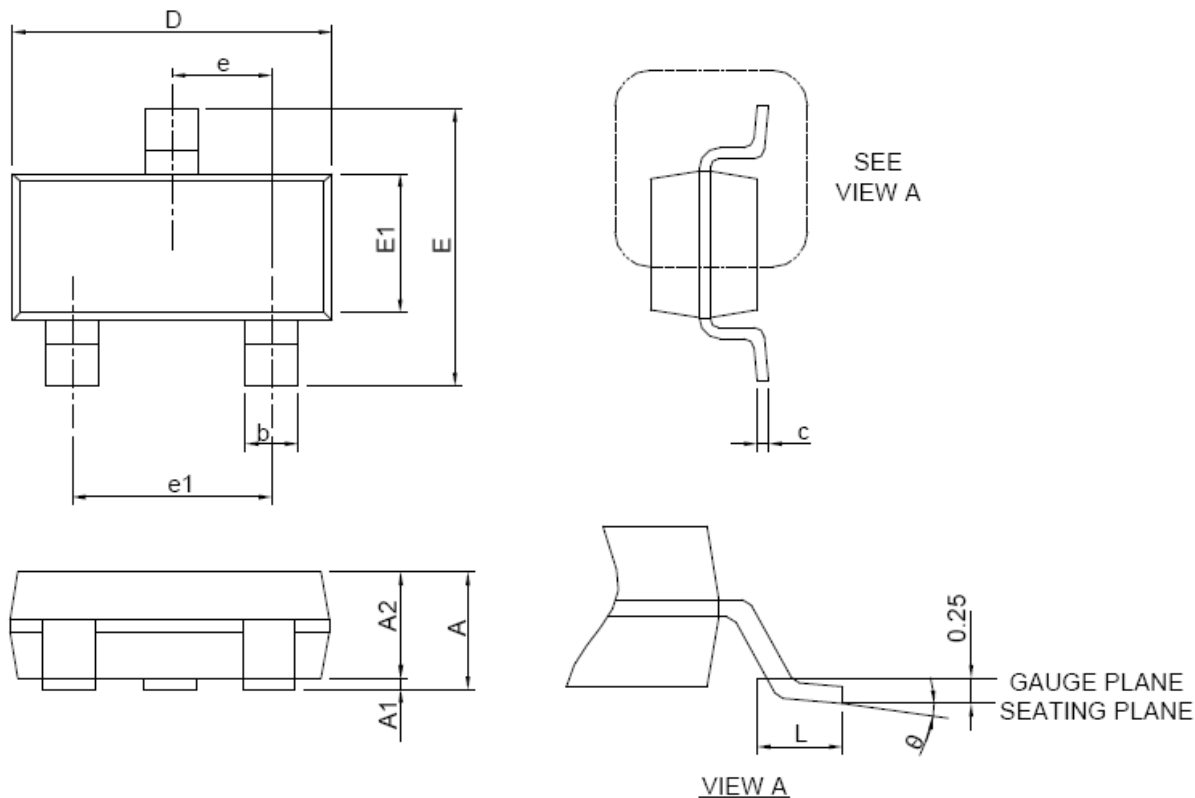

SYMBOL	SOT-23			
	MILLIMETERS		INCHES	
	MIN.	MAX.	MIN.	MAX.
A		1.15		0.045
A1	0.00	0.10	0.000	0.004
A2	0.90	1.05	0.035	0.041
b	0.30	0.50	0.012	0.020
c	0.08	0.15	0.003	0.006
D	2.70	3.00	0.110	0.118
E	2.25	2.55	0.089	0.100
E1	1.20	1.40	0.047	0.055
e	0.95 BSC		0.037 BSC	
e1	1.90 BSC		0.075 BSC	
L	0.30	0.60	0.012	0.024
θ	0°	8°	0°	8°

◆ Package Information

TO-92

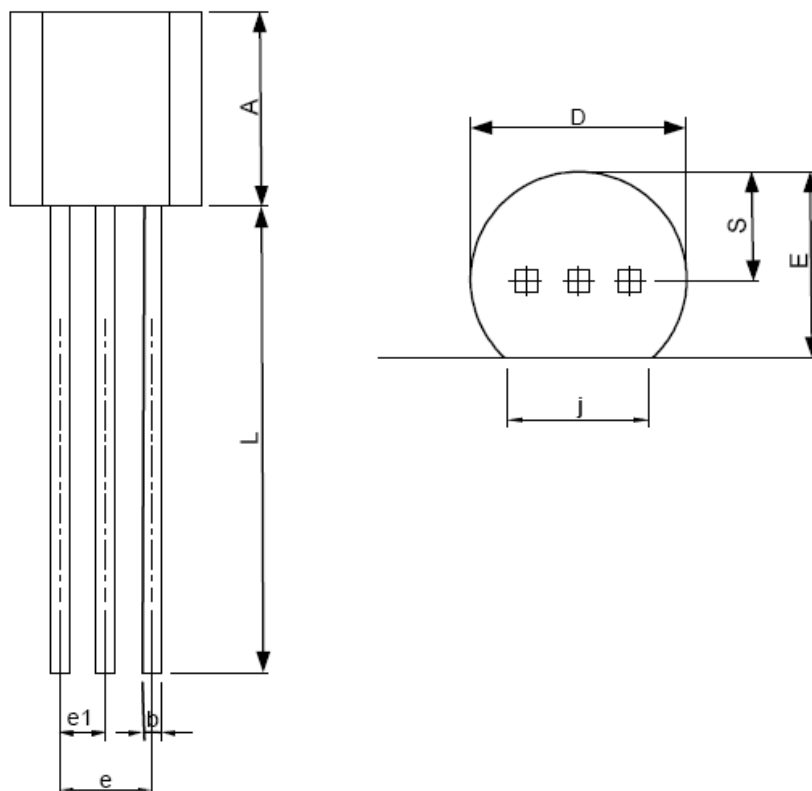

SYMBOL	TO-92			
	MILLIMETERS		INCHES	
	MIN.	MAX.	MIN.	MAX.
A	4.32	5.33	0.170	0.210
b	0.41	0.53	0.016	0.021
D	4.45	5.20	0.175	0.205
E	3.18	4.19	0.125	0.165
e	2.42	2.66	0.095	0.105
e1	1.15	1.39	0.045	0.055
j	3.43	4.00	0.135	0.157
L	12.70	15.00	0.500	0.591
S	2.03	2.66	0.080	0.105

Note : Follow JEDEC TO-92.

◆ Package Information

SOT-89

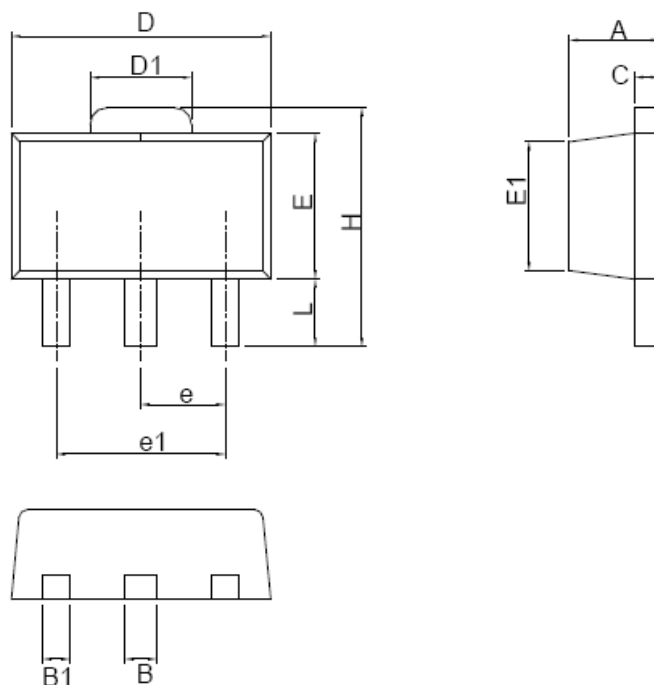

SYMBOL	SOT-89			
	MILLIMETERS		INCHES	
	MIN.	MAX.	MIN.	MAX.
A	1.40	1.60	0.055	0.063
B	0.44	0.56	0.017	0.022
B1	0.36	0.48	0.014	0.019
C	0.35	0.44	0.014	0.017
D	4.40	4.60	0.173	0.181
D1	1.62	1.83	0.064	0.072
E	2.29	2.60	0.090	0.102
E1	2.13	2.29	0.084	0.090
e	1.50 BSC		0.059 BSC	
e1	3.00 BSC		0.118 BSC	
H	3.94	4.25	0.155	0.167
L	0.89	1.20	0.035	0.047

Note : Follow JEDEC TO-243 AA.

◆ Package Information

SOP-8

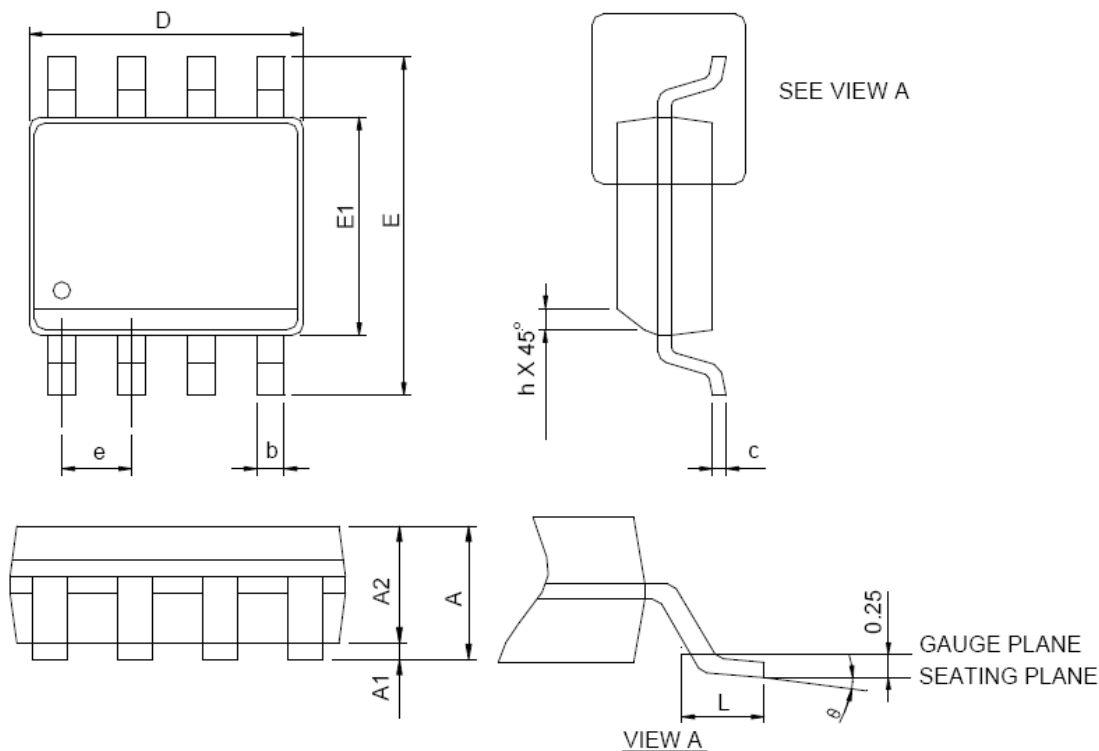

SYMBOL	SOP-8			
	MILLIMETERS		INCHES	
	MIN.	MAX.	MIN.	MAX.
A		1.75		0.069
A1	0.10	0.25	0.004	0.010
A2	1.25		0.049	
b	0.31	0.51	0.012	0.020
c	0.17	0.25	0.007	0.010
D	4.80	5.00	0.189	0.197
E	5.80	6.20	0.228	0.244
E1	3.80	4.00	0.150	0.157
e	1.27 BSC		0.050 BSC	
h	0.25	0.50	0.010	0.020
L	0.40	1.27	0.016	0.050
θ	0°	8°	0°	8°

- Note: 1. Follow JEDEC MS-012 AA.
 2. Dimension "D" does not include mold flash, protrusions or gate burrs. Mold flash, protrusion or gate burrs shall not exceed 6 mil per side.
 3. Dimension "E" does not include inter-lead flash or protrusions. Inter-lead flash and protrusions shall not exceed 10 mil per side.

◆ Package Information

TO-92L

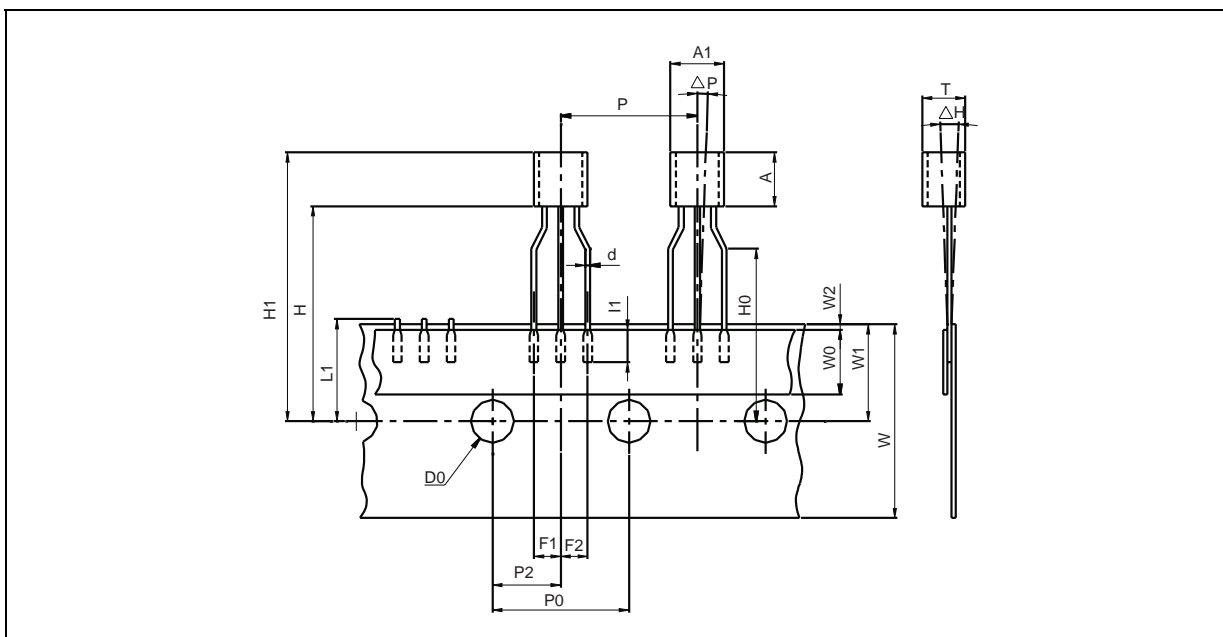

Dim.	Millimeters			Inches		
	Min	Typ.	Max.	Min.	Typ.	Max.
AL			5.0			0.197
A			5.0			0.197
T			4.0			0.157
d		0.45			0.018	
I1	2.5			0.098		
P	11.7	12.7	13.7	0.461	0.500	0.539
PO	12.4	12.7	13	0.488	0.500	0.512
P2	5.95	6.35	6.75	0.234	0.250	0.266
F1/F2	2.4	2.5	2.8	0.094	0.098	0.110
Δh	-1	0	1	-0.039	0	0.039
ΔP	-1	0	1	-0.039	0	0.039
W	17.5	18.0	19.0	0.689	0.709	0.748
W0	5.7	6	6.3	0.224	0.236	0.248
W1	8.5	9	9.75	0.335	0.354	0.384
W2			0.5			0.020
H			20			0.787
H0	15.5	16	16.5	0.610	0.630	0.650
H1			25			0.984
DO	3.8	4.0	4.2	0.150	0.157	0.165
L1			11			0.433

◆ Ordering information

Order Code	Package	Baseqty	Deliverymode	Accuracy
UMW TL431AL	TO-92L	2000	Ammo outfit	0.5%
UMW TL431L	TO-92	1000	Bulk Bag	0.5%
UMW TL431	SOT-23	3000	Tape and Reel	0.5%
UMW TL431S	SOT-89	1000	Tape and Reel	0.5%
UMW TL431D	SOP-8	2500	Tape and Reel	0.5%

X-ON Electronics

Largest Supplier of Electrical and Electronic Components

Click to view similar products for [Voltage References](#) category:

Click to view products by [Youtai](#) manufacturer:

Other Similar products are found below :

[5962-8686103XC](#) [LT1460GIZ-5PBF](#) [LT1009IZPBF](#) [NCV431BVDMR2G](#) [REF01J/883](#) [SC431ILPRAG](#) [AP432AQG-7](#) [LM4040B25QFTA](#)
[TL431BL3T](#) [BR431M](#) [MC1403BM/TR](#) [HT431BRZ](#) [ME4315AM6G-2](#) [ME4315AM6G-1](#) [TL431A-YK](#) [TL431](#) [TL431-1](#) [TL431](#) [TL431](#)
[XC6206P332MR](#) [HT431CRZ](#) [LM285M-1.2/TR](#) [S-LR431AKLT1G](#) [LR431AKLT1G](#) [LTL432ATLT1G](#) [TL431](#) [TP431CS3-1](#)
[LTL431APTSLT1G](#) [TP431CS3](#) [TL432](#) [TPR3530-S3TR](#) [LM236M-5.0/TR](#) [HT431ARZ](#) [TL431ACZ](#) [KA431SLMF2TF](#) [KA431SMF2TF](#)
[KA431SMFTF](#) [LM4040QCEM3-3.0/NOPB](#) [LM4041C12ILPR](#) [LM4050AIM3X-5.0/NOPB](#) [LM4120AIM5-2.5/NOP](#) [LM431SCCMFX](#)
[ZXRE250BSA-7](#) [ZXRE125DN8TA](#) [TS3330AQPR](#) [ZXRE250ASA-7](#) [ZTL431ASE5TA](#) [REF3012AIDBZR](#) [LM385BM-2.5/NOPB](#) [LM385D-](#)
[2.5R2G](#)