

Description

The TSV6390, TSV6391, and their "A" versions are single operational amplifiers (op amps) offering low voltage, low power operation, and rail-to-rail input and output.

With a very low input bias current and low offset voltage (500 μ V maximum for the A version), the TSV6390 and TSV6391 are ideal for applications requiring precision. The devices can operate at power supplies ranging from 1.5 to 5.5 V, and are therefore ideal for battery-powered devices, extending battery life.

When used with a gain (above -3 or 4), these products feature an excellent speed/power consumption ratio, offering a 2.4 MHz gain bandwidth product while consuming only 60 μ A at a 5 V supply voltage.

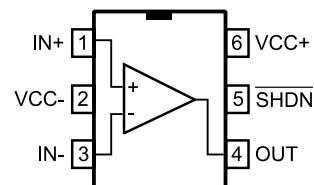

TSV6390ICT/ILT
SC70-6/SOT23-6

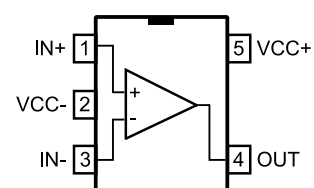

TSV6391ICT/ILT
SC70-5/SOT23-5

Features

- Low offset voltage: 500 μ V max (A version)
- Low power consumption: 60 μ A typ at 5 V
- Low supply voltage: 1.5 V – 5.5 V
- Gain bandwidth product: 2.4 MHz typical
- Stable in gain configuration (-3 or 4)
- Low power shutdown mode: 5 nA typical
- High output current: 63 mA at $V_{CC} = 5$ V
- Low input bias current: 1 pA typical
- Rail-to-rail input and output
- Extended temperature range:
-40 $^{\circ}$ C to 125 $^{\circ}$ C
- 4 kV human body model

Applications

- Battery-powered applications
- Portable devices
- Signal conditioning
- Active filtering
- Medical instrumentation

Absolute maximum ratings and operating conditions

Table 1: Absolute maximum ratings (AMR)

Symbol	Parameter	Value	Unit	
V_{CC}	Supply voltage ⁽¹⁾	6	V	
V_{id}	Differential input voltage ⁽²⁾	$\pm V_{CC}$		
V_{in}	Input voltage ⁽³⁾	$(V_{CC-}) - 0.2$ to $(V_{CC+}) + 0.2$		
I_{in}	Input current ⁽⁴⁾	10	mA	
\overline{SHDN}	Shutdown voltage ⁽³⁾	$(V_{CC-}) - 0.2$ to $(V_{CC+}) + 0.2$	V	
T_{stg}	Storage temperature	-65 to 150	°C	
T_j	Maximum junction temperature	150		
R_{thja}	Thermal resistance junction to ambient ⁽⁵⁾⁽⁶⁾	SC70-6	232	°C/W
		SOT23-6	240	
		SC70-5	205	
		SOT23-5	250	
ESD	HBM: human body model ⁽⁷⁾	4	kV	
	MM: machine model ⁽⁸⁾	300	V	
	CDM: charged device model ⁽⁹⁾	1.5	kV	
	Latch-up immunity	200	mA	

Notes:

- ⁽¹⁾ All voltage values, except the differential voltage, are with respect to network ground terminal.
- ⁽²⁾ The differential voltage is the non-inverting input terminal with respect to the inverting input terminal.
- ⁽³⁾ $V_{CC-} - V_{in}$ must not exceed 6 V, V_{in} must not exceed 6 V.
- ⁽⁴⁾ Input current must be limited by a resistor in series with the inputs.
- ⁽⁵⁾ R_{th} are typical values.
- ⁽⁶⁾ Short-circuits can cause excessive heating and destructive dissipation.
- ⁽⁷⁾ Human body model: 100 pF discharged through a 1.5 k Ω resistor between two pins of the device, done for all couples of pin combinations with other pins floating.
- ⁽⁸⁾ Machine model: a 200 pF capacitor is charged to the specified voltage, then discharged directly between two pins of the device with no external series resistor (internal resistor < 5 Ω), done for all couples of pin combinations with other pins floating.
- ⁽⁹⁾ Charged device model: all pins plus package are charged together to the specified voltage and then discharged directly to the ground.

Table 2: Operating conditions

Symbol	Parameter	Value	Unit
V_{CC}	Supply voltage	1.5 to 5.5	V
V_{icm}	Common mode input voltage range	$(V_{CC-}) - 0.1$ to $(V_{CC+}) + 0.1$	
T_{oper}	Operating free air temperature range	-40 to 125	°C

Electrical characteristics

Table 3: Electrical characteristics at VCC+ = 1.8 V with VCC- = 0 V, Vicm = VCC/2, Tamb = 25 °C and RL connected to VCC/2 (unless otherwise specified)

Symbol	Parameter	Conditions	Min.	Typ.	Max.	Unit
DC performance						
V _{io}	Offset voltage	TSV6390 and TSV6391			3	mV
		TSV6390A and TSV6391A			0.5	
		T _{min} < T _{op} < T _{max} , TSV6390 and TSV6391			4.5	
		T _{min} < T _{op} < T _{max} , TSV6390A and TSV6391A			2	
$\Delta V_{io}/\Delta T$	Input offset voltage drift			2		μ V/°C
I _{io}	Input offset current, V _{out} = V _{CC} /2 ⁽¹⁾			1	10	pA
		T _{min} < T _{op} < T _{max}		1	100	
I _{ib}	Input bias current, (V _{out} = V _{CC} /2) ⁽¹⁾			1	10	pA
		T _{min} < T _{op} < T _{max}		1	100	
CMR	Common mode rejection ratio 20 log ($\Delta V_{io}/\Delta V_{ic}$)	0 V to 1.8 V, V _{out} = 0.9 V	53	74		dB
		T _{min} < T _{op} < T _{max}	51			
A _{vd}	Large signal voltage gain	R _L = 10 k Ω , V _{out} = 0.5 V to 1.3 V	85	95		dB
		T _{min} < T _{op} < T _{max}	80			
V _{OH}	High-level output voltage	R _L = 10 k Ω		5	35	mV
		T _{min} < T _{op} < T _{max}			50	
V _{OL}	Low-level output voltage	R _L = 10 k Ω		4	35	mV
		T _{min} < T _{op} < T _{max}			50	
I _{out}	I _{sink}	V _{out} = 1.8 V	6	12		mA
		T _{min} < T _{op} < T _{max}	4			
	I _{source}	V _{out} = 0 V	6	10		
		T _{min} < T _{op} < T _{max}	4			
I _{CC}	Supply current, $\overline{\text{SHDN}} = V_{CC}$	No load, V _{out} = V _{CC} /2	40	50	60	μ A
		T _{min} < T _{op} < T _{max}			62	
AC performance						
GBP	Gain bandwidth product	R _L = 10 k Ω , C _L = 100 pF		2		MHz
Gain	Minimum gain for stability	Phase margin = 60°, R _f = 10 k Ω , R _L = 10 k Ω , C _L = 20 pF		4		V/V
				-3		
SR	Slew rate	R _L = 10 k Ω , C _L = 100 pF, V _{out} = 0.5 V to 1.3 V		0.7		V/ μ s
e _n	Equivalent input noise voltage	f = 1 kHz		60		nV/ \sqrt Hz
		f = 10 kHz		33		

Symbol	Parameter	Conditions	Min.	Typ.	Max.	Unit
DC performance						
I_{CC}	Supply current in shutdown mode (all operators)	$\overline{SHDN} = V_{CC-}$		2.5	50	nA
		$T_{min} < T_{op} < 85\text{ }^{\circ}\text{C}$			200	
		$T_{min} < T_{op} < 125\text{ }^{\circ}\text{C}$				1.5
t_{on}	Amplifier turn-on time	$R_L = 2\text{ k}\Omega, V_{out} = (V_{CC-}) \text{ to } (V_{CC-}) + 0.2\text{ V}$		300		ns
t_{off}	Amplifier turn-off time	$R_L = 2\text{ k}\Omega, V_{out} = (V_{CC+}) - 0.5\text{ V to } (V_{CC+}) - 0.7\text{ V}$		20		
V_{IH}	\overline{SHDN} logic high		1.3			V
V_{IL}	\overline{SHDN} logic low				0.5	
I_{IH}	\overline{SHDN} current high	$\overline{SHDN} = V_{CC+}$		10		pA
I_{IL}	\overline{SHDN} current low	$\overline{SHDN} = V_{CC-}$		10		
I_{OLeak}	Output leakage in shutdown mode	$\overline{SHDN} = V_{CC-}$		50		nA
		$T_{min} < T_{op} < T_{max}$		1		

Micropower (60 μ A), wide bandwidth (2.4 MHz) CMOS operational amplifiers

Table 5: $V_{CC+} = 3.3$ V, $V_{CC-} = 0$ V, $V_{icm} = V_{CC}/2$, $T_{amb} = 25$ °C, R_L connected to $V_{CC}/2$ (unless otherwise specified)

Symbol	Parameter	Conditions	Min.	Typ.	Max.	Unit
DC performance						
V_{io}	Offset voltage	TSV6390 and TSV6391			3	mV
		TSV6390A and TSV6391A			0.5	
		$T_{min} < T_{op} < T_{max}$, TSV6390 and TSV6391			4.5	
		$T_{min} < T_{op} < T_{max}$, TSV6390A and TSV6391A			2	
$\Delta V_{io}/\Delta T$	Input offset voltage drift			2		μ V/°C
I_{io}	Input offset current ⁽¹⁾			1	10	pA
		$T_{min} < T_{op} < T_{max}$		1	100	
I_{ib}	Input bias current ⁽¹⁾			1	10	pA
		$T_{min} < T_{op} < T_{max}$		1	100	
CMR	Common mode rejection ratio $20 \log (\Delta V_{ic}/\Delta V_{io})$	0 V to 3.3 V, $V_{out} = 1.65$ V	57	79		dB
		$T_{min} < T_{op} < T_{max}$	53			
A_{vd}	Large signal voltage gain	$R_L = 10$ k Ω , $V_{out} = 0.5$ V to 2.8 V	88	98		dB
		$T_{min} < T_{op} < T_{max}$	83			
V_{OH}	High-level output voltage	$R_L = 10$ k Ω		6	35	mV
		$T_{min} < T_{op} < T_{max}$			50	
V_{OL}	Low-level output voltage	$R_L = 10$ k Ω		7	35	mV
		$T_{min} < T_{op} < T_{max}$			50	
I_{out}	I_{sink}	$V_{out} = 3.3$ V	23	45		mA
		$T_{min} < T_{op} < T_{max}$	20	42		
	I_{source}	$V_{out} = 0$ V	23	38		
		$T_{min} < T_{op} < T_{max}$	20			
I_{CC}	Supply current, $\overline{SHDN} = V_{CC}$	No load, $V_{out} = V_{CC}/2$	43	55	64	μ A
		$T_{min} < T_{op} < T_{max}$			66	
AC performance						
GBP	Gain bandwidth product	$R_L = 10$ k Ω , $C_L = 100$ pF		2.2		MHz
Gain	Minimum gain for stability	Phase margin = 60°, $R_f = 10$ k Ω , $R_L = 10$ k Ω , $C_L = 20$ pF,		4		V/V
				-3		
SR	Slew rate	$R_L = 10$ k Ω , $C_L = 100$ pF, $V_{out} = 0.5$ V to 2.8 V		0.9		V/ μ s
e_n	Equivalent input noise voltage	$f = 1$ kHz		65		nV/ \sqrt Hz

Micropower (60 μ A), wide bandwidth (2.4 MHz) CMOS operational amplifiers

Table 6: Electrical characteristics at VCC+ = 5 V with VCC- = 0 V, Vicm = VCC/2, Tamb = 25 °C and RL connected to VCC/2 (unless otherwise specified)

Symbol	Parameter	Conditions	Min.	Typ.	Max.	Unit
DC performance						
V _{io}	Offset voltage	TSV6390 and TSV6391			3	mV
		TSV6390A and TSV6391A			0.5	
		T _{min} < T _{op} < T _{max} , TSV6390 and TSV6391			4.5	
		T _{min} < T _{op} < T _{max} , TSV6390A and TSV6391A			2	
$\Delta V_{io}/\Delta T$	Input offset voltage drift			2		μ V/°C
I _{io}	Input offset current, V _{out} = V _{CC} /2 ⁽¹⁾			1	10	pA
		T _{min} < T _{op} < T _{max}		1	100	
I _{ib}	Input bias current, V _{out} = V _{CC} /2 ⁽¹⁾			1	10	pA
		T _{min} < T _{op} < T _{max}		1	100	
CMR	Common mode rejection ratio 20 log ($\Delta V_{ic}/\Delta V_{io}$)	0 V to 5 V, V _{out} = 2.5 V	60	80		dB
		T _{min} < T _{op} < T _{max}	55			
SVR	Supply voltage rejection ratio 20 log ($\Delta V_{CC}/\Delta V_{io}$)	V _{CC} = 1.8 to 5 V	75	93		dB
		T _{min} < T _{op} < T _{max}	73			
A _{vd}	Large signal voltage gain	R _L = 10 k Ω , V _{out} = 0.5 V to 4.5 V	89	98		
		T _{min} < T _{op} < T _{max}	84			
V _{OH}	High-level output voltage	R _L = 10 k Ω		7	35	mV
		T _{min} < T _{op} < T _{max}			50	
V _{OL}	Low-level output voltage	R _L = 10 k Ω		6	35	mV
		T _{min} < T _{op} < T _{max}			50	
I _{out}	I _{sink}	V _{out} = 5 V	40	65		mA
		T _{min} < T _{op} < T _{max}	35			
	I _{source}	V _{out} = 0 V	40	72		
		T _{min} < T _{op} < T _{max}	35			
I _{CC}	Supply current, $\overline{SHDN} = V_{CC}$	No load, V _{out} = V _{CC} /2	50	60	69	μ A
		T _{min} < T _{op} < T _{max}			72	
AC performance						
GBP	Gain bandwidth product	R _L = 10 k Ω , C _L = 100 pF		2.4		MHz
Gain	Minimum gain for stability	Phase margin = 60°, R _f = 10 k Ω , R _L = 10 k Ω , C _L = 20 pF,		4		V/V
				-3		
SR	Slew rate	R _L = 10 k Ω , C _L = 100 pF		1.1		V/ μ s
e _n	Equivalent input noise voltage	f = 1 kHz		60		nV/ \sqrt Hz
		f = 10 kHz		33		
THD+N	Total harmonic distortion + noise	A _v = -10, f _{in} = 1 kHz, R = 100 k Ω , V _{icm} = V _{CC} /2, V _{in} = 40 mV _{pp}		0.11		%

Electrical characteristics curves

Figure 1: Supply current vs. supply voltage at $V_{icm} = V_{CC}/2$

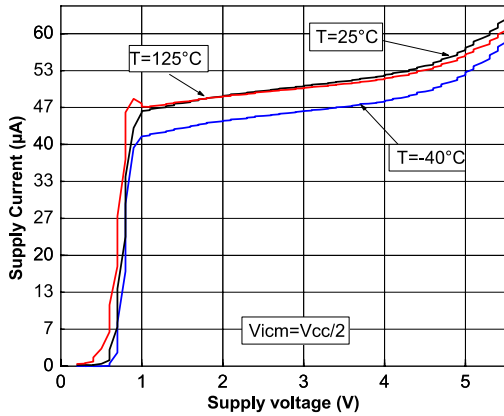

Figure 2: Output current vs. output voltage at $V_{CC} = 1.5$ V

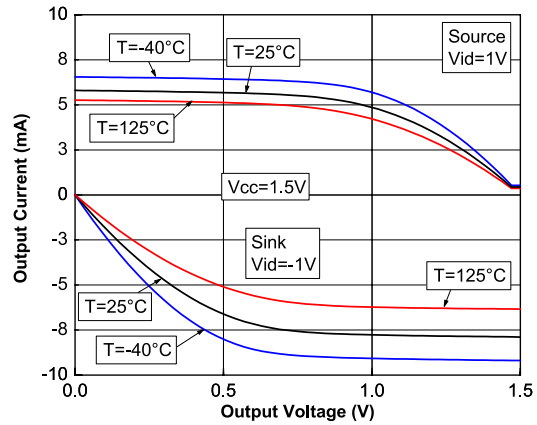

Figure 3: Output current vs. output voltage at $V_{CC} = 5$ V

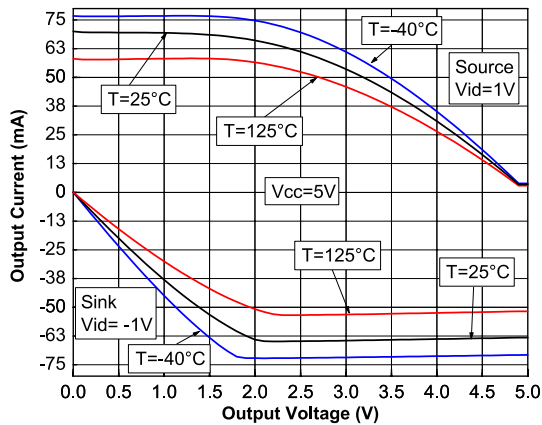

Figure 4: Peaking at closed loop gain = -10

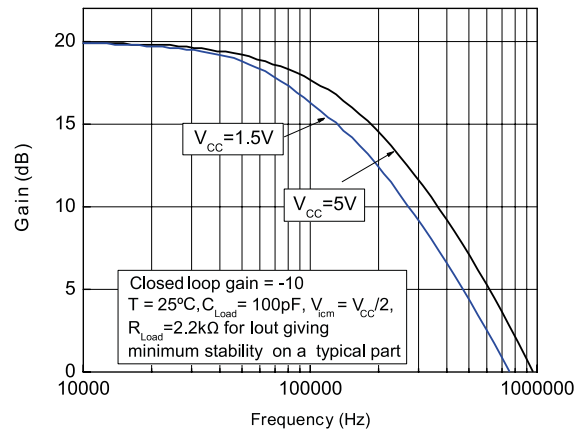

Figure 5: Peaking at closed loop gain = -3 at $V_{CC} = 1.5$ V

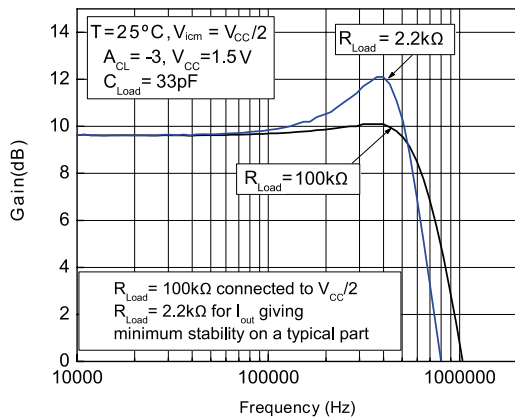

Figure 6: Peaking at closed loop gain = -3 at $V_{CC} = 5$ V

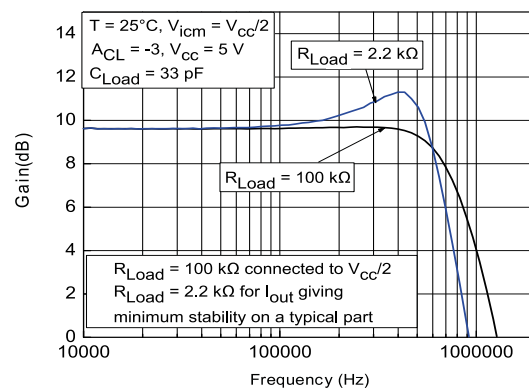

Figure 7: Positive slew rate vs. supply voltage

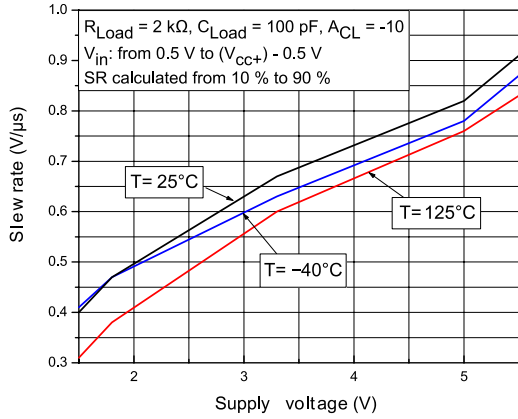

Figure 8: Negative slew rate vs. supply voltage

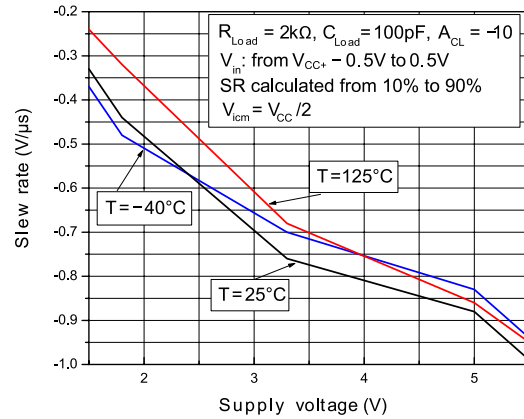

Figure 9: Distortion + noise vs. output voltage at VCC = 1.8 V

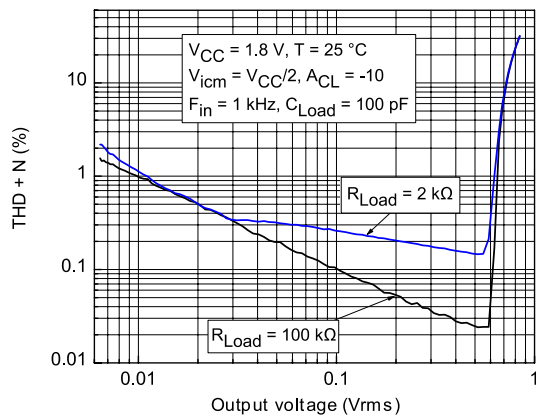

Figure 10: Distortion + noise vs. output voltage at VCC = 5 V

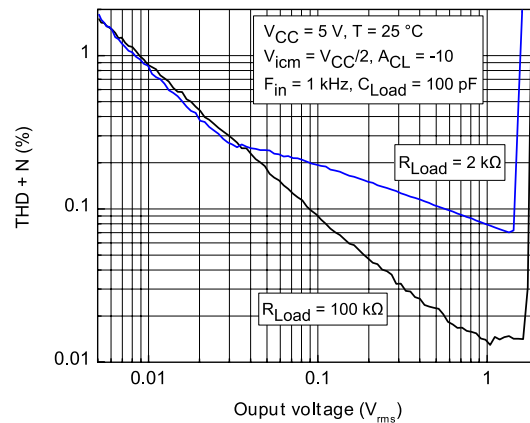

Figure 11: Slew rate timing

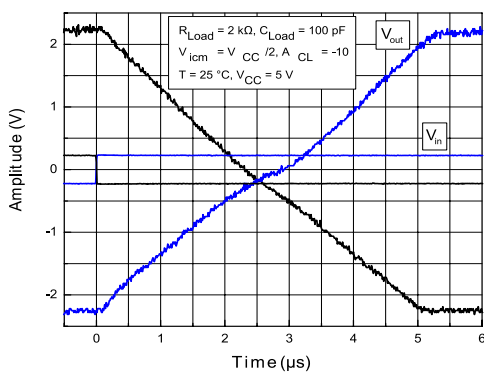

Figure 12: Noise vs. frequency at VCC = 5 V

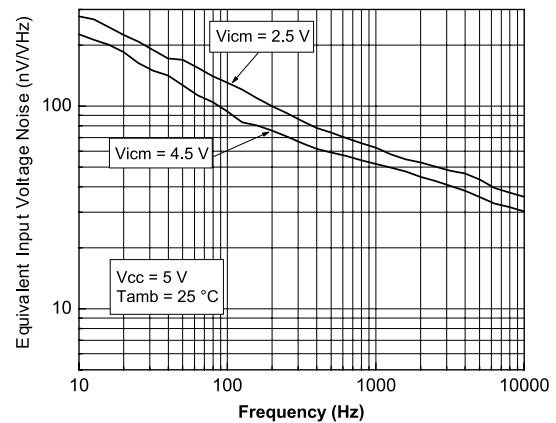

Figure 13: Input offset voltage vs input common-mode at $V_{CC} = 1.5$ V

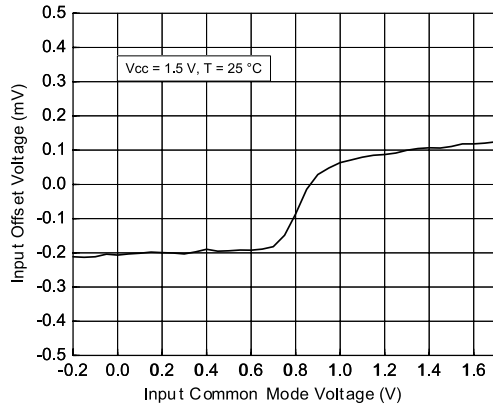

Figure 14: Input offset voltage vs input common-mode at $V_{CC} = 5$ V

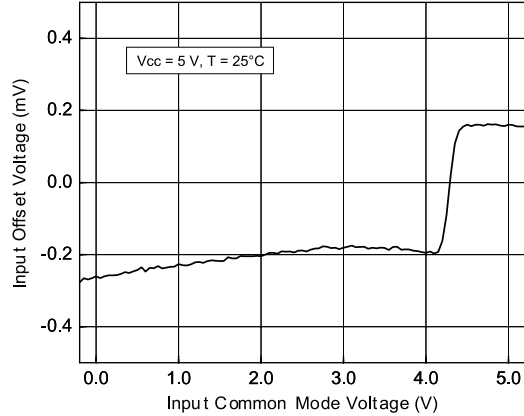

Figure 15: Test configuration for turn-on time (V_{out} pulled down)

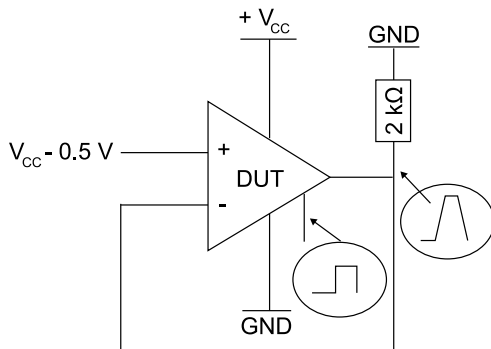

Figure 16: Test configuration for turn-off time (V_{out} pulled down)

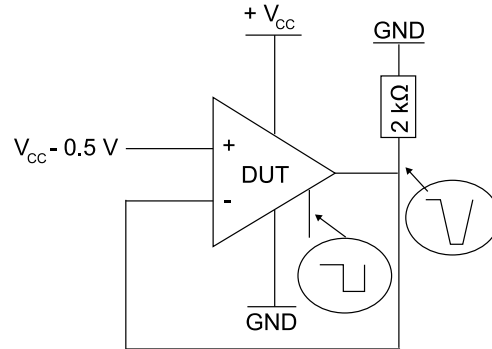

Figure 17: Turn-on time, $V_{CC} = 5$ V, V_{out} pulled down, $T = 25$ °C

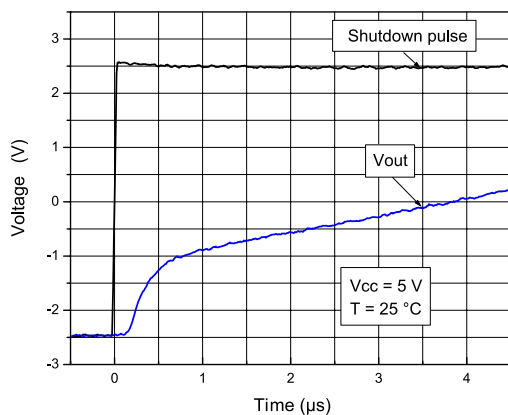
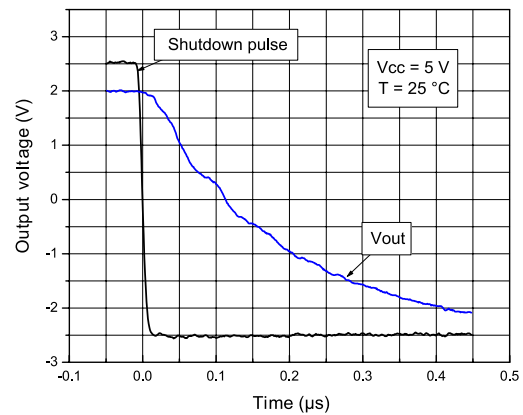
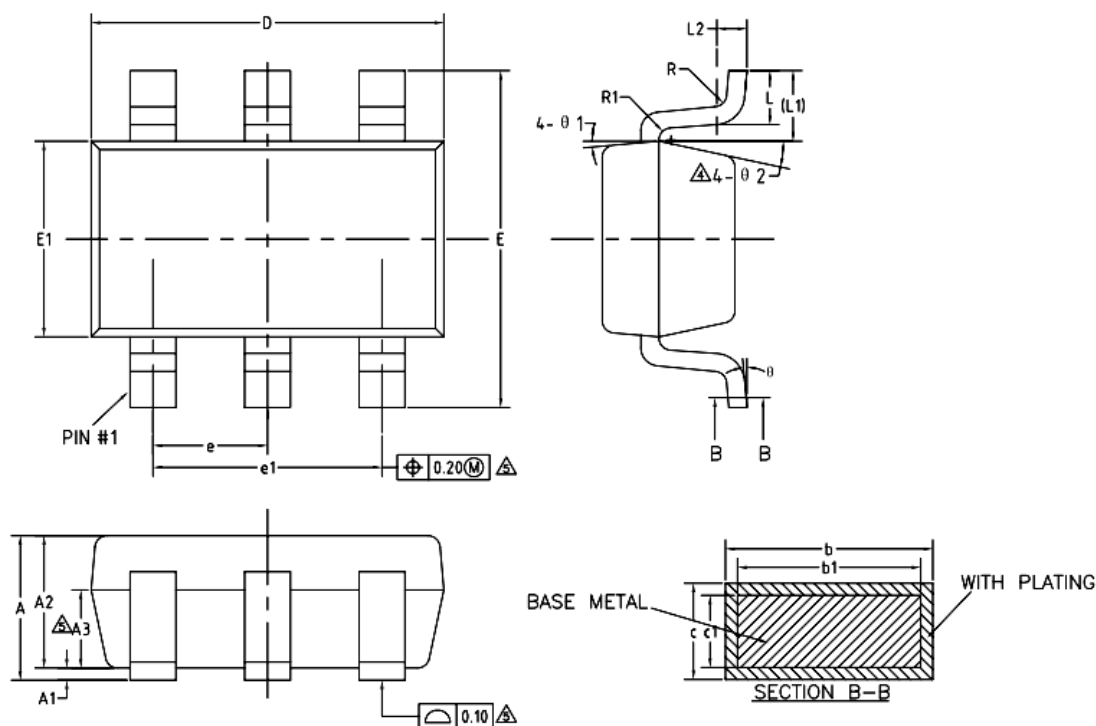

Figure 18: Turn-off time, $V_{CC} = 5$ V, V_{out} pulled down, $T = 25$ °C



Package Dimension

SOT23-6



COMMON DIMENSIONS
(UNITS OF MEASURE=MILLIMETER)

SYMBOL	MIN	NOM	MAX
A	—	—	1.25
A1	0	—	0.15
A2	1.00	1.10	1.20
A3	0.60	0.65	0.70
b	0.36	—	0.50
b1	0.36	0.38	0.45
c	0.14	—	0.20
c1	0.14	0.15	0.16
D	2.826	2.926	3.026
E	2.60	2.80	3.00
E1	1.526	1.626	1.726
e	0.90	0.95	1.00
e1	1.80	1.90	2.00
L	0.35	0.45	0.60
L1	0.59REF		
L2	0.25BSC		
R	0.10	—	—
R1	0.10	—	0.20
θ	0°	—	8°
$\theta 1$	3°	5°	7°
$\theta 2$	6°	—	14°

SC70-5 (SOT353)

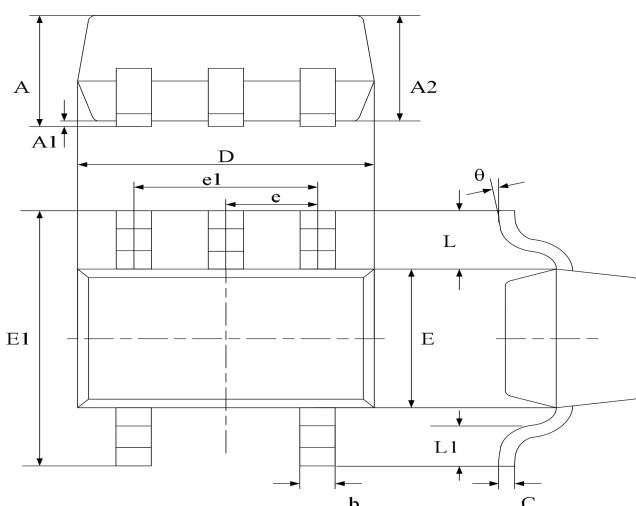

Symbol	Dimensions In Millimeters		Dimensions In Inches	
	Min	Max	Min	Max
A	0.800	1.100	0.035	0.043
A1	0.000	0.100	0.000	0.004
A2	0.800	0.900	0.035	0.039
b	0.150	0.350	0.006	0.014
C	0.080	0.150	0.003	0.006
D	1.8500	2.150	0.079	0.087
E	1.100	1.400	0.045	0.053
E1	1.950	2.200	0.085	0.096
e	0.850 typ.		0.026 typ.	
e1	1.200	1.400	0.047	0.055
L	0.42 ref.		0.021 ref.	
L1	0.260	0.460	0.010	0.018
θ	0°	8°	0°	8°

Ordering information

Order code	Package	Baseqty	Deliverymode	Marking
UMW TSV6391ICT	SC70-5	3000	Tape and reel	K41 U
UMW TSV6391AICT	SC70-5	3000	Tape and reel	K20 U
UMW TSV6390ILT	SOT23-6	3000	Tape and reel	K19 U
UMW TSV6390AILT	SOT23-6	3000	Tape and reel	K42 U

X-ON Electronics

Largest Supplier of Electrical and Electronic Components

Click to view similar products for [Operational Amplifiers - Op Amps](#) category:

Click to view products by [Youtai](#) manufacturer:

Other Similar products are found below :

[430227FB](#) [LT1678IS8](#) [NCV33202DMR2G](#) [NJM324E](#) [M38510/13101BPA](#) [NTE925](#) [AZV358MTR-G1](#) [AP4310AUMTR-AG1](#)
[AZV358MMTR-G1](#) [SCY33178DR2G](#) [NCV20034DR2G](#) [NTE778S](#) [NTE871](#) [NTE937](#) [NJU7057RB1-TE2](#) [SCY6358ADR2G](#)
[NJM2904CRB1-TE1](#) [UPC4570G2-E1-A](#) [UPC4741G2-E1-A](#) [UPC4574GR-9LG-E1-A](#) [NJM8532RB1-TE1](#) [EL2250CS](#) [EL5100IS](#) [EL5104IS](#)
[EL5127CY](#) [EL5127CYZ](#) [EL5133IW](#) [EL5152IS](#) [EL5156IS](#) [EL5162IS](#) [EL5202IY](#) [EL5203IY](#) [EL5204IY](#) [EL5210CS](#) [EL5210CYZ](#)
[EL5211IYE](#) [EL5220CY](#) [EL5223CLZ](#) [EL5223CR](#) [EL5224ILZ](#) [EL5227CLZ](#) [EL5227CRZ](#) [EL5244CS](#) [EL5246CS](#) [EL5246CSZ](#) [EL5250IY](#)
[EL5251IS](#) [EL5257IS](#) [EL5260IY](#) [EL5261IS](#)