

Single-Channel 4A Peak High-speed Low side Gate Driver

Description

The UCC27511DBVR single-channel, high-speed, low side gate-driver device can effectively drive MOSFET and IGBT power switches. The UCC27511DBVR are capable of sourcing and sinking high peak-current pulses into capacitive loads offering rail to rail drive capability and extremely small propagation delay.

Applications

- Switch-Mode Power Supplies
- DC-to-DC Converters
- Companion Gate-Driver Devices for Digital Power Controllers
- Solar Power, Motor Control, UPS
- GaN Gate Driver

Features

- Dual Input Design (Choice of an Inverting (IN- pin) or Non-inverting (IN+ pin) Driver Configuration)
 - Unused Input Pin Can Be Used for Enable or Disable Function
- TTL and CMOS Compatible Input-Logic Threshold
- 4.5 to 25-V Single-Supply Range
- Operating Temperature Range of -40 to 125°C
- -10 to 25-V Input Voltage Range
- Undervoltage Lockout
 - Undervoltage Lockout turn-on threshold 4.3V
 - Undervoltage Lockout turn-off threshold 4.1V
- Turn on/Turn off Delays:
 - Ton/Toff =30ns/30ns
- 4-A Peak Source and Sink-Drive Current

Pin Configuration

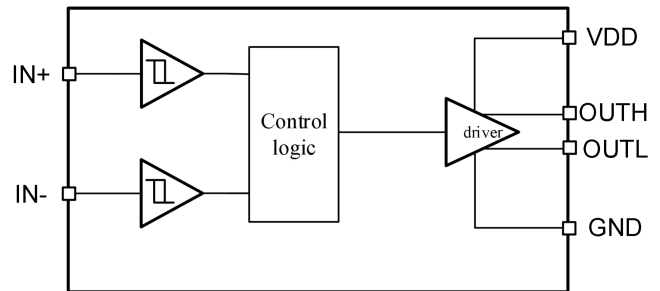

Single-Channel 4A Peak High-speed Low side Gate Driver

Pin Configuration and Functions

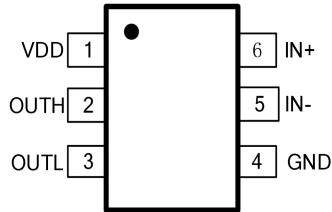

6-Pin SOT23 Package Top View

Pin Functions

PIN	NAME	DESCRIPTION
1	VDD	Bias supply input
2	OUTH	Sourcing current output of driver
3	OUTL	Sinking current output of driver
4	GND	Ground: All signals are referenced to this pin.
5	IN-	Inverting Input
6	IN+	Non-inverting Input

Single-Channel 4A Peak High-speed Low side Gate Driver

Absolute Maximum Ratings

Stresses beyond those listed under Absolute Maximum Ratings may cause permanent damage to the device. All voltages are with respect to GND unless otherwise noted, Currents are positive into, negative out of the specified terminal, environment temperature is 25 °C.

Symbol	Definition	MIN	MAX	UNIT
VDD	Supply voltage range	-0.3	25	V
V _{IN}	INA, INB voltage	-10	20	
ESD	Human body model (HBM)	-4000	4000	V
	Charged device model (CDM)	-1000	1000	V
P _D	SOT23 package power(TA ≤70 °C)	—	0.4	W
T _J	Operating junction temperature	-40	+140	°C
T _S	Storage temperature	-65	+150	
VDD	Supply voltage range	4.5	20	V
T _C	ambient temperature	-40	125	°C

Single-Channel 4A Peak High-speed Low side Gate Driver

Electrical Characteristics

VDD= 15V, -40°C≤TJ≤140°C (unless otherwise noted)

Symbol	Definition	MIN	TYP	MAX	UNIT
V _{IH}	Input signal high threshold	2.4	—	—	V
V _{IL}	Input signal low threshold	—	—	0.8	V
UVDDH	Undervoltage Lockout (UVLO) turn-on threshold VDD	—	4.3	—	V
UVDDL	Undervoltage Lockout (UVLO) turn-off threshold VDD	—	4.1	—	V
I _{IN}	Input current(0V≤V _{IN} ≤V _{CC})	—	—	200	μA
V _{OH}	High output voltage	V _{CC} -0.025	—	—	V
V _{OL}	Low output voltage	—	—	0.025	V
I _{PK+}	Peak output source current	—	4	—	A
I _{PK-}	Peak output sink current	—	4	—	A
t _R	Rise time(C _{LOAD} =1nF)	—	10	15	ns
t _F	Fall time(C _{LOAD} =1nF)	—	8	13	ns
t _{ON}	Turn-on propagation delay(C _{LOAD} =1nF)	—	30	50	ns
t _{OFF}	Turn-off propagation delay(C _{LOAD} =1nF)	—	30	50	ns
I _{Q1}	VDD quiescent supply current(V _{IN+} =0V, V _{IN-} =5V)	—	300	500	μA
I _{Q0}	VDD quiescent supply current(V _{IN+} =5V, V _{IN-} =0V)	—	300	500	μA

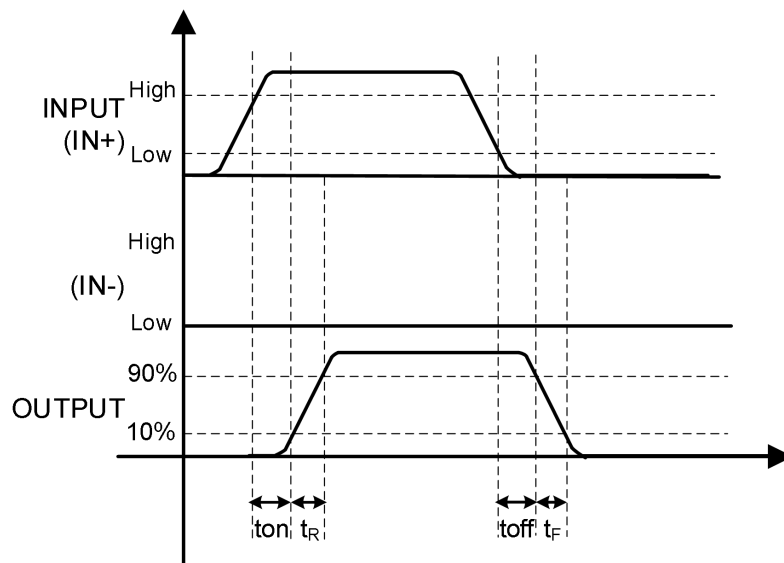

Figure 1 Input-Output waveform(non-inverting)

Single-Channel 4A Peak High-speed Low side Gate Driver

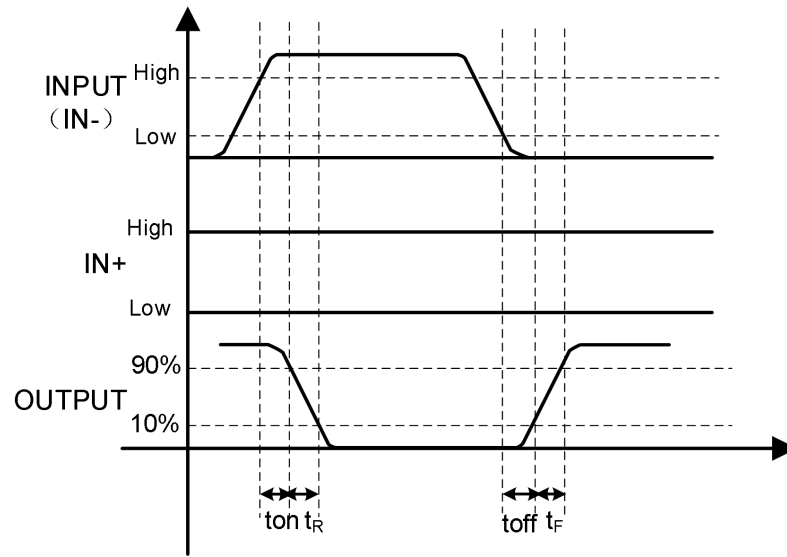
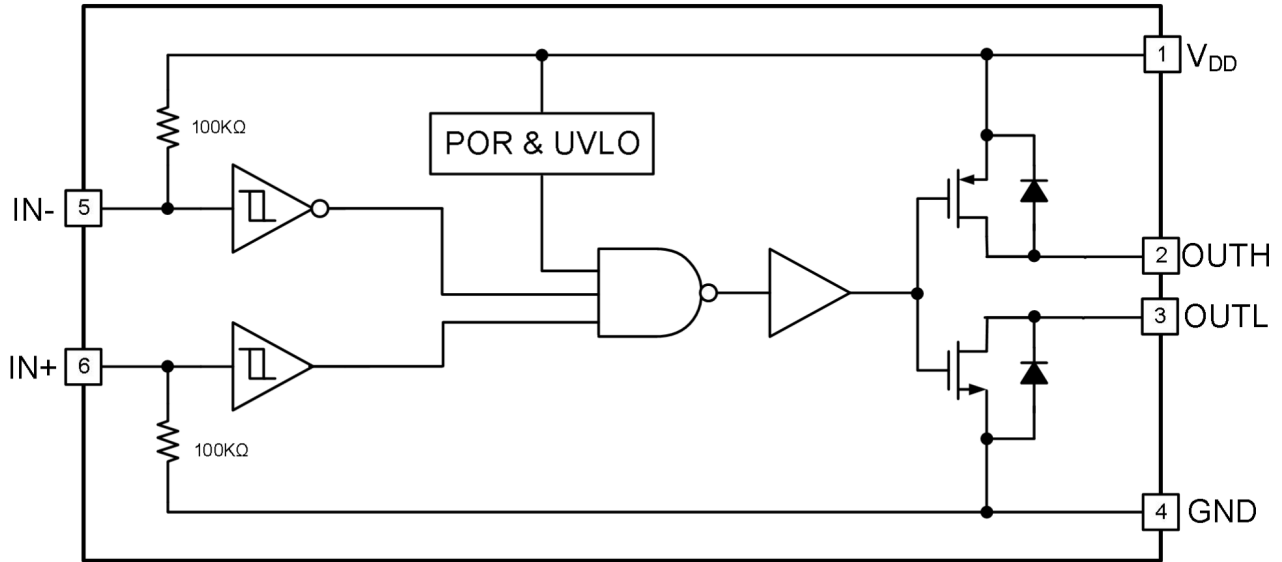

Figure 2 Input-Output waveform(inverting)

Detailed description



Typical Application

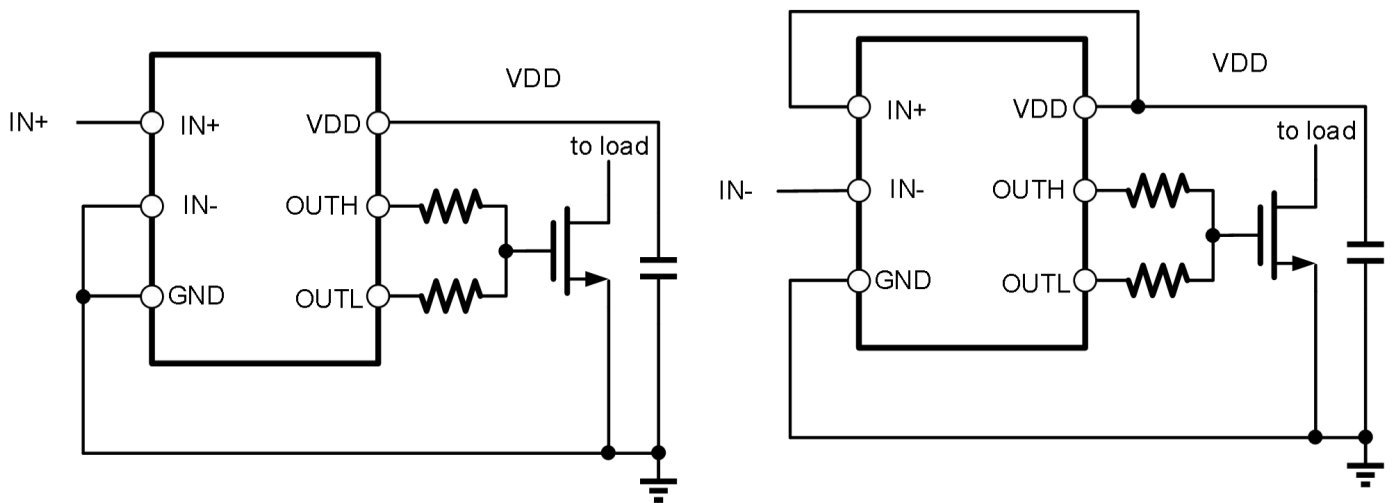

Figure 3 Typical Application Diagram of UCC27511DBVR

SOT23-6

Marking

Ordering information

Order code	Package	Base qty	Delivery mode
UMW UCC27511DBVR	SOT23-6	3000	Tape and reel

X-ON Electronics

Largest Supplier of Electrical and Electronic Components

Click to view similar products for [Gate Drivers](#) category:

Click to view products by [Youtai](#) manufacturer:

Other Similar products are found below :

[56956](#) [57.404.7355.5](#) [LT4936](#) [57.904.0755.0](#) [5811-0902](#) [0131700000](#) [LTP70N06](#) [LVP640](#) [5J0-1000LG-SIL](#) [LY2-US-AC240](#) [LY3-UA-DC24](#) [LZNQ2-US-DC12](#) [LZP40N10](#) [60100564](#) [60249-1-CUT-TAPE](#) [0134220000](#) [6035](#) [60713816](#) [61161-90](#) [6131-204-23149P](#) [6131-205-17149P](#) [6131-209-15149P](#) [6131-218-17149P](#) [6131-220-21149P](#) [6131-260-2358P](#) [6131-265-11149P](#) [CS1HCPU63](#) [6150-5001](#) [CSB4](#) [CSK-38-60006](#) [CSK-38-60008](#) [621A](#) [622-4053LF](#) [6273](#) [M40N08MA-H](#) [M55155/29XH06](#) [64-807](#) [65-1930-6](#) [CV500ISB02](#) [M83723/88Y1407N](#) [CWD012-2](#) [CWD03-3](#) [CX3225SB16934D0PPSC2](#) [CX5032GB10000D0PPS02](#) [687-772NF1](#) [70.140.1653](#) [70.200.0653.0](#) [703001B01F060](#) [70-3601](#) [706006D02F0601](#)