

Description

ULN2002D is a monolithic integrated high voltage withstand, high current Darlington array IC, with five independent Darlington drive channels inside the circuit. A freewheeling diode is designed inside the circuit, which can be used to drive inductive loads such as relays and stepping motors. Single Darlington

The tube collector can output 500 mA current, and multiple channels can be connected in parallel to achieve higher current output capacity. The circuit can be widely used in relay drive, lighting drive, display screen drive (LED), stepping motor drive and logic buffer.

Each Darlington tube of ULN2002D is connected in series with a 2.7K base resistance, which can be directly connected to the TTL/CMOS circuit under 5V working voltage, and can directly process the data that originally needed standard logic buffer to process.

Each Darlington tube input stage of ULN2002D is designed with a 4K pull-down resistance to ground, which can prevent the load misoperation caused by the uncertain state of the MCU.

Pin Arrangement

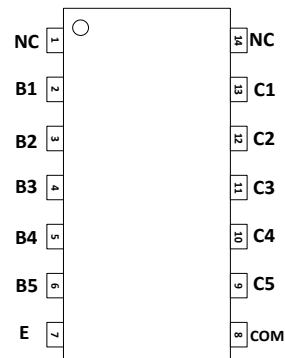

Characteristics

- 500mA collector output current (single circuit)
- High voltage resistance (50V)
- Input compatible TTL/CMOS logic signal
- Widely used in relay drive
- Input port has built-in 4K pull-down resistance to ground.

Typical applications

- Relay drive
- Indicator light driver
- Display driver

A new three-channel relay driver circuit that

Circuit Schematic (Single Darlington Driver Circuit)

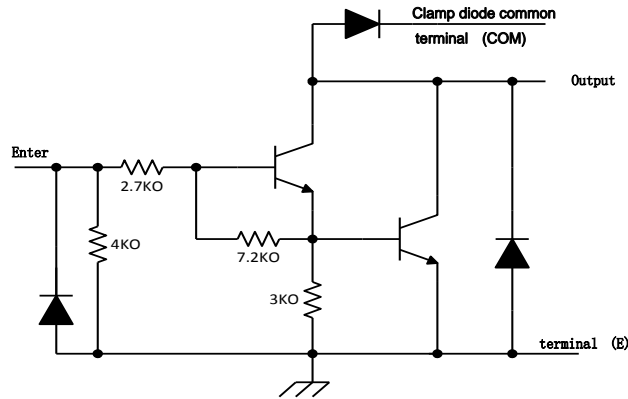

Schematic diagram of ULN2002D single circuit Darlington drive circuit

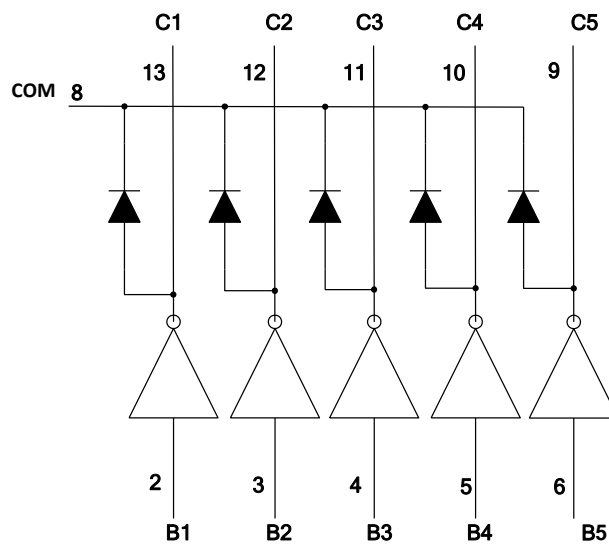

pin number	pin names	Input/Output	Pin Function Description
1	NC	-	Overhanging pins
2	B1	I	1-channel input pin
3	B2	I	2-channel input pin
4	B3	I	3-channel input pin
5	B4	I	4-channel input pin
6	B5	I	5-channel input pin
7	E	-	Grounding
8	COM	-	Clamp diode common
9	C5	O	5-channel output pin
10	C4	O	4-channel output pin
11	C3	O	3-channel output pin
12	C2	O	2-channel output pin
13	C1	O	1-channel output pin
14	NC	-	Overhanging pins

A new three-channel relay driver circuit that

Absolute maximum rating (TA=25 °C, unless otherwise specified)

parameters	Symbol	value	Unit
Collector emitter voltage (13-9 pins)	V _{CE}	50	V
COM terminal voltage (8 pins)	V _{COM}	50	V
Input voltage (2-6 pins)	V _I	30	V
Single collector peak current	I _{CP}	500	mA
Output clamp diode forward peak current	I _{OK}	500	mA
Maximum peak current of the total emitter	I _{ET}	-2	A
Packaging thermal impedance ⁽¹⁾⁽²⁾⁽³⁾	θ _{JA}	125	°C/W
Maximum operating junction temperature	T _J	150	°C
Welding temperature		260	°C, 10s
Storage temperature range	T _{stg}	-65 to +150	°C

Note: 1. The maximum power consumption can be calculated according to the following relationship

$$P_D = (T_J - T_A) / \theta_{JA} ;$$

2. T_J represents the junction temperature at which the circuit operates, and T_A represents the ambient temperature at which the circuit operates

Recommended operating conditions (TA=25 °C, unless otherwise specified)

parameters	Symbol	Condition	Mini	Max	Unit
Output terminal voltage	V _{CE(SUS)}		0	50	V
Output current	I _{OUT}	Continuous output, T _A = +85°C		90 60	mA/ch
INPUT VOLTAGE	V _{IN}		0	12	V
Input voltage (output turned on)	V _{IN(ON)}	I _{out} = 400mA	2.8	12	V
Input voltage (output shutdown)	V _{IN(OFF)}		0	0.7	V
Clamp diode reverse voltage	V _R			50	V
Clamp diode forward peak current	I _F			350	mA
Working temperature range	T _A		-40	+85	°C
Working temperature	T _J		-40	125	°C
Dissipative power consumption	P _D	T _A = +25°C T _A = +85°C		0.8 0.32	W

Note: 1. T_A represents the ambient temperature of the circuit;

2. The calculation method of circuit power consumption is: P_D = V_{CE(ON)1} × I_{C1} + V_{CE(ON)2} × I_{C2} + V_{CE(ON)3} × I_{C3} + V_{CE(ON)4} × I_{C4} + V_{CE(ON)5} × I_{C5} + V_{IN1} × I_{IIN1} + V_{IN2} × I_{IIN2} + V_{IN3} × I_{IIN3} + V_{IN4} × I_{IIN4} + V_{IN5} × I_{IIN5} ;

3. In Note 2, V_{CE(ON)n} represents the conduction voltage drop of the corresponding channel, where n=1,2,3,4,5, and I_{Cn} represents the average load current of the corresponding channel, where n=1,2,3,4,5; V_{INn} represents the average high level of the signal input for the corresponding channel, where n=1,2,3,4,5; I_{IINn} represents the average signal input current of the corresponding channel, where n=1,2,3,4,5.

A new three-channel relay driver circuit that

Electrical parameter characteristic table (TA=25 °C, unless otherwise specified)

parameters	Test chart	test conditions			Min	Typical	Max	Unit
V _{I(ON)} On -state input voltage	Figure 4	V _{CE} =1.5V (input not current limited)	T _A =0°C	I _C =30mA		1.74	2.1	V
				I _C =60mA		1.79	2.15	
				I _C =120mA		1.85	2.2	
				I _C =240mA		1.96	2.35	
				I _C =350mA		2.09	2.5	
			T _A =25°C	I _C =30mA		1.65	2	
				I _C =60mA		1.69	2	
				I _C =120mA		1.73	2.1	
				I _C =240mA		1.82	2.2	
				I _C =350mA		1.93	2.3	
		I _I =800uA (V _{CE} <1.5V)	T _A =0°C	I _C =30mA		2.14	2.57	
				I _C =60mA		2.17	2.6	
				I _C =120mA		2.22	2.66	
				I _C =240mA		2.33	2.8	
				I _C =350mA		2.44	2.93	
			T _A =25°C	I _C =30mA		2.17	2.6	
				I _C =60mA		2.2	2.64	
				I _C =120mA		2.25	2.7	
				I _C =240mA		2.35	2.82	
				I _C =350mA		2.45	2.94	
		I _I =1mA (V _{CE} <1.5V)	T _A =0°C	I _C =30mA		2.45	2.94	
				I _C =60mA		2.48	2.98	
				I _C =120mA		2.54	3.05	
				I _C =240mA		2.65	3.18	
I _C =350mA				2.77	3.32			
T _A =25°C	I _C =30mA			2.5	3			
	I _C =60mA			2.53	3.04			
	I _C =120mA			2.58	3.1			
	I _C =240mA			2.69	3.23			
	I _C =350mA			2.8	3.36			
V _{CE(SAT)} collect -or emitter saturation voltage drop	Figure 3	V _I =2.4V (I _I >800uA)	T _A =0°C	I _C =30mA		0.81		V
				I _C =60mA		0.86		
				I _C =120mA		0.94		
				I _C =240mA		1.12		
				I _C =350mA		1.3		
			T _A =25°C	I _C =30mA		0.76		
				I _C =60mA		0.81		
				I _C =120mA		0.88		
				I _C =240mA		1.03		
				I _C =350mA		1.2		

A new three-channel relay driver circuit that

Electrical Parameter Characteristics Table Continued

(TA=25 °C, unless otherwise specified)

parameters	Test chart	Test conditions	Mini	Typical	Max	Unit	
I _i Input Current	Figure 2	I _C =60mA	T _A =0°C	V _I =12V	7.03		mA
				V _I =6V	3.27		
				V _I =4.5V	2.16		
				V _I =2.4V	0.88		
			T _A =25°C	V _I =12V	6.5		
				V _I =6V	3.05		
				V _I =4.5V	2.04		
				V _I =2.4V	0.85		
V _F Clamp diode forward voltage drop	Figure 6	I _F =350mA		1.56	1.6	V	
				1.55	1.6		
I _{CEX} Collector turn off leakage current	Figure 1	V _{CE} =50V I _I =0		--	50	μA	
V _{CE} Collector withstand voltage	Figure 1	V _{CE} =50V I _I =0	50			V	
I _R Clamp diode reverse withstand voltage	Figure 5	V _R =50V	50			V	
I _R Clamp diode reverse leakage current	Figure 5	V _R =50V		--	50	μA	
t _{PLH} Low high transmission delay	Figure 7	V _L =12V R _L =45Ω		0.15	1	μs	
t _{PHL} Transmission delay high low	Figure 7	V _L =12V R _L =45Ω		0.15	1	μs	

Electrical parameter testing schematic diagram

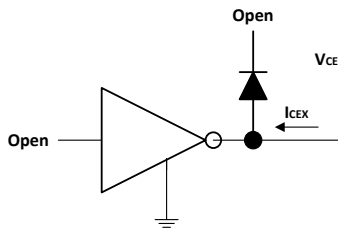

Figure 1 I_{CEX}

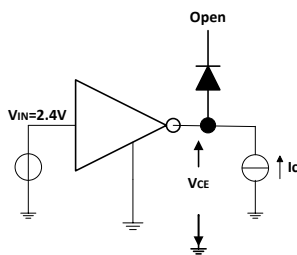

Figure 2 V_{CE(SAT)} Test Circuit

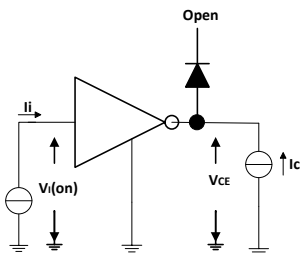

Figure 3 V_{I(on)} Test Circuit

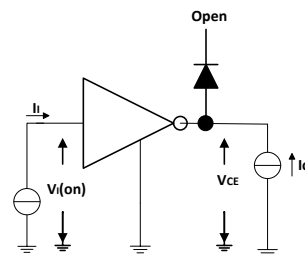

Figure 4 I_i Test Circuit

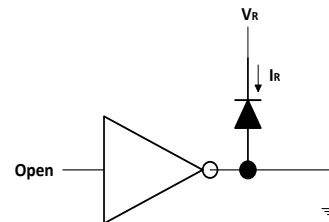

Figure 5 I_R Test Circuit

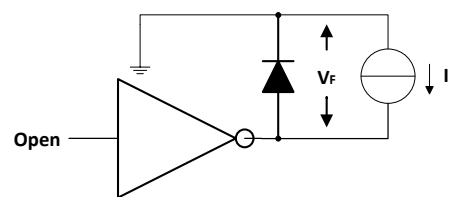

Figure 6 V_F Test Circuit

A new three-channel relay driver circuit that

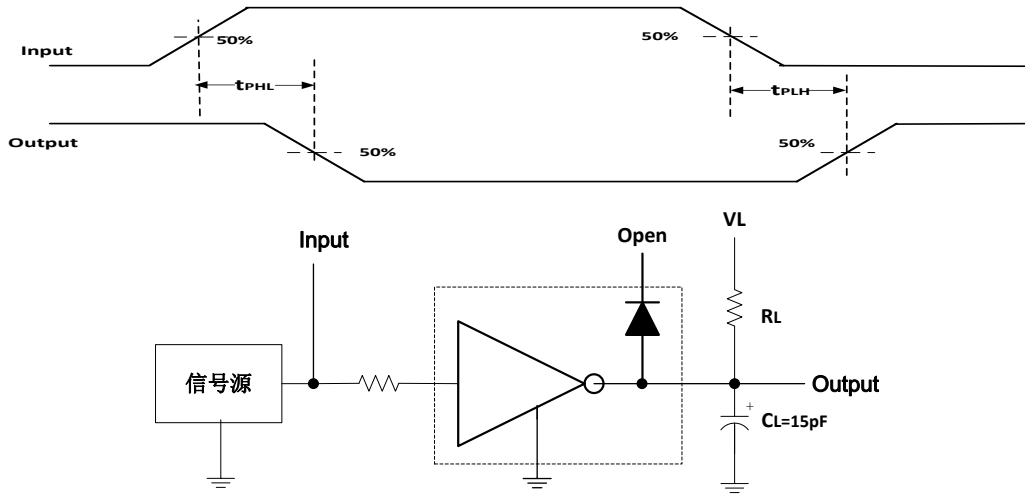
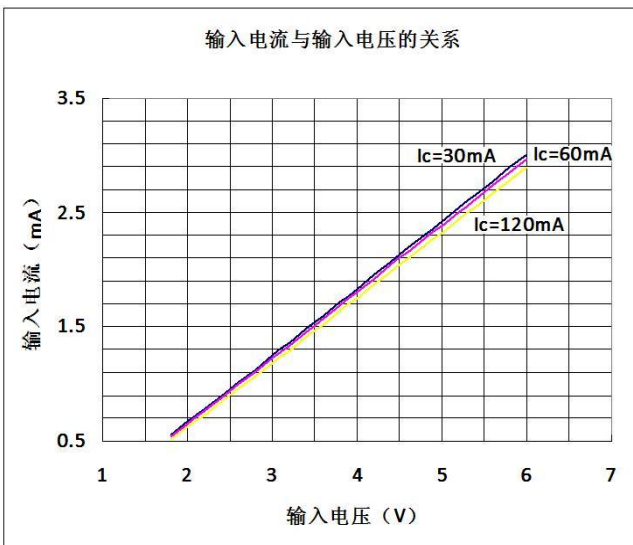
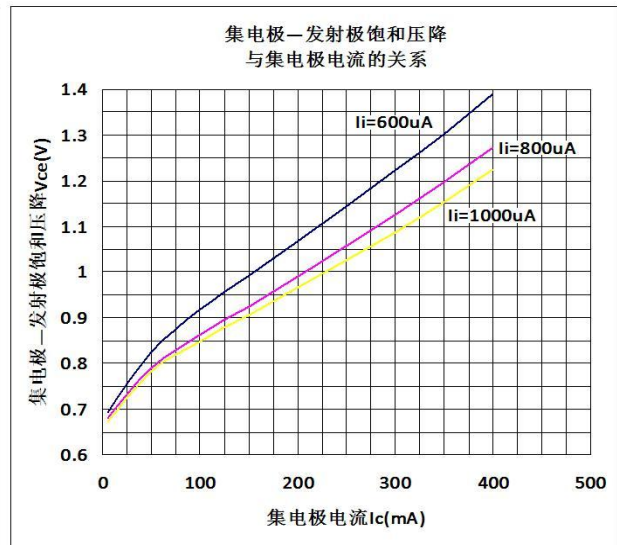

Fig. 7 Transmission delay test waveform

Note: The capacitive load in Figure 7 is the parasitic capacitance of the oscilloscope probe



Under a certain load, the input current I_i and the input voltage V_{in} relationship



At a certain input current, the collector-emitter saturation voltage Relationship between reduced V_{CE} and collector current I_C

Application Information

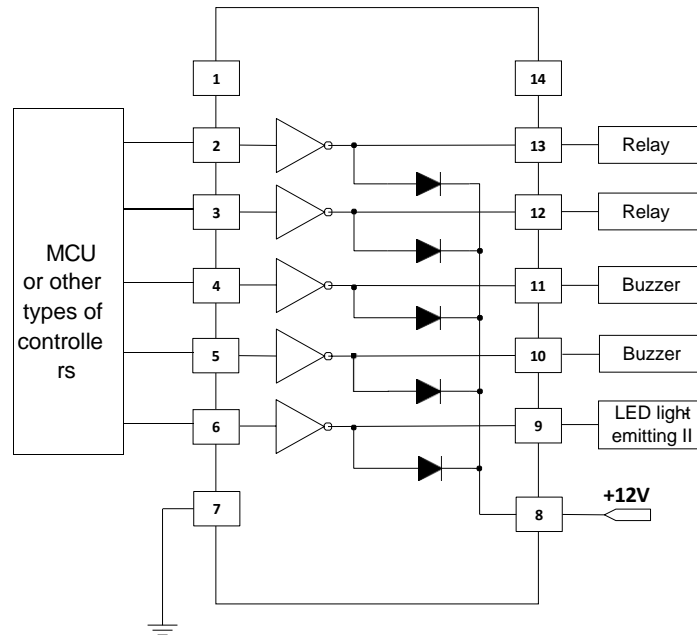

Figure 8 Typical application circuit diagram of ULN2002D

The application of ULN2002D is not limited to the application circuit diagram shown in Figure 8. In particular, the drive circuit load can be 5 relays or 5 LED's. The specific application depends on the actual situation. Figure 8 only shows the load types that can be driven by ULN2002D. In addition to the load type shown in Figure 8, ULN2002D can also drive stepping motor, toy motor and other loads.

Although ULN2002D is not a CMOS type electrostatic sensitive device, appropriate anti-static measures should be taken in actual use to avoid leakage, function failure and other situations when the device is subjected to too strong electrostatic pulse impact.

ULN2002D is widely used in relay drive circuits. When controlling 220V and other strong currents, special attention should be paid to the isolation between strong current and weak current to prevent strong current signals from coupling to the output end of the drive circuit, causing device breakdown and other failures.

A new three-channel relay driver circuit that

SOP-14

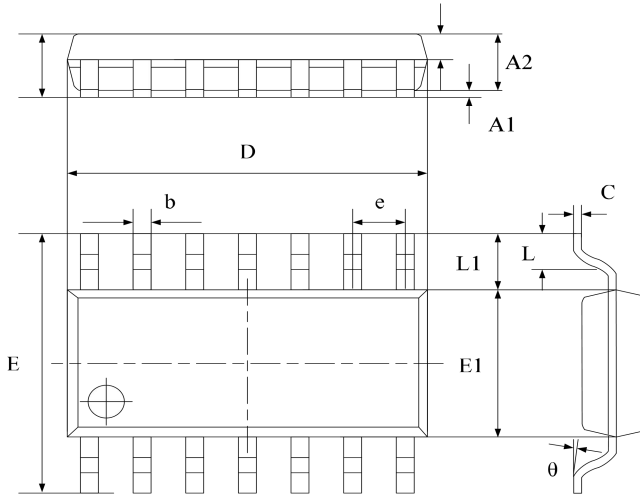

Symbol	Dimensions In Millimeters		Dimensions In Inches	
	Min	Max	Min	Max
A	1.450	1.850	0.059	0.076
A1	0.100	0.300	0.004	0.012
A2	1.350	1.550	0.055	0.063
A3	0.550	0.750	0.022	0.031
b	0.406typ.		0.017typ.	
C	0.203typ.		0.008typ.	
D	8.630	8.830	0.352	0.360
E	5.840	6.240	0.238	0.255
E1	3.850	4.050	0.157	0.165
e	1.270 typ.		0.050 typ.	
L1	1.040 ref.		0.041 ref.	
L	0.350	0.750	0.014	0.031
θ	2°	8°	2°	8°

Marking

Ordering information

Order code	Package	Baseqty	Deliverymode
UMW ULN2002D	SOP-14	2500	Tape and reel

X-ON Electronics

Largest Supplier of Electrical and Electronic Components

Click to view similar products for [Darlington Transistors](#) category:

Click to view products by [Youtai](#) manufacturer:

Other Similar products are found below :

[BDV64B](#) [2N6298](#) [NJVMJD117T4G](#) [2N6053](#) [MPSA63](#) [NTE256](#) [TIP120](#) [MJ11028](#) [TIP127](#) [Jantx2N6352](#) [2N6301](#) [NJVBUB323ZT4G](#)
[ULN2803QN](#) [KID65004AF-EL/P](#) [ULN2803CDWR](#) [MJ11033G-JSM](#) [MMBTA64](#) [TPM2003-SO3R](#) [KSP13](#) [TIP127](#) [TIP122](#) [TIP122F](#)
[TIP122-JSM](#) [ULN2003A-JSM](#) [MJ11032G-JSM](#) [KID65783BF-EL/P](#) [ULN2001D\(MS\)](#) [2SD1071](#) [MJ11028](#) [MJ11030](#) [MJ1000](#) [MJ11031](#)
[TIP160](#) [2N6287](#) [MJ11029](#) [MJ3001](#) [MJ2501](#) [ULN2001D\(UMW\)](#) [ULN2003APWR\(UMW\)](#) [ULN2003AIPWR\(UMW\)](#) [ULN2002D\(UMW\)](#)
[ULN2803G-P20-R](#) [WD2002](#) [AIP2003LSA16.TB](#) [AIP2803SA.TR](#) [AIP2803](#) [AIP2803LSA18.TB](#) [XL2803CD](#) [ULN2004MT/TR](#) [MMBTA13](#)