

Features

- Output Current up to 1A
- Output Voltages of 5, 6, 8, 9, 12, 15, 18, 24V
- Thermal Overload Protection Short Circuit Protection
- Output Transistor Safe Operating area (SOA)Protection

Description

The 78MXX three-terminal positive regulators are available in the TO-252 package with several fixed output voltages making it useful in a wide range of applications.

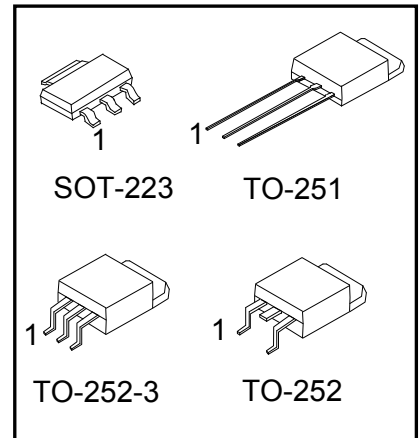

Internal Block Diagram

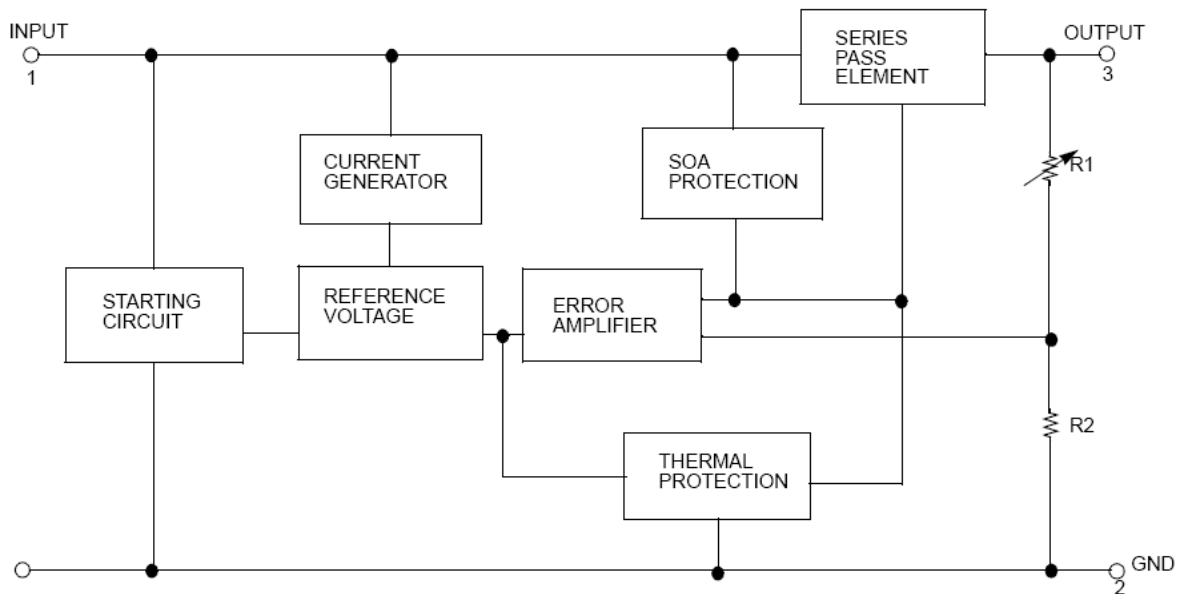

Absolute Maximum Ratings

PARAMETER	SYMBOL	RATINGS	UNIT
Input Voltage	V_{IN}	35	V
Output Current	I_{OUT}	1	A
Power Dissipation ($T_C=25^{\circ}C$)	SOT-223	1	W
	TO-251/TO-252	2	
	TO-252-3		
Operating Junction Temperature	T_J	-20 ~ 125	
Storage Temperature	T_{STG}	-55 ~ +150	

Thermal Data

PARAMETER		SYMBOL	RATINGS	UNIT
Junction to Case	SOT-223	θ_{JC}	15	°C/W
	TO-251/TO-252		12.5	
	TO-252-3			

Electrical Characteristics (78M05)

(Refer to the test circuits, $0 < T_J < +125^{\circ}\text{C}$, $I_O=350\text{mA}$, $V_I=10\text{V}$, unless otherwise specified, $C_I = 0.33\mu\text{F}$, $C_O=0.1\mu\text{F}$)

Parameter	Symbol	Conditions	Value			Unit
			Min	Typ	Max	
Output Voltage	V_O	$I_O = 5\text{mA} \sim 350\text{mA}$ $V_I = 7 \sim 20\text{V}$	4.75	5	5.25	V
Line Regulation(Note)	ΔV_O	$I_O = 200\text{mA}$ $T_j = 25^{\circ}\text{C}$	$V_I = 7\text{V} \sim 25\text{V}$		100	mV
			$V_I = 8\text{V} \sim 25\text{V}$		50	
Load Regulation(Note)	ΔV_O	$T_j = 25^{\circ}\text{C}$	$I_O = 5\text{mA} \sim 500\text{mA}$		100	mV
			$I_O = 5\text{mA} \sim 200\text{mA}$		50	
Quiescent Current	I_Q	$T_j = 25^{\circ}\text{C}$			6.0	mA
Quiescent Current Change	ΔI_Q	$I_O = 5\text{mA} \sim 350\text{mA}$			0.5	mA
		$I_O = 200\text{mA}$, $V_I = 8 \sim 25\text{V}$			0.8	
Output Voltage Drift	$\Delta V / \Delta T$	$I_O = 5\text{mA}$, $T_j = 0 \sim 125^{\circ}\text{C}$		-0.5		mV/°C
Output Noise Voltage	V_N	$f = 10\text{Hz} \sim 100\text{KHz}$		40		μV
Ripple Rejection	RR	$f = 120\text{Hz}$, $V_I = 8 \sim 18\text{V}$		80		dB
Dropout Voltage	V_D	$T_j = 25^{\circ}\text{C}$, $I_O = 500\text{mA}$		2		V
Short Circuit Current	I_{SC}	$T_j = 25^{\circ}\text{C}$, $V_I = 35\text{V}$		800		mA
Peak Current	I_{PK}	$T_j = 25^{\circ}\text{C}$		900		mA

Notes:

Load and line regulation are specified at constant junction temperature. Change in V_O due to heating effects must be taken into account separately. Pulse testing with low duty is used.

Electrical Characteristics (78M06)

(Refer to the test circuits, $0 < T_j < +125^{\circ}\text{C}$, $I_o=350\text{mA}$, $V_i=11\text{V}$, unless otherwise specified, $C_i = 0.33\mu\text{F}$, $C_o=0.1\mu\text{F}$)

Parameter	Symbol	Conditions	Value			Unit
			Min	Typ	Max	
Output Voltage	V_o	$I_o = 5\text{mA} \sim 350\text{mA}$ $V_i = 8 \sim 21\text{V}$	5.7	6	6.3	V
Line Regulation(Note)	ΔV_o	$I_o = 200\text{mA}$ $T_j = 25^{\circ}\text{C}$	$V_i = 8\text{V} \sim 25\text{V}$		100	mV
			$V_i = 9\text{V} \sim 25\text{V}$		50	
Load Regulation(Note)	ΔV_o	$T_j = 25^{\circ}\text{C}$	$I_o = 5\text{mA} \sim 500\text{mA}$		120	mV
			$I_o = 5\text{mA} \sim 200\text{mA}$		60	
Quiescent Current	I_Q	$T_j = 25^{\circ}\text{C}$			6.0	mA
Quiescent Current Change	ΔI_Q	$I_o = 5\text{mA} \sim 350\text{mA}$			0.5	mA
		$I_o = 200\text{mA}$, $V_i = 9 \sim 25\text{V}$			0.8	
Output Voltage Drift	$\Delta V / \Delta T$	$I_o = 5\text{mA}$, $T_j = 0 \sim 125^{\circ}\text{C}$		-0.5		mV/ $^{\circ}\text{C}$
Output Noise Voltage	V_N	$f = 10\text{Hz} \sim 100\text{KHz}$		45		μV
Ripple Rejection	RR	$f = 120\text{Hz}$, $V_i = 9 \sim 19\text{V}$		80		dB
Dropout Voltage	V_D	$T_j = 25^{\circ}\text{C}$, $I_o = 500\text{mA}$		2		V
Short Circuit Current	I_{SC}	$T_j = 25^{\circ}\text{C}$, $V_i = 35\text{V}$		800		mA
Peak Current	I_{PK}	$T_j = 25^{\circ}\text{C}$		900		mA

Notes:

Load and line regulation are specified at constant junction temperature. Change in V_o due to heating effects must be taken into account separately. Pulse testing with low duty is used.

Electrical Characteristics (78M08)

(Refer to the test circuits, $0 < T_j < +125^{\circ}\text{C}$, $I_o=350\text{mA}$, $V_i=14\text{V}$, unless otherwise specified, $C_i = 0.33\mu\text{F}$, $C_o=0.1\mu\text{F}$)

Parameter	Symbol	Conditions	Value			Unit
			Min	Typ	Max	
Output Voltage	V_o	$I_o = 5\text{mA} \sim 350\text{mA}$ $V_i = 10.5 \sim 23\text{V}$	7.6	8	8.4	V
Line Regulation(Note)	ΔV_o	$I_o = 200\text{mA}$ $T_j = 25^{\circ}\text{C}$	$V_i = 10.5\text{V} \sim 25\text{V}$		100	mV
			$V_i = 11\text{V} \sim 25\text{V}$		50	
Load Regulation(Note)	ΔV_o	$T_j = 25^{\circ}\text{C}$	$I_o = 5\text{mA} \sim 500\text{mA}$		160	mV
			$I_o = 5\text{mA} \sim 200\text{mA}$		80	
Quiescent Current	I_q	$T_j = 25^{\circ}\text{C}$			6.0	mA
Quiescent Current Change	ΔI_q	$I_o = 5\text{mA} \sim 350\text{mA}$			0.5	mA
		$I_o = 200\text{mA}$, $V_i = 10.5 \sim 25\text{V}$			0.8	
Output Voltage Drift	$\Delta V / \Delta T$	$I_o = 5\text{mA}$, $T_j = 0 \sim 125^{\circ}\text{C}$		-0.8		mV/ $^{\circ}\text{C}$
Output Noise Voltage	V_N	$f = 10\text{Hz} \sim 100\text{KHz}$		52		μV
Ripple Rejection	RR	$f = 120\text{Hz}$, $V_i = 11.5 \sim 21.5\text{V}$		80		dB
Dropout Voltage	V_D	$T_j = 25^{\circ}\text{C}$, $I_o = 500\text{mA}$		2		V
Short Circuit Current	I_{SC}	$T_j = 25$, $V_i = 35\text{V}$		800		mA
Peak Current	I_{PK}	$T_j = 25^{\circ}\text{C}$		900		mA

Notes:

Load and line regulation are specified at constant junction temperature. Change in V_o due to heating effects must be taken into account separately. Pulse testing with low duty is used.

Electrical Characteristics (78M09)

(Refer to the test circuits, $0 < T_j < +125^{\circ}\text{C}$, $I_o=350\text{mA}$, $V_i=15\text{V}$, unless otherwise specified, $C_i = 0.33\mu\text{F}$, $C_o=0.1\mu\text{F}$)

Parameter	Symbol	Conditions	Value			Unit
			Min	Typ	Max	
Output Voltage	V_o	$I_o = 5\text{mA} \sim 350\text{mA}$ $V_i = 11.5 \sim 24\text{V}$	8.45	9	9.55	V
Line Regulation(Note)	ΔV_o	$I_o = 200\text{mA}$ $T_j = 25^{\circ}\text{C}$	$V_i = 11.5\text{V} \sim 25\text{V}$		100	mV
			$V_i = 12\text{V} \sim 25\text{V}$		50	
Load Regulation(Note)	ΔV_o	$T_j = 25^{\circ}\text{C}$	$I_o = 5\text{mA} \sim 500\text{mA}$		180	mV
			$I_o = 5\text{mA} \sim 200\text{mA}$		90	
Quiescent Current	I_q	$T_j = 25^{\circ}\text{C}$			6.0	mA
Quiescent Current Change	ΔI_q	$I_o = 5\text{mA} \sim 350\text{mA}$			0.5	mA
		$I_o = 200\text{mA}$, $V_i = 11.5 \sim 25\text{V}$			0.8	
Output Voltage Drift	$\Delta V / \Delta T$	$I_o = 5\text{mA}$, $T_j = 0 \sim 125^{\circ}\text{C}$		-0.8		mV/ $^{\circ}\text{C}$
Output Noise Voltage	V_N	$f = 10\text{Hz} \sim 100\text{KHz}$		52		μV
Ripple Rejection	RR	$f = 120\text{Hz}$, $V_i = 12.5 \sim 22.5\text{V}$		80		dB
Dropout Voltage	V_D	$T_j = 25^{\circ}\text{C}$, $I_o = 500\text{mA}$		2		V
Short Circuit Current	I_{SC}	$T_j = 25^{\circ}\text{C}$, $V_i = 35\text{V}$		800		mA
Peak Current	I_{PK}	$T_j = 25^{\circ}\text{C}$		900		mA

Notes:

Load and line regulation are specified at constant junction temperature. Change in V_o due to heating effects must be taken into account separately. Pulse testing with low duty is used.

Electrical Characteristics (78M12)

(Refer to the test circuits, $0 < T_j < +125^{\circ}\text{C}$, $I_o=350\text{mA}$, $V_i=19\text{V}$, unless otherwise specified, $C_i = 0.33\mu\text{F}$, $C_o=0.1\mu\text{F}$)

Parameter	Symbol	Conditions	Value			Unit
			Min	Typ	Max	
Output Voltage	V_o	$I_o = 5\text{mA} \sim 350\text{mA}$ $V_i = 14.5 \sim 27\text{V}$	11.4	12	12.6	V
Line Regulation(Note)	ΔV_o	$I_o = 200\text{mA}$ $T_j = 25^{\circ}\text{C}$	$V_i = 14.5\text{V} \sim 30\text{V}$		100	mV
			$V_i = 16\text{V} \sim 30\text{V}$		50	
Load Regulation(Note)	ΔV_o	$T_j = 25^{\circ}\text{C}$	$I_o = 5\text{mA} \sim 500\text{mA}$		240	mV
			$I_o = 5\text{mA} \sim 200\text{mA}$		120	
Quiescent Current	I_Q	$T_j = 25^{\circ}\text{C}$			6.0	mA
Quiescent Current Change	ΔI_Q	$I_o = 5\text{mA} \sim 350\text{mA}$			0.5	mA
		$I_o = 200\text{mA}$, $V_i = 14.5 \sim 30\text{V}$			0.8	
Output Voltage Drift	$\Delta V / \Delta T$	$I_o = 5\text{mA}$, $T_j = 0 \sim 125^{\circ}\text{C}$		-0.8		mV/ $^{\circ}\text{C}$
Output Noise Voltage	V_N	$f = 10\text{Hz} \sim 100\text{KHz}$		75		μV
Ripple Rejection	RR	$f = 120\text{Hz}$, $V_i = 15 \sim 25\text{V}$		80		dB
Dropout Voltage	V_D	$T_j = 25^{\circ}\text{C}$, $I_o = 500\text{mA}$		2		V
Short Circuit Current	I_{SC}	$T_j = 25^{\circ}\text{C}$, $V_i = 35\text{V}$		800		mA
Peak Current	I_{PK}	$T_j = 25^{\circ}\text{C}$		900		mA

Notes:

Load and line regulation are specified at constant junction temperature. Change in V_o due to heating effects must be taken into account separately. Pulse testing with low duty is used.

Electrical Characteristics (78M15)

(Refer to the test circuits, $0 < T_j < +125^{\circ}\text{C}$, $I_o=350\text{mA}$, $V_i=23\text{V}$, unless otherwise specified, $C_i = 0.33\mu\text{F}$, $C_o=0.1\mu\text{F}$)

Parameter	Symbol	Conditions	Value			Unit
			Min	Typ	Max	
Output Voltage	V_o	$I_o = 5\text{mA} \sim 350\text{mA}$ $V_i = 17.5 \sim 30\text{V}$	14.25	15	15.75	V
Line Regulation(Note)	ΔV_o	$I_o = 200\text{mA}$ $T_j = 25^{\circ}\text{C}$	$V_i = 17.5\text{V} \sim 30\text{V}$		100	mV
			$V_i = 20\text{V} \sim 30\text{V}$		50	
Load Regulation(Note)	ΔV_o	$T_j = 25^{\circ}\text{C}$	$I_o = 5\text{mA} \sim 500\text{mA}$		300	mV
			$I_o = 5\text{mA} \sim 200\text{mA}$		150	
Quiescent Current	I_q	$T_j = 25^{\circ}\text{C}$			6.0	mA
Quiescent Current Change	ΔI_q	$I_o = 5\text{mA} \sim 350\text{mA}$			0.5	mA
		$I_o = 200\text{mA}$, $V_i = 17.5 \sim 30\text{V}$			0.8	
Output Voltage Drift	$\Delta V / \Delta T$	$I_o = 5\text{mA}$, $T_j = 0 \sim 125^{\circ}\text{C}$		-1.0		mV/ $^{\circ}\text{C}$
Output Noise Voltage	V_N	$f = 10\text{Hz} \sim 100\text{KHz}$		100		μV
Ripple Rejection	RR	$f = 120\text{Hz}$, $V_i = 18.5 \sim 28.5\text{V}$		70		dB
Dropout Voltage	V_D	$T_j = 25^{\circ}\text{C}$, $I_o = 500\text{mA}$		2		V
Short Circuit Current	I_{SC}	$T_j = 25^{\circ}\text{C}$, $V_i = 35\text{V}$		800		mA
Peak Current	I_{PK}	$T_j = 25^{\circ}\text{C}$		900		mA

Notes:

Load and line regulation are specified at constant junction temperature. Change in V_o due to heating effects must be taken into account separately. Pulse testing with low duty is used.

Electrical Characteristics (78M18)

(Refer to the test circuits, $0 < T_j < +125^{\circ}\text{C}$, $I_o=350\text{mA}$, $V_i=26\text{V}$, unless otherwise specified, $C_i = 0.33\mu\text{F}$, $C_o=0.1\mu\text{F}$)

Parameter	Symbol	Conditions	Value			Unit
			Min	Typ	Max	
Output Voltage	V_o	$I_o = 5\text{mA} \sim 350\text{mA}$ $V_i = 20.5 \sim 33\text{V}$	17.1	18	18.9	V
Line Regulation(Note)	ΔV_o	$I_o = 200\text{mA}$ $T_j = 25^{\circ}\text{C}$	$V_i = 21\text{V} \sim 33\text{V}$		100	mV
			$V_i = 24\text{V} \sim 33\text{V}$		50	
Load Regulation(Note)	ΔV_o	$T_j = 25^{\circ}\text{C}$	$I_o = 5\text{mA} \sim 500\text{mA}$		360	mV
			$I_o = 5\text{mA} \sim 200\text{mA}$		180	
Quiescent Current	I_q	$T_j = 25^{\circ}\text{C}$			6.0	mA
Quiescent Current Change	ΔI_q	$I_o = 5\text{mA} \sim 350\text{mA}$			0.5	mA
		$I_o = 200\text{mA}$, $V_i = 21 \sim 33\text{V}$			0.8	
Output Voltage Drift	$\Delta V / \Delta T$	$I_o = 5\text{mA}$, $T_j = 0 \sim 125^{\circ}\text{C}$		-1.2		mV/ $^{\circ}\text{C}$
Output Noise Voltage	V_N	$f = 10\text{Hz} \sim 100\text{KHz}$		100		μV
Ripple Rejection	RR	$f = 120\text{Hz}$, $V_i = 22 \sim 32\text{V}$		70		dB
Dropout Voltage	V_D	$T_j = 25^{\circ}\text{C}$, $I_o = 500\text{mA}$		2		V
Short Circuit Current	I_{SC}	$T_j = 25$, $V_i = 35\text{V}$		800		mA
Peak Current	I_{PK}	$T_j = 25^{\circ}\text{C}$		900		mA

Notes:

Load and line regulation are specified at constant junction temperature. Change in V_o due to heating effects must be taken into account separately. Pulse testing with low duty is used.

Electrical Characteristics (78M24)

(Refer to the test circuits, $0 < T_j < +125^{\circ}\text{C}$, $I_o=350\text{mA}$, $V_i=33\text{V}$, unless otherwise specified, $C_i = 0.33\mu\text{F}$, $C_o=0.1\mu\text{F}$)

Parameter	Symbol	Conditions	Value			Unit
			Min	Typ	Max	
Output Voltage	V_o	$I_o = 5\text{mA} \sim 350\text{mA}$ $V_i = 27 \sim 38\text{V}$	22.8	24	25.2	V
Line Regulation(Note)	ΔV_o	$I_o = 200\text{mA}$ $T_j = 25^{\circ}\text{C}$	$V_i = 27\text{V} \sim 38\text{V}$		100	mV
			$V_i = 28\text{V} \sim 38\text{V}$		50	
Load Regulation(Note)	ΔV_o	$T_j = 25^{\circ}\text{C}$	$I_o = 5\text{mA} \sim 500\text{mA}$		480	mV
			$I_o = 5\text{mA} \sim 200\text{mA}$		240	
Quiescent Current	I_q	$T_j = 25^{\circ}\text{C}$			6.0	mA
Quiescent Current Change	ΔI_q	$I_o = 5\text{mA} \sim 350\text{mA}$			0.5	mA
		$I_o = 200\text{mA}$, $V_i = 27 \sim 38\text{V}$			0.8	
Output Voltage Drift	$\Delta V / \Delta T$	$I_o = 5\text{mA}$, $T_j = 0 \sim 125^{\circ}\text{C}$		-1.2		mV/ $^{\circ}\text{C}$
Output Noise Voltage	V_N	$f = 10\text{Hz} \sim 100\text{KHz}$		170		μV
Ripple Rejection	RR	$f = 120\text{Hz}$, $V_i = 28 \sim 38\text{V}$		70		dB
Dropout Voltage	V_D	$T_j = 25^{\circ}\text{C}$, $I_o = 500\text{mA}$		2		V
Short Circuit Current	I_{SC}	$T_j = 25$, $V_i = 35\text{V}$		800		mA
Peak Current	I_{PK}	$T_j = 25^{\circ}\text{C}$		900		mA

Notes:

Load and line regulation are specified at constant junction temperature. Change in V_o due to heating effects must be taken into account separately. Pulse testing with low duty is used.

SOT-223 Package Information

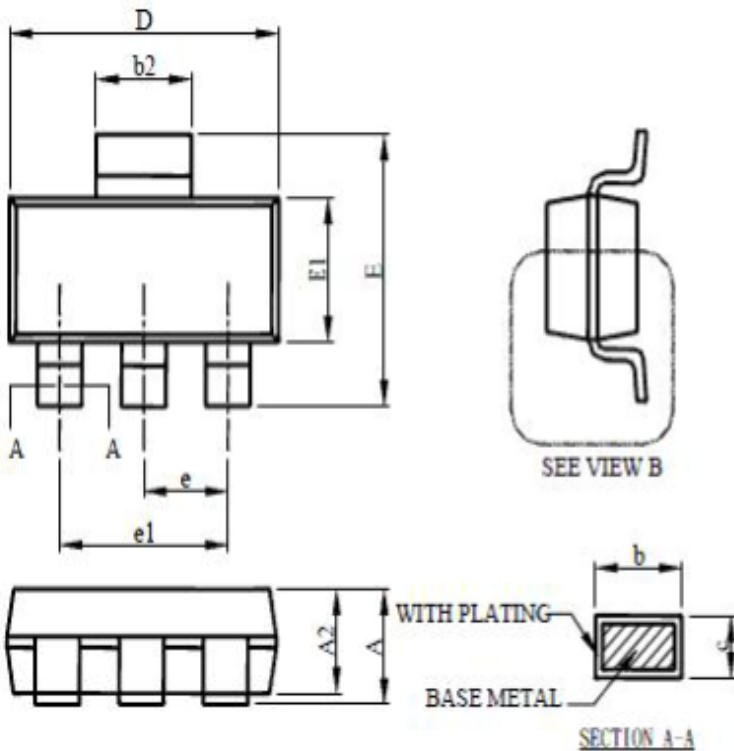

SYMBOL	SOT-223	
	MILLIMETERS	
	MIN.	MAX.
A		1.80
A1	0.02	0.10
A2	1.55	1.65
b	0.68	0.84
b2	2.90	3.10
c	0.23	0.33
D	6.30	6.70
E	6.70	7.30
E1	3.30	3.70
e	2.30 BSC	
e1	4.60 BSC	
L	0.90	
θ	0°	8°

TO-252 Package Information

X-ON Electronics

Largest Supplier of Electrical and Electronic Components

Click to view similar products for [Linear Voltage Regulators](#) category:

Click to view products by [Youtai](#) manufacturer:

Other Similar products are found below :

[LV56831P-E](#) [LV5684PVD-XH](#) [MCDTSA6-2R](#) [L7815ACV-DG](#) [PQ3DZ53U](#) [LV56801P-E](#) [L78L05CZ/1SX](#) [L78LR05DL-MA-E](#) [636416C](#)
[714954EB](#) [ZMR500QFTA](#) [LV5680P-E](#) [L78M15CV-DG](#) [L79M05T-E](#) [MIC5283-5.0YML-T5](#) [TLS202A1MBVHTSA1](#) [L78LR05D-MA-E](#)
[NCV317MBTG](#) [NTE7227](#) [MP2018GZD-33-P](#) [MP2018GZD-5-P](#) [LV5680NPVC-XH](#) [LT1054CN8](#) [MP2018GZD-5-Z](#) [MP2018GZD-33-Z](#)
[MD57E21WB6](#) [MD57E28WB6](#) [WL2810D33-4/TR](#) [WL2815D33-4/TR](#) [ZTS6538SE](#) [MC78L06BP-AP](#) [TA48LS05F\(TE85L,F\)](#)
[TA78L12F\(TE12L,F\)](#) [TC47BR5003ECT](#) [TCR2LN12,LF\(S](#) [TCR2LN28,LF\(S](#) [TCR2LN30,LF\(S](#) [TCR3DF295,LM\(CT](#) [TCR3DF40,LM\(CT](#)
[TPS549B22RVFT](#) [L78M12ABDT](#) [LM7812SX/NOPB](#) [LR645N3-G-P003](#) [LR645N3-G-P013](#) [ZXTR2005P5-13](#) [SCD7812BTG](#)
[TCR3DF335,LM\(CT](#) [ZXTR2012K-13](#) [TLE42994E V33](#) [ZXTR2008K-13](#)