

**CURRENT MODE PWM CONTROL CIRCUITS**

**DESCRIPTION**

The UTC3843D/E provides the necessary features to implement off-line or DC to DC fixed frequency current mode control schemes with a minimal external parts count. Internally implemented circuits include under-voltage lockout featuring start up current less than 1mA, a precision reference trimmed for accuracy at the error amp input, logic to insure latched operation, a PWM comparator which also provides current limit control, and a totem pole output stage designed to source or sink high peak current. The output stage, suitable for driving N channel MOSFETs, is low in the off state.

**FEATURES**

- \*Optimized for off-line and DC to DC converts
- \*Low start up current(<1mA)
- \*Automatic feed forward compensation
- \*Pulse-by-Pulse current limiting
- \*Enhanced load response characteristics
- \*Under-voltage lockout with hysteresis
- \*Double pulse Suppression
- \*High current totem pole output
- \*Internally trimmed bandgap reference
- \*500kHz operation
- \*Low Ro error amp

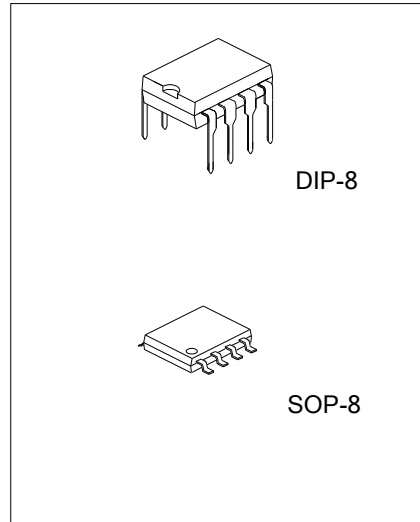

**ORDERING INFORMATION**

Device	Package
UTC3843D	DIP-8-300-2.54
UTC3843E	SOP-8-225-1.27

**BLOCK DIAGRAM**

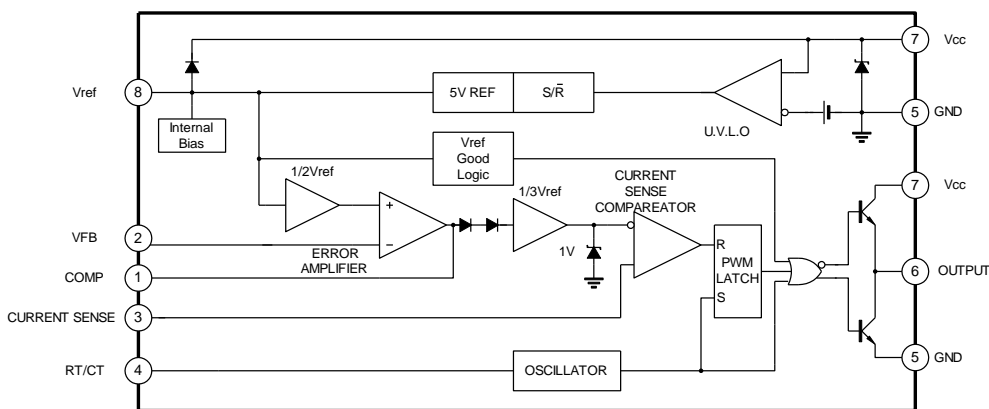

**ABSOLUTE MAXIMUM RATINGS**( $T_a=25^{\circ}\text{C}$ )

Characteristic	Symbol	Value	Unit
Supply Voltage(Low Impedence Source)	V <sub>CC</sub>	30	V
Supply Voltage(I <sub>CC</sub> <30mA)	V <sub>CC</sub>	Self Limiting	V
Output Current	I <sub>O</sub>	±1	A
Output Energy(capacitive Load)		5	μJ
Analog Inputs(pin 2,3)	V <sub>I(ANA)</sub>	-0.3 to +6.3	V
Error Amplifier Output Sink Current	I <sub>SINK(EA)</sub>	10	mA
Power Dissipation	P <sub>D</sub>	at T <sub>amb</sub> ≤25°C 1.0	W
Lead Temperature	T <sub>lead</sub>	300	°C
Storage Temperature	T <sub>stg</sub>	-65~+150	°C

Note 1:  $T_a>25^{\circ}\text{C}$ , P<sub>D</sub> derated with 8mW/°C.

**ELECTRICAL CHARACTERISTICS**

( $0\leq T_a\leq 70^{\circ}\text{C}$ , V<sub>CC</sub>=15V, R<sub>T</sub>=10kΩ, C<sub>T</sub>=3.3nF, unless otherwise specified)

Characteristic	Symbol	Test Conditions	Min	Typ	Max	Units
<b>Reference Section</b>						
Output Voltage	V <sub>REF</sub>	T <sub>J</sub> =25°C, I <sub>O</sub> =1mA	4.90	5.00	5.10	V
Line Regulation	ΔV <sub>REF</sub>	12≤V <sub>IN</sub> ≤25V		6	20	mV
Load Regulation	ΔV <sub>REF</sub>	1≤I <sub>O</sub> ≤20mA		6	25	mV
Temp Dtability		(Note 2)		0.2	0.4	mV/°C
Total Output Variation		Line, Load, Temp(note 2)	4.82		5.18	μV
Output Noise Voltage	V <sub>osc</sub>	10Hz≤f≤10kHz, T <sub>J</sub> =25°C (note 2)		50		mV
Long term stability		T <sub>a</sub> =25°C, 1000Hrs(note 2)		5	25	mV
Output Short Circuit	I <sub>sc</sub>		-30	-100	-180	mA
<b>Oscillator Section</b>						
Initial Accuracy	f	T <sub>J</sub> =25°C	47	52	57	kHz
Voltage Stability	Δf/ΔV <sub>CC</sub>	12≤V <sub>CC</sub> ≤25V		0.2	1	%
Temp stability		T <sub>min</sub> ≤T <sub>A</sub> ≤T <sub>max</sub> (note 2)		5		%
Amplitude	V <sub>osc</sub>	V <sub>pin 4</sub> peak to peak		1.7		V
<b>Error Amplifier Section</b>						
Input Voltage	V <sub>I(EA)</sub>	V <sub>pin 1</sub> =2.5V	2.42	2.50	2.58	V
Input Bias current	I <sub>BIAS</sub>			-0.3	-2	μA
AVOL		2 ≤V <sub>O</sub> ≤4V	60	90		dB
Unity Gain Bandwidth		T <sub>J</sub> =25°C (note 2)	0.7	1		mHz
PSRR		12≤V <sub>CC</sub> ≤25V	60	70		dB
Output Sink Current	I <sub>sink</sub>	V <sub>pin 2</sub> =2.7V, V <sub>pin 1</sub> =1.1V	2	6		mA
Output Source Current	I <sub>source</sub>	V <sub>pin 2</sub> =2.3V, V <sub>pin 1</sub> =5V	-0.5	-0.8		mA
V <sub>out High</sub>	V <sub>OH</sub>	V <sub>pin 2</sub> =2.3V, R <sub>L</sub> =15kΩ to GND	5	6		V
V <sub>out Low</sub>	V <sub>OL</sub>	V <sub>pin 2</sub> =2.7V, V <sub>pin 1</sub> =1.1V		0.7	1.1	V
<b>Current Sense section</b>						
Gain	G <sub>V</sub>	(note 3,4)	2.85	3	3.15	V/V
Maximum Input signal	V <sub>I(MAX)</sub>	V <sub>pin 1</sub> =5V (note 3)	0.9	1	1.1	V
PSRR		12≤V <sub>CC</sub> ≤25V		70		dB
Input Bias Current	I <sub>BIAS</sub>			-2	-10	μA
Delay to Output		V <sub>pin 3</sub> =0 to 2V		150	300	ns
<b>Output Section</b>						
Output low Level	V <sub>OL</sub>	I <sub>sink</sub> =20mA		0.1	0.4	V
		I <sub>sink</sub> =200mA		1.5	2.2	V

(continued)

Characteristic	Symbol	Test Conditions	Min	Typ	Max	Units
Output High Level	VOH	Isource=20mA	13	13.5		V
		Isource=200mA	12	13.5		V
Rise Time	tR	Tj=25°C, CL=1nF(note 2)		50	150	ns
Fall Time	tF	Tj=25°C, CL=1nF(note 2)		50	150	ns
UVLO Saturation		Vcc=5V, Isink=10mA		0.7	1.2	V
<b>Under-Voltage Lockout Output Section</b>						
Start Threshold	VTH(ST)		7.8	8.4	9.0	V
Min. Operating Voltage After Turn On	VOPR(min)		7.0	7.6	8.2	V
<b>PWM Section</b>						
Maximum duty Cycle	D(MAX)		95	97	100	%
Minimum Duty Cycle	D(MIN)				0	%
<b>Total Standby Current</b>						
Start-up Current	Ist			0.5	1	mA
Operating Supply Current	ICC(opr)	Vpin 2=Vpin 3=0V		11	17	mA
Vcc Zener Voltage	Vz	Icc=25mA		34		V

note 2: These parameters, although guaranteed, are not 100% tested in production.

note 3: Parameters measured at trip point of latch with Vpin 2=0.

note 4: Gain defined as:

$$A = \frac{\Delta V_{pin 1}}{\Delta V_{pin 3}} ; 0 \leq V_{pin 3} \leq 0.8V$$

note 5: Adjust Vcc above the start threshold before setting at 15V.

**OPEN-LOOP LABORATORY TEST CIRCUIT**

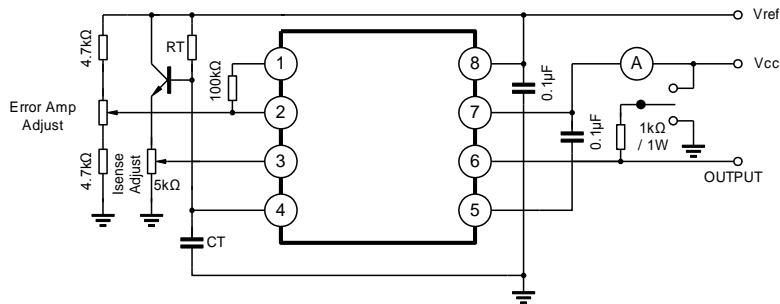

High peak current associated with capacitive loads necessitate careful grounding techniques. Timing and bypass capacitors should be connected close to pin 5

in single point GND. The transistor and 5kΩ potentiometer are used to sample the oscillator waveform and apply an adjustable Ramp to Pin 3.

**UNDER-VOLTAGE LOCKOUT**

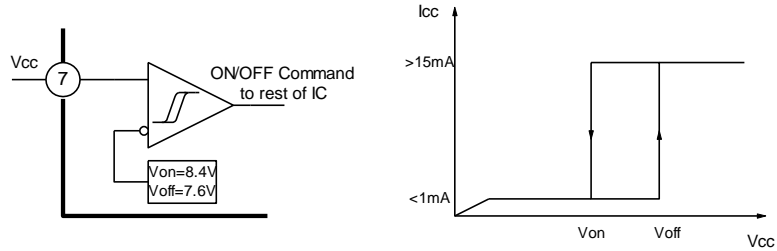

During Under-Voltage Lockout, the output driver is biased to a high impedance state. Pin 6 should be shunt to GND with a bleeder resistor to prevent

activating the power switch with output leakage currents.

**ERROR AMPLIFIER CONFIGURATION**

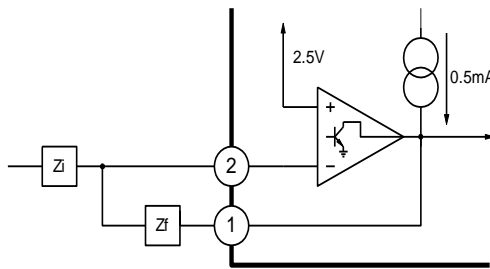

Error amplifier can source or sink up to 0.5mA

**CURRENT SENSE CIRCUIT**

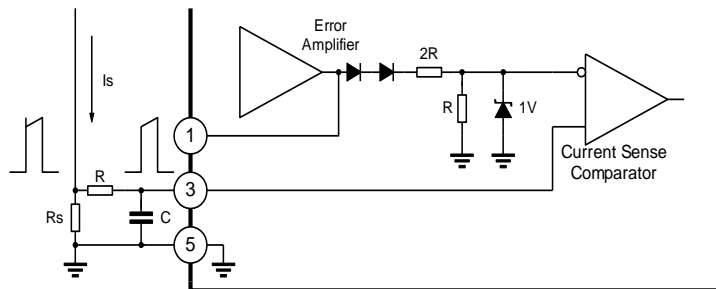

Peak current ( $I_s$ ) determined by the formula:  
 $I_{smax} = 10V/R_s$ .  
 A small RC filter be required to suppress switch transients.

**SLOPE COMPENSATION**

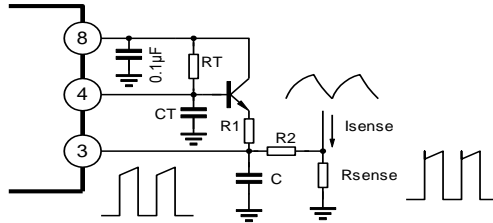

A fraction of the oscillator ramp can be resistively summed with the current sense signal to provide slope compensation for converts requiring duty cycles over

50%. Note that capacitor C, forms a filter with R2 to suppress the leading edge switch spikes.

**OSCILLATOR SECTION**

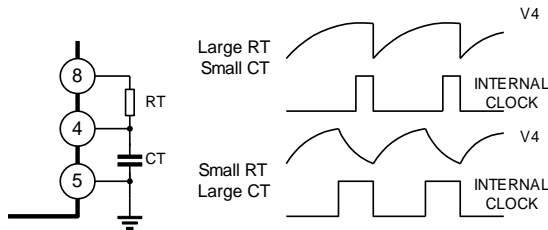

Deadtime VS  $C_T$  ( $R_T > 5k\Omega$ )

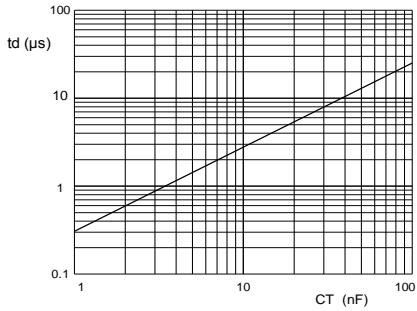

Timing Resistance Vs Frequency

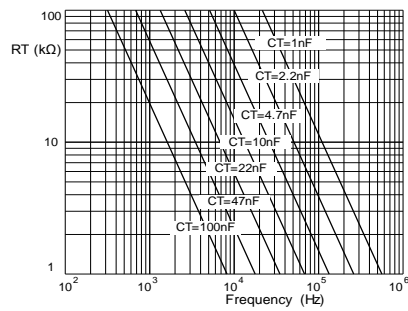

**SHUTDOWN TECHNIQUES**

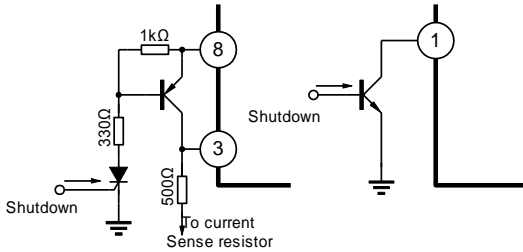

Shutdown UTC3843D/E can be accomplished by two methods; either raise pin 3 above 1V or pull Pin 1 below a voltage two diode drops above ground. Either method caused the output of PWM comparator to be high (refer to block diagram). The PWM latch is reset dominant so that the output will remain low until the next clock cycle after the shutdown condition at pins a and/or 3 is removed. In one example, an externally latched shutdown may be accomplished by adding an SCR which be reset by cycling  $V_{cc}$  below the lower UVLO threshold. At this point the reference turns off allowing the SCR to reset.

**TYPICAL PERFORMANCE CHARACTERISTICS**

Vref Temperature Drift

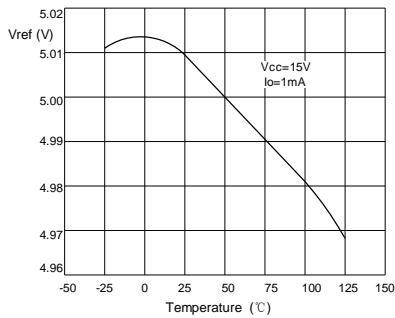

Istart Temperature Drift

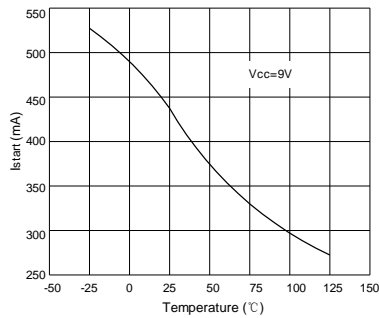

Icc Temperature Drift

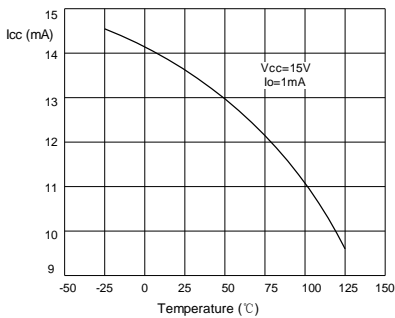

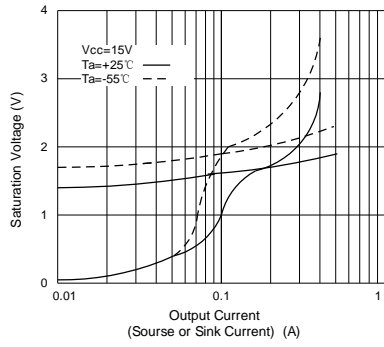

Output Saturation Characteristics

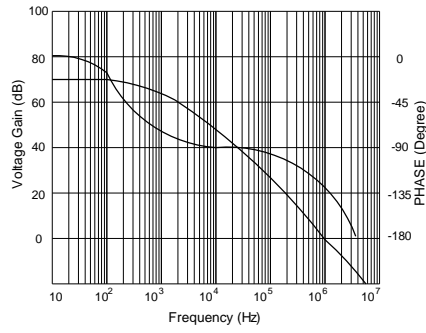

Error Amplifier Open-Loop Frequency Response

**PACKAGE DIMENSIONS**

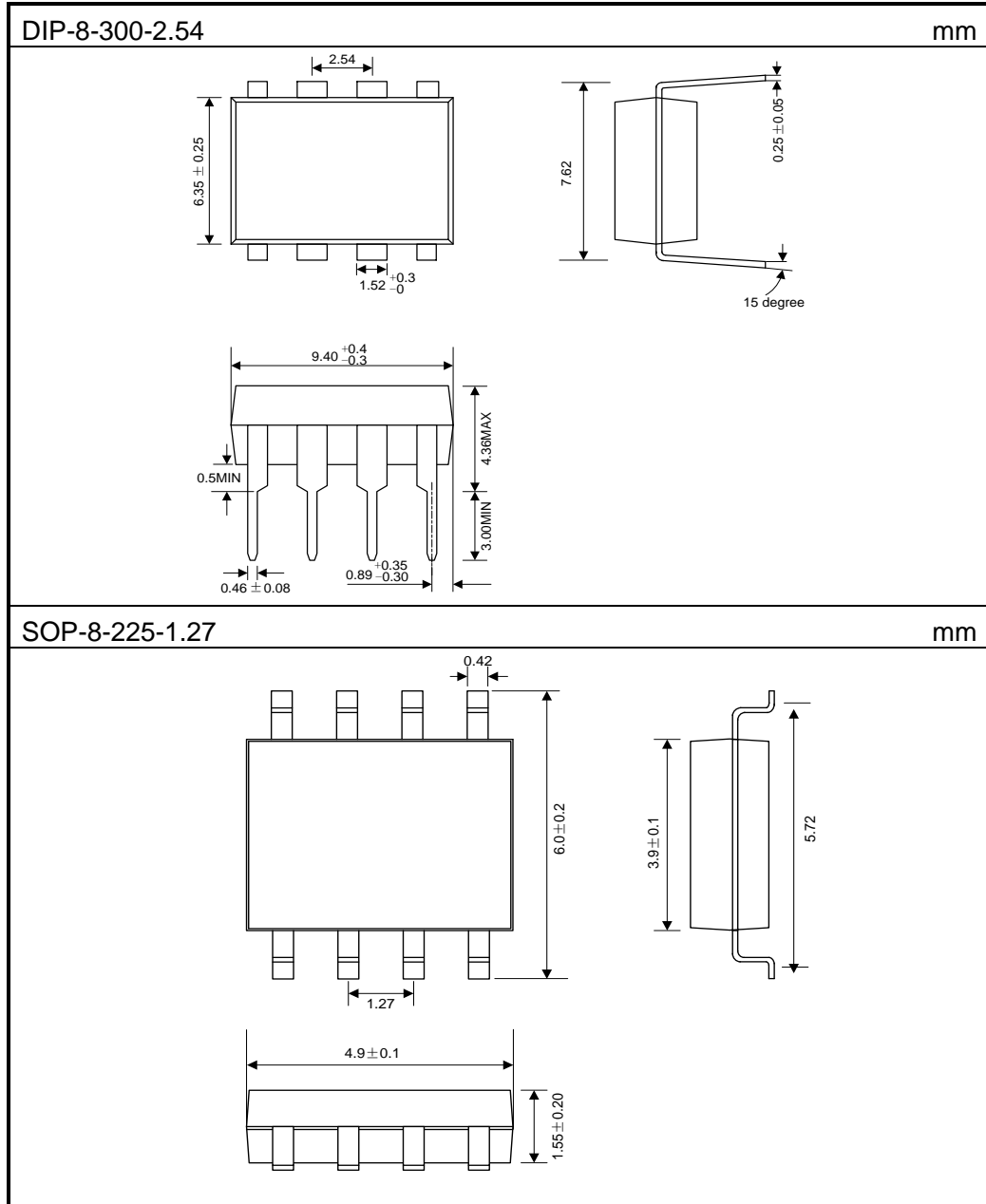



**ELECTROSTATIC DISCHARGE CAUTION**

These devices have limited built-in ESD protection. The leads should be shorted together or the device placed in conductive foam during storage handling to prevent electrostatic damage to the device.

**NOTICE**

HANGZHOU YOUWANG ELECTRONICS CO.LTD assumes no responsibility for equipment failures that result from using products at values that exceed, even momentarily, rated values (such as maximum ratings, operating condition ranges, or other parameters) listed in products specifications of any and all HANGZHOU YOUWANG ELECTRONICS CO.LTD's products described or contained herein. HANGZHOU YOUWANG ELECTRONICS CO.LTD's products are not designed for use in life support appliances, devices or systems where malfunction of these products can be reasonably expected to result in personal injury. Reproduction in whole or in part is prohibited without the prior written consent of the copyright owner. The information presented in this document does not form part of any quotation or contract, is believed to be accurate and reliable and may be changed without notice.

**Attach****Revision History**

<b>Data</b>	<b>REV</b>	<b>Description</b>	<b>Page</b>
	1.0	Original	
2006.07.11	1.1	Add "OREDRING INFORMATION" and package outline"SOP-8"	1,8
2017.08.21	1.2	Add "Electrostatic Discharge Caution" and "NOTICE"	

## X-ON Electronics

Largest Supplier of Electrical and Electronic Components

*Click to view similar products for [Switching Controllers](#) category:*

*Click to view products by [Youwang Electronics](#) manufacturer:*

Other Similar products are found below :

[LV5065VB-TLM-H](#) [LV5066V-TLM-H](#) [LV5725JAZ-AH](#) [633888R](#) [MP2908AGF](#) [AZ7500EP-E1](#) [NCP1012AP133G](#) [NCP1217P133G](#)  
[NCP1218AD65R2G](#) [NCP1234AD100R2G](#) [NCP1244BD065R2G](#) [NCP1336ADR2G](#) [NCP1587GDR2G](#) [NCP6153MNTWG](#)  
[NCP81005MNTWG](#) [NCP81101BMNTXG](#) [NCP81205MNTXG](#) [HV9123NG-G-M934](#) [IR35207MTRPBF](#) [ISL6367HIRZ](#) [CAT874-80ULGT3](#)  
[SJ6522AG](#) [SJE6600](#) [TLE63893GV50XUMA1](#) [IR35215MTRPBF](#) [SG3845DM](#) [NCP1216P133G](#) [NCP1236DD65R2G](#) [NCP1247BD100R2G](#)  
[NCP1250BP65G](#) [NCP4202MNR2G](#) [NCP4204MNTXG](#) [NCP6132AMNR2G](#) [NCP81141MNTXG](#) [NCP81142MNTXG](#) [NCP81172MNTXG](#)  
[NCP81203MNTXG](#) [NCP81206MNTXG](#) [NX2155HCUPTR](#) [UC3845ADM](#) [UBA2051C](#) [IR35201MTRPBF](#) [MAX8778ETJ+](#)  
[MAX17500AAUB+T](#) [MAX17411GTM+T](#) [MAX16933ATIR/V+](#) [NCP1010AP130G](#) [NCP1063AD100R2G](#) [NCP1216AP133G](#)  
[NCP1217AP100G](#)