

承认书

Cus t omer Name(客户名称):	
Description(品名)	防水轻触开关
Model(型号)	TS-1010-A6B3-D2
Cus t omer(客户料号)	

台湾元迪电子科技有限公司（投资、制造）
Taiwan yuan Di Electronic Technology Co.,ltd(Investment, manufacture)
Email:twyd@yuandicn.com
 全国统一客服热线:4006-383-895
ADD: No. 5 on Taiwan hsinchu science park of science and technology

泉州市元迪电子科技有限公司（产品研发、设计、制造）
Quanzhou yuan Di Technology Co., Ltd.(Product R & D, design, manufacture)
Email:qzyd@yuandicn.com
ADD: 26 Jinhuai Street, Fengze Street, Fengze District, Quanzhou City

东莞市元迪电子有限公司（销售、服务）
Dongguan YuDing Electronic Co.,Ltd(Sales, service)
TEL:+86-0769-87888890/82099668
FAX:+86-0769-87888891
Email:dgshela@yuandicn.com
ADD:东莞市塘厦镇第一工业区莲湖南路 68 号钜鸿创意园 A 栋

网站: <http://www.yuandicn.com>

批准人签名 Approver Signatures		
供应商确认签字 Supplier signature		
制定 formulate:	审核 Review:	批准 Approve:
邓达霖	陈海强	陈睿明
客户确认签字 Customer Signatures		
制定 formulate:	审核 Review:	批准 Approve:



元迪确认签名（盖章）
Yuan di confirm signature (seal)

RoHS

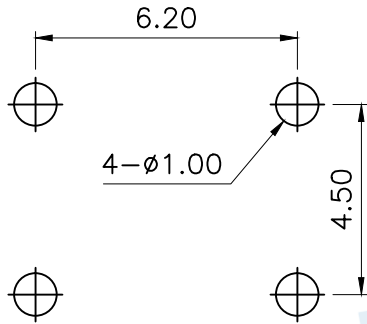
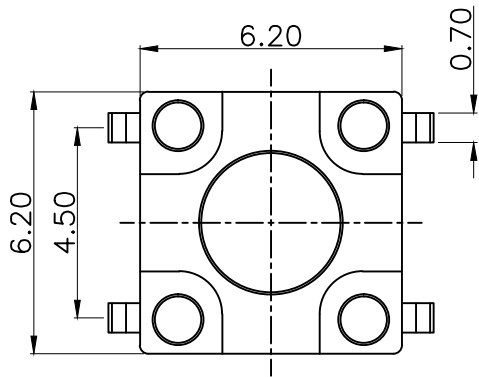

PCB Layout(Pattern side)

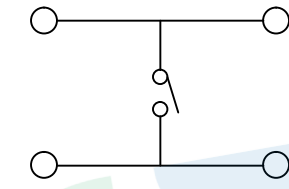

Circuit Diagram

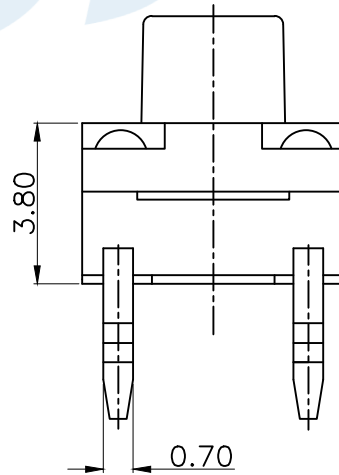
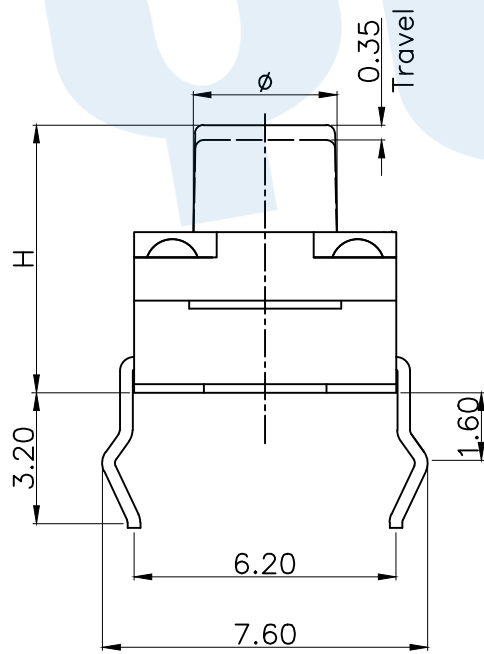
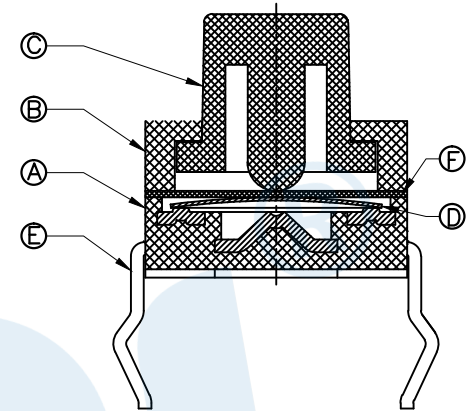

SHRAPNEL	
CODE	MATERIAL/QTY
D1	C5210/1PCS
D2	SUS/1PCS

OPERATING FORCE	
CODE	VIGOR
B2	180±50gf
B3	250±50gf
B4	350±50gf

TOTAL HEIGHT					
CODE	H	φ	CODE	H	φ
A1	4.3	3.5	A14	11	3.0
A2	4.5	3.5	A145	11.5	3.0
A3	5.0	3.5	A15	12	3.0
A4	5.5	3.5	A155	12.5	3.0
A5	6.0	3.5	A16	13	3.0
A6	6.5	3.3	A165	13.5	3.0
A7	7.0	3.3	A17	14	3.0
A8	7.5	3.3	A18	15	3.0
A9	8.0	3.3	A19	16	3.0
A10	8.5	3.3	A20	17	3.0
A11	9.0	3.1	A21	18	2.9
A12	9.5	3.1	A22	19	2.9
A13	10	3.1	A23	20	2.9
A135	10.5	3.0	A24	21	2.9

ⓕ	Waterproof mat	1	Silica gel	Black	
ⓔ	Terminal	4	Brass(0.3t)	Silvering	
ⓓ	Reed	1	SUS	Silver covered	
ⓒ	Button	1	PPA	Black	
ⓑ	Cover	1	PPA	Black	
Ⓐ	Base	1	PPA	Black	
NO.	Name	Number	Qty	Materil	Remarks

YUANDI® Yuandi Electronics Co, Ltd

design	date	name	TACT SWITCHS
Review	date	model	TS-1010-A□B□-D□
Approved	date		

Drawing number: Proportion 1:1 unit mm gage number A4

modify Review Approved Tolerance not specified

angle ±2'
10~30 ±0.30
5~10 ±0.20
~ 5 ±0.10

特色

- 高防尘防潮性 满足 IEC529 标准
- 高接触性 内部 A 触点圆形多点接触

开关导通模拟图

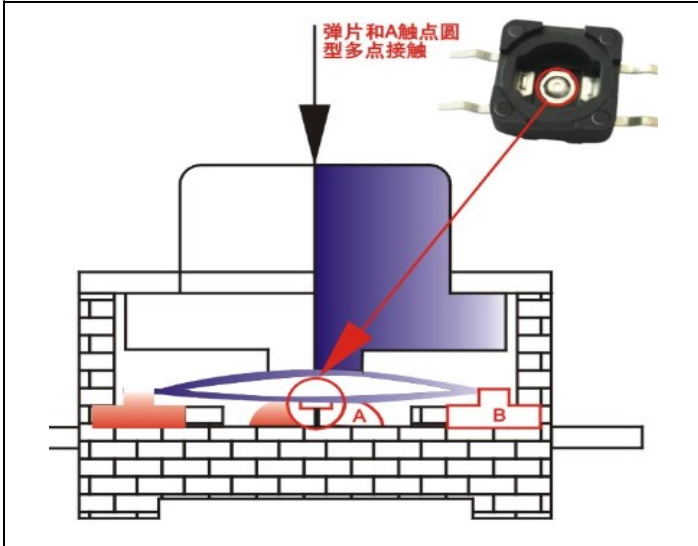

开关导通瞬间波形图

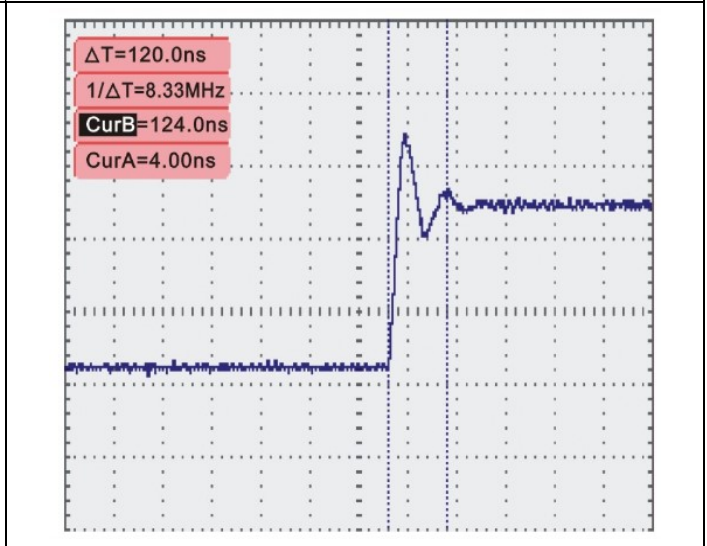

1.General 一般事项

1.1 Application 适用范围

This specification is applied to TACT switches which have no key-top
这是适用于常开状态下的通断开关的轻触开关.

1.2 Operating Temperature range 使用温度范围:

-40°C~90°C (normal humidity, normal air pressure 常湿 常压)

1.3 Storage Temperature range 保存温度范围:

-40°C~90°C (normal humidity, normal air pressure 常湿 常压)

1.4 Test condition 试验状态

Unless otherwise specified the atmospheric conditions for making measurements and tests are as follows
试验按以下标准状态规定执行

Normal temperature 常温 (temperature 温度 5~35°C)

Normal humidity 常湿 (Relative humidity 湿度 25%~85%)

Normal air pressure 常压 (Air pressure 气压 86~105KPa)

If any doubt arise judgement, tests shall be conducted at the following conditions

当判断出现疑问时, 可以采用以下测试条件

Ambient temperature 温度 20±2°C

Relative humidity 相对湿度 60%~70% Air pressure 气压 86~105KPa

标记 SIGN	处数 QUANTITY	更改文件号 FILENUMBER	签名 NAME	日期 DATE	标记 SIGN	处数 QUANTITY	更改文件号 FILENUMBER	签名 NAME	日期 DATE



2.Appearance,style and Dimension 外观、结构和尺寸

2.1 Appearance 外观

There shall be no defects that affect serviceability of the product.

不能有影响产品性能的不良外观出现

2.2 style and Dimension 结构和尺寸:

Refer to the assembly drawings 参照有关外形图.

3. Type of actuating 动作形式

Tactile feedback 按下自动弹回

4.Contact arrangement 回路形式

1 poles 1 throws 1 回路 1 接点

(Details of contact arrangement are given in the assemblydrawings 详见外形图)

5. Rating 电压

5.1 Maximum Rating 最大电压 12 V DC 50mA

5.2 Minimum Rating 最小电压 1 V DC 10UA

6. Electrical performance 电气性能

项目 Item		试验条件 Test conditions	规格参数 Requirements
6.1	Contact Resistance 接触电阻	Applying a beiw ststic load to the stem,measurements shall be made 施加荷重在按钮中间部位进行测定 (1) Depression 按压力: 500gf (2) Measuring method 测定方法: 1KHz small-current contact resistanc menter or voltage drop method at 5VDC 10mA 在 1KHz 微电流接触电阻计或 5VDC 10mA 电压下测试.	100mΩ Max.
6.2	Insulation resistance 绝缘电阻	Measurements shall be made following the test set forth below: 在以下条件下进行实验和测试 (1) Test voltage 施加电压 <u>100V</u> DC for 1min. (2)Applied postion 施加场所:Between all terminals.And if there is a metal frame,between terminals and ground(frame) 引脚之间或引脚和盖板\外壳间	100MΩ Min.
6.3	Voltage proof 耐压	Measurements shall be made following the test set forth below: 在以下条件下进行实验和测试 (1)Test voltage 施加电压 <u>250V</u> AC(50~60Hz) for 1min. (2)Applied postion 施加场所:Between all terminals.And if there is a metal frame,between terminals and ground(frame) 引脚之间或引脚和盖板\外壳间	There shall be no breakdown 无绝缘破坏

标记 SIGN	处数 QUANTITY	更改文件号 FILENUMBER	签名 NAME	日期 DATE	标记 SIGN	处数 QUANTITY	更改文件号 FILENUMBER	签名 NAME	日期 DATE
------------	----------------	---------------------	------------	------------	------------	----------------	---------------------	------------	------------



东莞市元迪电子有限公司
Dongguan YuDing Electronic Co.,Ltd

7. Mechanical performance 机械性能									
项目 Item		试验条件 Test conditions				规格参数 Requirements			
7.1	Operating force 按力	Placing the switch such that the direction of switch operation is vertical, and then gradually increasing the load applied to the center of the stem the maximum load for the Switch to come to a make"ON" shall be measured. 开关垂直于操作方向放置, 在按钮顶端中心逐渐施力, 测量开关导通所需的最大力度。				C: 250-310 gf			
7.2	Travel 行程	Placing the switch such that the direction of switch operation is vertical and then applying a below static load to the center of the stem the travel distance for the switch to come to a "ON" shall be measured.开关垂直于操作方向放置, 以一个等于 2 倍按力的静负荷施加于按钮顶端中心, 测量顶端的移动距离。				0.35±0.1mm			
7.3	Return force 回弹力	The sample switch is installed such that the direction of switch operation is vertical, and upon depression of stem in its center the whole travel distance, the force of the stem to return to its free position shall be measured.开关垂直于操作方向放置, 按钮顶端中心下降至全行程后, 测量顶端向自由位置返回的力度。				>49gf Min.			
7.4	Stop Strength 抗压强度	Placing the switch such that the direction of switch operation is vertical and then a below station load shall be applied in the direction of stem operation 在按钮顶端中央, 施加力于按压方向停止一段时间。 (1) Depression 按压力 <u>1000gf</u> (2)Time 时间 <u>15</u> s				There shall be no sign of damage mechanically abd electrically 无电气和机械性能的异常			
7.5	StemStrength 按钮拔去强度	Placing the switch such that the direction of switch operation is vertical and then the maximum force to withstand a pull applied opposite to the direction of stem operation shall be measured. 开关垂直于操作方向放置, 在按钮顶端中心逐渐施力和开关运动反方向的最大力。				3000gf Min.			
标记 SIGN	处数 QUANTITY	更改文件号 FILENUMBER	签名 NAME	日期 DATE	标记 SIGN	处数 QUANTITY	更改文件号 FILENUMBER	签名 NAME	日期 DATE

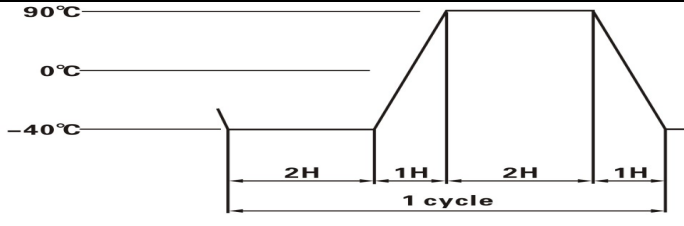
8. Environmental specification 耐气候性									
8.1	Resistance to low temperature 耐寒性	<p>Following the test set forth below the sample shall be left in normal temperature and humidity conditions for 2 h before measurements are made: 实验后常温常湿中放置 2 个小时后测定.</p> <p>(1) Temperature 温度: <u>-40</u> + <u>2</u> °C (2) Time 时间 <u>720h</u> Waterdrops shall be removed 清除水滴</p>	Item 6 Item 7.1 Item 7.2						
8.2	Heat resistance 耐热性	<p>Following the test set forth below the sample shall be left in normal temperature and humidity conditions for 2 h before measurements are made: 实验后常温常湿中放置 2 个小时后测定.</p> <p>(1) Temperature 温度: <u>90</u> + <u>2</u> °C Time 时间 <u>720h</u></p>	Item 6 Item 7.1 Item 7.2						
8.3	Moisture resistance 耐湿性	<p>Following the test set forth below the sample shall be left in normal temperature and humidity conditions for 2 h before measurements are made: 实验后常温常湿中放置 2 个小时后测定.</p> <p>(1) Temperature 温度: <u>60</u> + <u>2</u> °C (2) Time 时间 <u>240h</u> (3) Relative humidity 相对湿度 <u>90~95</u> % (4) Waterdrops shall be removed 清除水滴</p>	Contact resistance 接触电阻 (Item 6.1): <u>200</u> mΩ Insulation resistance 绝缘电阻 (Item 6.2): <u>10M</u> Ω Item 6.3 Item 7.1 Item 7.2						
8.4	Change of Temperature 耐高低温	<div style="text-align: center;">  </div> <p>After below cycles of following conditions, the switch shall be allowed to stand under normal room temperature and humidity conditions for 2 h, and measurement shall be made. water drops shall be removed. 在以上条件下循环 6 个实验后, 在常温常湿中放置 2 个小时后测定. 实验过程中清除水滴。</p>	Item 6 Item 7.1 Item 7.2						
8.5	Resistance to sulfide dioxide 耐硫化	<p>Following the test set forth below the sample shall be left in normal temperature and humidity conditions for 1 h before measurements are made: 实验后常温常湿中放置 1 个小时后测定.</p> <p>(1) Concentration of SO₂ gas. SO₂ 浓度 <u>10</u> ppm (2) Temperature 温度 <u>40</u> °C (3) Relative humidity 相对湿度 <u>75</u> % Time 时间 <u>120</u></p>	Contact resistance 接触电阻 (Item 6.1): <u>1</u> Ω						

标记 SIGN	处数 QUANTITY	更改文件号 FILENUMBER	签名 NAME	日期 DATE	标记 SIGN	处数 QUANTITY	更改文件号 FILENUMBER	签名 NAME	日期 DATE
------------	----------------	---------------------	------------	------------	------------	----------------	---------------------	------------	------------

9. Endurance specification 耐久性能

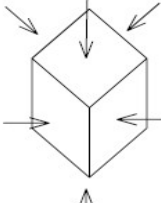
9.1	Operating life 寿命试验	Measurements shall be made following the test set forth below 在以下条件下进行试验和测试判断 (1) <u>12</u> VDC <u>50</u> mA resistive load 施加电压 (2) Rate of operation 动作速度: <u>1</u> to <u>2</u> operations per s 回/秒 (3) Depression 按压力 400gf Cycles of operation 动作回数 <u>100,000</u> cycles 回	Item 6 Item 7.1 Item 7.2 Operating force 按力(Item 7.1): <u>-30</u> ~ <u>+30</u> %of initial force 初始值						
9.2	Shock 耐冲击性	Measurements shall be made following the test set forth below 在以下条件下进行试验和测试判断 (1) Acceleration 加速度 <u>981</u> m/s ² (2) Action time 作用时间 6msec (3) Test direction 实验方向 6 directions 6 面 (4) Number of shecks 实验回数 <u>3</u> times per direction (<u>18</u> times in total)各方向个 3 回计 18 回) 	Item 6 Item 7.1 Item 7.2						
标记 SIGN	处数 QUANTITY	更改文件号 FILENUMBER	签名 NAME	日期 DATE	标记 SIGN	处数 QUANTITY	更改文件号 FILENUMBER	签名 NAME	日期 DATE

X-ON Electronics

Largest Supplier of Electrical and Electronic Components

Click to view similar products for [Tactile Switches](#) category:

Click to view products by [Yuandi](#) manufacturer:

Other Similar products are found below :

[5GTH92001](#) [5GTH9202242](#) [6407-250V-25273P](#) [ADTSA62NV](#) [ADTSA62RV](#) [B3F-3123](#) [1977177-8](#) [1977266-1](#) [ADTSA63NV](#)
[ADTSM21NSVTR](#) [ADTSM25RVTR](#) [ADTSM32NVTR](#) [ADTSMW64RV](#) [FSMRA4JHA04](#) [GS4.70F300QP](#) [3ESH9R](#) [KSC241J](#) [SP DELTA](#)
[LFS](#) [3FTL600RAS](#) [3FTL640RAS](#) [Y96K132V0FPLFS](#) [5GTH9658222](#) [ADTSM31NVTR](#) [2-1977120-7](#) [TSJW-5.2-260-TR](#)
[KMT011MNGJLHS](#) [70-201.0](#) [ADTSG648NV](#) [ADTSM62KSVTR](#) [ADTSM648NV](#) [95C06E3RAT](#) [5GTH96561](#) [3ATH9Q](#) [FSM4JSMLXTR](#)
[FSM4JSMXL](#) [FSMRA8JHA04](#) [HARS0073](#) [Y97HS12A5RAFP](#) [Y97BT23B2HAFP](#) [Y33R411N9FPLFT](#) [Y31C01402FPLFS](#)
[PTS645SK50SMTR92](#) [ADTSM32NVB](#) [KMS233GPWTLFG](#) [Y78B42324FP](#) [Y33R21116FPLFT](#) [Y31B43131FPLFG](#) [Y78B64124FP](#)
[Y71243251FP](#) [Y33R31119FPLFT](#) [Y97HS12A5TAFP](#)