

AZDC105

DC HIGH CURRENT POWER RELAY

FEATURES

- 150A 60VDC / 100A 60VDC / 100A 48VDC switching capability
- Magnetic arc blow-out design
- 4 kV dielectric strength, 6 kV surge withstand voltage
- UL Class F insulation (155°C)
- UL / CUR file E44211
- TÜV R50394622



Illustration similar

CONTACTS

Arrangement	SPST-N.O. (1 Form A)
Ratings (max.)	(resistive load) switched power 9000 W / 6000W / 4800 W switched current 100 A / 150 A switched voltage 48 VDC / 60 VDC
Rated Loads	100/150 A at 48/60 VDC, resistive, 85°C, 10k cycles
UL/CUR	
TÜV	48 VDC versions rated load, resistive, 3k cycles 60 VDC versions rated load, resistive, 1k cycles
Contact material	AgSnO ₂ (silver tin oxide)
Contact gap	≥ 3.0 mm
Initial resistance	≤ 100 mΩ (1 A / 6 V - voltage drop method)

COIL

Nominal coil DC voltages	see coil voltage specifications table
Dropout voltage	≥ 5% of nominal coil voltage
Coil power	nominal 3.2 W at pickup voltage 1.8 W (typ.)
Temperature Rise	50 K (90°F) at nominal coil voltage
Max. temperature	Class F insulation - 155°C (311°F)

NOTES

1. All values at 20°C (68°F).
2. Relay may pull in with less than "Must Operate" value.
3. These relays are equipped with permanent magnets. This has to be taken into account during handling and assembly of the components.
4. Provide sufficient PCB cross section on load terminals.
Recommended wiring cross section according to IEC 61810-1:2015:
35 mm² for 100 A versions, 50 mm² for 150 A versions.
5. Specifications subject to change without notice.

GENERAL DATA

Life Expectancy	(minimum operations)
mechanical	1 x 10 ⁶
electrical	(360 cycles/h, 10 % duty factor)
48 VDC versions	3 x 10 ³ at rated loads
60 VDC versions	1 x 10 ³ at rated loads
Operate Time	30 ms (max.) at nominal coil voltage
Release Time	10 ms (max.) at nominal coil voltage, without coil suppression
Dielectric Strength	(at sea level for 1 min.) 4000 V _{RMS} coil to contact 1300 V _{RMS} between open contacts
Surge Voltage	coil to contact 6 kV (at 1.2 x 50 μs)
Insulation	resistance 1000 MΩ (min.) at 20°C, 500 VDC, 50% RH III pollution degree 2
Creepage	coil to contact ≥ 9.0 mm
Clearance	coil to contact ≥ 9.0 mm
Operating Temp. Range	(at nominal coil voltage) 100 A versions -40°C (-40°F) to 85°C (185°F) 150 A versions -40°C (-40°F) to 65°C (149°F)
Vibration resistance	0.062" (1.5 mm) DA at 10–55 Hz
Shock resistance	10 g
Enclosure	RTII - flux proof (vented) P.B.T. polyester, UL94 V-0
Terminals	Tinned copper alloy, P. C.
Soldering	max. temperature 270 °C (518°F) max. time 5 seconds
Cleaning	max. solvent temp. 80°C (176°F) max. immersion time 30 seconds
Dimensions	length 47.6 mm (1.874") width 40.0 mm (1.575") height 45.1 mm (1.776")
Weight	165 grams (approx.)
Packing unit in pcs	25 per tray / 50 per carton box
Compliance	UL 508, IEC 61810-1, RoHS, REACH

ZETTLER electronics GmbH - A ZETTLER GROUP Company

Junkersstr. 3, D-82178 Puchheim, Germany

phone: +49 89 800 97-0
fax: +49 89 800 97-200

office@ZETTLERelectronics.com
www.ZETTLERelectronics.com

This product specification is to be used only together with the application notes which can be downloaded from www.ZETTLERelectronics.com/pdfs/relais/ApplicationNotes.pdf

AZDC105

COIL VOLTAGE SPECIFICATIONS

Nominal Coil VDC	Must Operate VDC	Resistance Ohm $\pm 10\%$
12	9.0	45
24	18.0	180
48	36.0	720

ORDERING DATA

AZDC105-1A - D

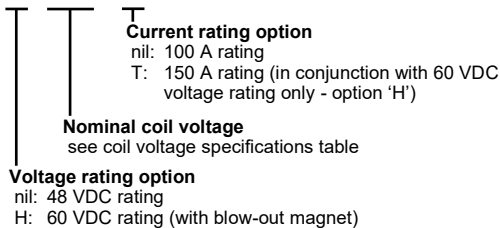

Example ordering data

AZDC105-1A-12D	100 A 48 VDC contact rating, 12 VDC nom. coil voltage
AZDC105-1AH-24D	100 A 60 VDC contact rating, 24 VDC nom. coil voltage
AZDC105-1AH-24DT	150 A 60 VDC contact rating, 24 VDC nom. coil voltage

MECHANICAL DATA

Dimensions in mm. Outline tolerance: ± 0.5 mm

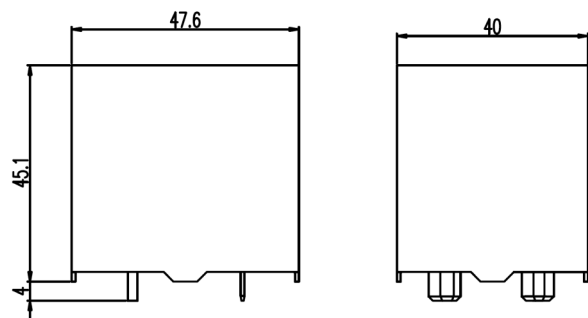

PC BOARD LAYOUT

Dimensions in mm. Tolerance: ± 0.1 mm
 Viewed towards terminals.

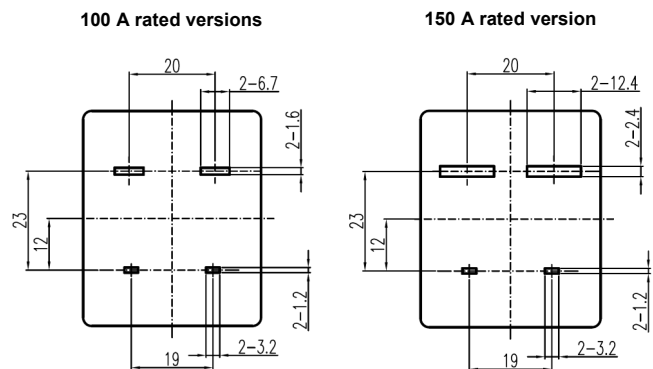

WIRING DIAGRAMS

Viewed towards terminals.

Notes: The 60 VDC rated versions are polarized. Observe polarity of load contacts and coil as shown in the diagram.

Provide sufficient PCB cross section on load terminals. Recommended cross section according to IEC 61810-1: 35 mm² for 100 A versions, 50 mm² for 150 A versions.

48 VDC rated version

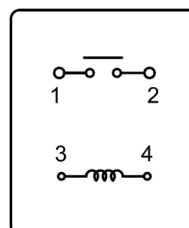

60 VDC rated versions

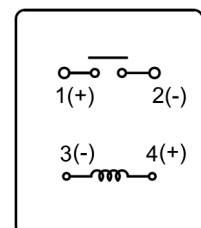

ZETTLER electronics GmbH - A ZETTLER GROUP Company

Junkersstr. 3, D-82178 Puchheim, Germany

phone: +49 89 800 97-0
 fax: +49 89 800 97-200

office@ZETTLERelectronics.com
 www.ZETTLERelectronics.com

This product specification is to be used only together with the application notes which can be downloaded from www.ZETTLERelectronics.com/pdfs/relais/ApplicationNotes.pdf

X-ON Electronics

Largest Supplier of Electrical and Electronic Components

Click to view similar products for [General Purpose Relays](#) category:

Click to view products by [Zettler](#) manufacturer:

Other Similar products are found below :

[PCN-105D3MH,000](#) [59641F200](#) [5JO-1000CD-SIL](#) [5X827E](#) [5X837F](#) [5X840F](#) [5X842F](#) [5X848E](#) [LY2N-AC120](#) [LY2-US-AC120](#) [LY2-US-DC24](#) [LY3-US-AC120](#) [LY4F-UA-DC12](#) [LY4F-UA-DC24](#) [LY4F-US-AC120](#) [LY4F-US-AC240](#) [LY4F-US-DC24](#) [LY4F-VD-AC110](#)
[M115C60](#) [M115N010](#) [M115N0150](#) [603-12D](#) [60HE1-5DC](#) [60HE2S-12DC](#) [61211T0B4](#) [61212T400](#) [61222Q400](#) [61243B600](#) [61243C500](#)
[61243Q400](#) [61311BOA2](#) [61311BOA6](#) [61311BOA8](#) [61311C0A2](#) [61311COA1](#) [61311COA6](#) [61311F0A2](#) [61311QOA1](#) [61311QOA4](#)
[61311T0D6](#) [61311TOA6](#) [61311TOA7](#) [61311TOB3](#) [61311TOB4](#) [61311U0A6](#) [61312Q600](#) [61312T400](#) [61312T600](#) [61313U200](#) [61313U400](#)