

SPECIFICATION

Type: HRS1H-S-DC12V Relay

1. 线圈参数

| | |
|------------|-------------------------------|
| 1.1 额定电压 | 12VDC. |
| 1.2 线圈电阻 | 720 Ω \pm 10% at 23. |
| 1.3 额定电流 | 16.7mA \pm 10% at 23. |
| 1.4 吸合电压 | 9.0VDC Max. |
| 1.5 释放电压 | 1.2VDC Min. |
| 1.6 最大线圈电压 | 15.6VDC(130%额定电压) |
| 1.7 额定功耗 | 200mW |

2. 触点参数

| | |
|----------------|--|
| 2.1 触点形式 | 1 Form C-SPDT |
| 2.2 触点材质 | Au Ag |
| 2.3 触点负载 | Resistive: 1A 120VAC/24VDC |
| 2.4 最大切换电压 | 30VDC / 220VAC |
| 2.5 最大切换电流 | 3A |
| 2.6 最大切换功率 | 360VA, 90W |
| 2.7 最小切换电流电压 | 10mA 5VDC |
| 2.8 接触电阻 (初始值) | Max.50m Ω at 6VDC 0.1A |
| 2.9 电气耐久性 | 常温下 100,000 次 (1800 ops/h) 试验后,介质耐压值应不小于初始值的 75%。 |
| 2.10 机械耐久性 | 空载条件下 10,000,000 次(18,000 ops/h) |

3. 其他性能

| | |
|--------------------|---|
| 3.1 绝缘电阻 | Min.100M Ω at 500VDC |
| 3.2 介质耐压(漏电流: 1mA) | |
| (1) 触点间 | 750VAC, 1 min , 50/60Hz |
| (2) 触点与线圈间 | 1,000VAC, 1 min , 50/60Hz |
| 3.3 吸合时间 | Max. 5 ms. |
| 3.4 释放时间 | Max. 5 ms. |
| 3.5 工作温度 | -40 to +70 $^{\circ}$ C |
| 3.6 储存条件 | |
| (1) 储存温度 | -40 to +85 $^{\circ}$ C |
| (2) 环境 | 贮存于无腐蚀性气体的场所, 如硫化氢气体或有盐份的空气中。 贮存于产品不受阳光直射的场所, 不受雨淋的场所。 |

- 3.7 温升
线圈 在 85℃环境温度下，触点施加 1A 负载，线圈用 110%额定电压进行激励，用电阻法测线圈温升应不超过 40K。
- 3.8 端子强度
拉力和推力 继电器结构和性能应无任何异常当用1kg的拉力和推力推拉继电器端子10s。
- 3.9 可焊性 在锡温为 260±5℃的锡炉中浸渍 5±1s，端子应有 95%区域被锡覆盖。
- 3.10 耐焊接热 在锡温为 260±5℃的锡炉中浸渍 10±1s 后将继电器在常温常湿下恢复 1.5 小时，继电器结构和性能应无任何异常。如果是手工焊锡，必须在 350±10℃的锡温下浸渍 3.5±0.5s 。
接触电阻应小于 100m Ω。
- 3.11 寒冷 继电器在-40±3℃温度下放置 2 小时后将其在常温常湿下恢复 1.5 小时，继电器结构和性能应无任何异常。
接触电阻应小于 100m Ω。
- 3.12 干热 继电器在 85±2℃温度下放置 16 小时后将其在常温常湿下恢复 1.5 小时，继电器结构和性能应无任何异常。
接触电阻应小于 100m Ω。
- 3.13 耐湿热 继电器在 90-95% RH 湿度，40±2℃温度下放置 48 小时后将其在常温常湿下恢复 1.5 小时，继电器结构和性能应无任何异常。
绝缘电阻应不小于 10 M ohms，接触电阻应小于 100m Ω。
- 3.14 振动
(1) 强度 继电器在 1.5 mm 双振幅，10~55~10Hz 的频率下每个方向（X、Y、Z）振动 2h，共 6h，继电器结构和性能应无任何异常
- (2) 稳定性
(激励) 触点打开时间不超过 1ms 或更长时间当继电器在 1.5 mm 双振幅，10~55~10Hz 的频率下每个方向（X、Y、Z）经受 5 分钟的振动，共 30 分钟。
- 3.15 冲击
(1) 强度 继电器在 1,000m/s²加速度，时间为 6ms 的条件下每个方向（X、Y、Z）经受 3 次冲击，共 18 次冲击，继电器结构和性能应无任何异常
- (2) 稳定性
(激励) 触点打开时间不超过 1ms 或更长时间当继电器在 100m/s²加速度，时间为 11ms 的条件下每个方向（X、Y、Z）经受 3 次冲击，共 18 次冲击。

- 4 命名:
HRS1 H - S - DC12V
a b c d
a: 继电器系列号
b: 线圈功率
H 表示功率为 200mW
c: 封胶型式
S: 塑封型
d: 线圈电压 DC12V
- 5 印字
印字图号 Y-HRS1-N9
外壳颜色 黄色
印字类型 激光印字
- 6 外形尺寸, 安装脚位, 接线图 图号. HKE4.520.025
- 7 安全认证
UL NO.E164730
TUV NO. 50103498
CQC12002086133

Y-HRS1-N9



图1 1:1



图2 2.5:1

表 1

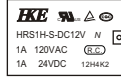
| HRS1 | H | S | DC12V |
|------|------------------------------|---------------|---------------------|
| 型号 | 线圈功率 无: 360mW H: 200mW | 密封性 S: 塑封型 | 线圈电压: DC3V—DC24V |

表 2

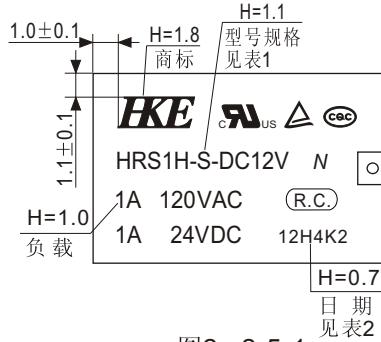
| | | | | |
|----|--|---|-------|---|
| 12 | H | 4 | K | 2 |
| 年份 | 月份: A:1月 E:5月 I:9月 B:2月 F:6月 J:10月 C:3月 G:7月 K:11月 D:4月 H:8月 L:12月 | 星期: 1:第1星期 2:第2星期 3:第3星期 4:第4星期 | MAKER | 分部编码: 1: 生产一部, 2: 生产二部 3: 生产三部, 5: 生产五部 6: 生产六部, 7: 生产七部 8: 生产八部, 9: 生产九部 |

技术要求:

- 1.此为HRS1新结构产品的印字;
- 2.未注公差按±0.2,以上单位为mm;
- 3.单线印字, 线条、字迹应清晰、美观。

产品编号

HRS1

旧底图总号

标记 数量 更改单号 签名 日期

底图总号

日期 签名

设计
审核
工艺
标准化
批准

HRS1外壳标志图
HRS1 Marking



浙江汇港电器有限公司

阶段 标记 质量 比例

共 页 第 页

Y-HRS1-N9

HKE4.520.025

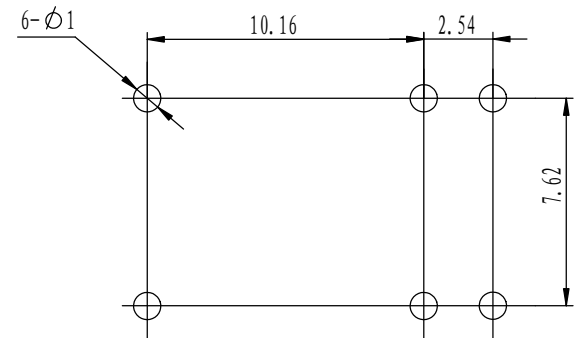
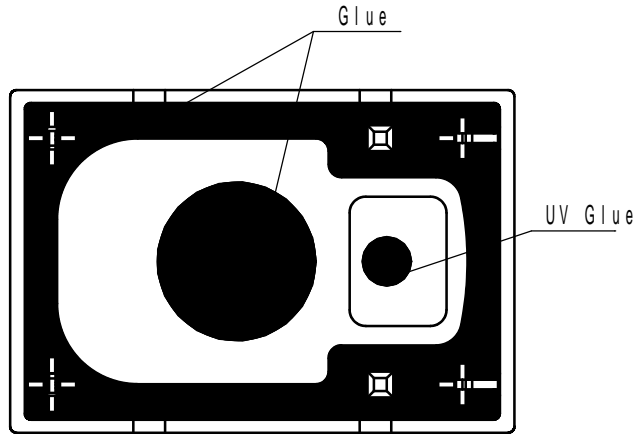

PC board layouts (Bottom View)

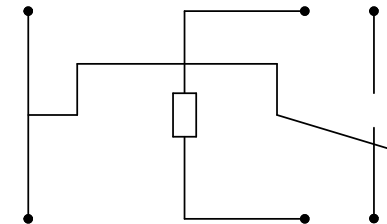
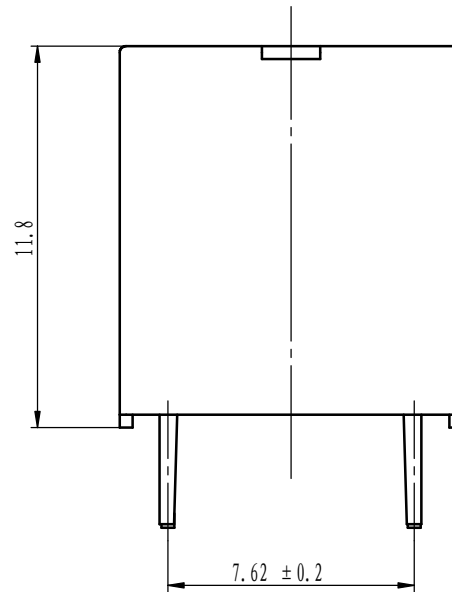
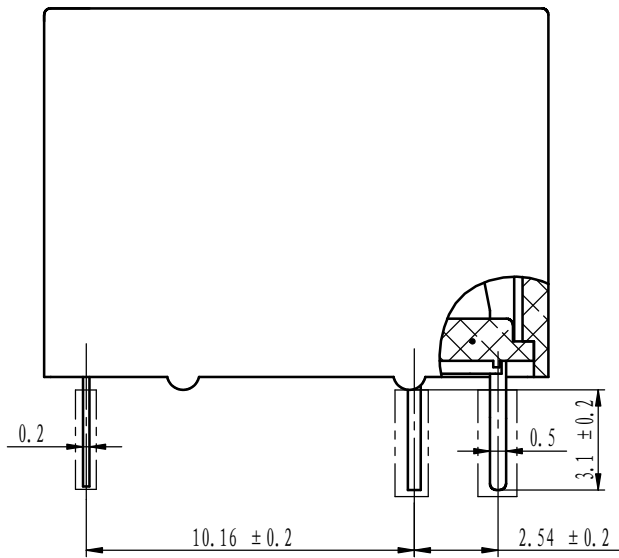

Wiring Diagram (Bottom View)

媒体编号

旧底图总号

底图总号

日期

签名

格式 (1)

制图:

HRS1-C Relay

HKE4.520.025

| 阶段 | 标记 | 质量 | 比例 |
|----|----|----|----|
| | | | |

第 张 共 张

EKE
浙江汇港电器有限公司

描图:

幅面: A4



质量管理体系认证证书

证书编号: 00111Q26542R4M/3302

兹证明
浙江汇港电器有限公司

中国浙江省宁波市鄞州区云龙镇甲村(架山)162号

建立的质量管理体系符合标准:

ISO9001:2008

GB/T 19001-2008

通过认证范围如下:

电磁继电器的设计、组装生产和服务

首次发证日期: 2008年8月15日 本次发证日期: 2011年8月9日 有效期至: 2014年8月8日

在一个监督周期后, 本证书必须与CQC签发的监督审核合格通知书合并使用方可有效。查询证书有效状态请登陆www.cqc.com.cn。



Signed by: Wang Kejiao



中国质量认证中心

中国·北京·南四环西路188号9区 100070
<http://www.cqc.com.cn>

Q 0070390

2009年版



环境管理体系认证证书

证书编号: 00112E21299R3M/3302

兹证明

浙江汇港电器有限公司

中国浙江省宁波市鄞州区云龙镇甲村(架山)162号

建立的环境管理体系符合标准:

ISO14001:2004

GB/T 24001-2004

通过认证范围如下:

电磁继电器的设计、生产及相关管理活动

首次发证日期: 2003年12月3日 本次发证日期: 2012年7月3日 有效期至: 2015年7月2日

在一个监督周期后, 本证书必须与CQC签发的监督审核合格通知书合并使用方可有效。查询证书有效状态请登陆www.cqc.com.cn。



Signed by: Wang Kejiao



中国质量认证中心

中国·北京·南四环西路188号9区 100070
<http://www.cqc.com.cn>

E 0012844

2009年版



NRNT2.E164730 Switches, Industrial Control - Component

[Page Bottom](#)

Switches, Industrial Control - Component

[See General Information for Switches, Industrial Control - Component](#)

ZHEJIANG HKE RELAY CO LTD

E164730

28 JIA CUN INDUSTRY AREA
NINGBO, ZHEJIANG 315135 CHINA

Relays, Model(s) AC, followed by 3, followed by S, followed by DC, followed by 5V, 6V, 9V, 12V, 18V or 24V, followed by A

Relays, Model(s) CMP6-S or F6-S, followed by DC5V, 6V, 9V, 12V, or 24V, may be followed by P

Relays, Model(s) CMP7 or CMP8, followed by Nil or S, followed by DC5V, DC6V, DC24V, DC9V, DC12V, DC24V, DC48V, followed by A or C

Relays, Model(s) CMP8(AT)-S followed by DC5V, DC6V, DC9V, DC12V, DC24V or DC48V, followed by A

Relays, Model(s) HCP, followed by 1, 2 or 3, followed by blank or S, followed by DC, followed by 5V, 6V, 9V, 12V, 18V, 24V, 36V, 48V, followed by A or C, HRA, may be followed by H, may be followed by S, HRB1-S, followed by DC3V, DC5V, DC6V, DC9V, DC12V or DC24V, HRM, may be followed by 1 or 2, may be followed by H, may be followed by S

Relays, Model(s) HRM, may be followed by 3, may be followed by H or L, may be followed by S, may be followed by DC3-DC48, may be followed by T.

Relays, Model(s) HRM4, may be followed by H, may be followed by S, followed by DC3-DC24 incl

Relays, Model(s) HRM4, may be followed by H, may be followed by S, may be followed by DC3 - DC48, followed by SP, HRMF, followed by DC3V, DC5V, DC6V, DC9V, DC12V, DC18V, DC24V or DC48V

Relays, Model(s) HRS, may be followed by 3 or 4, may be followed by H, may be followed by A, may be followed by S, followed by DC3-D48 incl

Relays, Model(s) HRS1, may be followed by K, may be followed by B or H, may be followed by 3, may be followed by S, followed by DC, followed by XX, where XX is coil voltage, HRS2, may be followed by B or H, may be followed by S

Relays, Model(s) HRS2H, followed by S, followed by 3 VDC through 48 VDC, may be followed B, N or T

Relays, Model(s) HRS3, may be followed by N, may be followed by H, followed by S, followed by DC3V, DC5V, DC6V, DC9V, DC12V, or DC24V, may be followed by A or C

Relays, Model(s) HRS3-S, followed by DC3V, DC5V, DC6V, DC9V, DC12V or DC24V, followed by A or C

Relays, Model(s) HRS3T, may be followed by N, may be followed by H, followed by S, followed by DC, followed by 3V, 5V, 6V, 9V, 12V or 24V, followed by A or C

Relays, Model(s) HRS4, may be followed by T, may be followed by F, may be followed by H, followed by S, followed by DC, followed by 3V, through 60V may be followed by A

Relays, Model(s) HRS4E, followed by by Blank or H; followed by Blank or S; followed by DC3V, DC5V, DC6V, DC9V, DC12V, DC18V, DC24V or DC48V; followed by X or G

Relays, Model(s) L7, may be followed by S, followed by DC6V, DC12V, DC24V, DC48V, DC100V, DC110V, AC6V, AC12V, AC24V, AC48V, AC100V, AC120V, AC220V, AC240V, followed by 1A or 2A, followed by 2P or 2Q

Relays, Model(s) V6, may be followed by S, followed by DC3V, DC5V, DC6V, DC9V, DC12V, DC18V, DC24V or DC48V

Relays, open type, Model(s) AC5, may be followed by N, may be followed by S, followed by DC, followed by 5V, 6V, 9V, 12V, 18V or 24V

Relays, open type, Model(s) F5, may be followed by H, followed by DC, followed by 3V, 5V, 6V, 9V, 12V, 18V, 24V or 48V, followed by P1,P2 or P3

Relays, open type, Model(s) HCP4, may be followed by S, followed by DC, followed by 5V, 6V, 9V, 12V, 18V, 24V, 36V, or 48V, followed by A or C.

Relays, open type, for use in industrial application, Model(s) LH-DC12V-Q-2C

Marking: Company name or tradename "E164730" or trademark  and model designation.
Last Updated on 2010-01-10

[Questions?](#)

[Notice of Disclaimer](#)

[Page Top](#)

[Copyright ?2010 Underwriters Laboratories Inc.®](#)

The appearance of a company's name or product in this database does not in itself assure that products so identified have been manufactured under UL's Follow-Up Service. Only those products bearing the UL Mark should be considered to be Listed and covered under UL's Follow-Up Service. Always look for the Mark on the product.

UL permits the reproduction of the material contained in the Online Certification Directory subject to the following conditions: 1. The Guide Information, Designs and/or Listings (files) must be presented in their entirety and in a non-misleading manner, without any manipulation of the data (or drawings). 2. The statement "Reprinted from the Online Certifications Directory with permission from Underwriters Laboratories Inc." must appear adjacent to the extracted material. In addition, the reprinted material must include a copyright notice in the following format: "Copyright © 2010 Underwriters Laboratories Inc.®"

An independent organization working for a safer world with integrity, precision and knowledge.



Zertifikat

Certificate



Zertifikat Nr. *Certificate No.*
R 50103498

Blatt *Page*
0001

Ihr Zeichen *Client Reference*
L.Y.H.

Unser Zeichen *Our Reference*
ZC10-HJA- 14702151 001

Ausstellungsdatum
12.09.2007

Date of Issue
(day/mo/yr)

Genehmigungsinhaber *License Holder*
Zhejiang HKE Relay Co., Ltd.
28 Jiacun Industry Area
Ningbo, Zhejiang 315135
P.R. China

Fertigungsstätte *Manufacturing Plant*
Zhejiang HKE Relay Co., Ltd.
28 Jiacun Industry Area
Ningbo, Zhejiang 315135
P.R. China

Prüfzeichen *Test Mark*

Geprüft nach *Tested acc. to*
EN 61810-1:2004



Zertifiziertes Produkt *(Geräteidentifikation)*
Certified Product (Product Identification)

Lizenzentgelte - Einheit
License Fee - Unit

Relais (Relay)

Type Designation : HRS1xy-S-z 5
x = K or Blank 1
y = H or Blank 1
z = DC3V; DC5V; DC6V; DC9V; 1
DC12V or DC24V 1

Rated Coil Voltage : DC 3V; 5V; 6V; 9V; 12V or 24V
Rated Coil Power : 0.2W or 0.36W
Ambient Temperature : -25°C to +70°C
Contact Rating : 1A 120VAC
1A 24VDC

Number of Cycles for
Electrical Endurance : 50,000

Continued on page 0002



8

ANLAGE (Appendix) : 1

*Dem Zertifikat liegt unsere Prüf- und Zertifizierungsordnung zugrunde.
Das Produkt entspricht den o.g. Anforderungen, die Herstellung wird überwacht.
This certificate is based on our Testing and Certification Regulation. The product
fulfills above mentioned requirements, the production is subject to surveillance.*

Zertifizierungsstelle

TÜV Rheinland Product Safety GmbH, Am Grauen Stein, D-51105 Köln
Tel.: (+49/221)8 06 - 13 71 e-mail: cert-validity@de.tuv.com
Fax: (+49/221)8 06 - 39 35 http://www.tuv.com/safety

Dipl.-Ing. J. Rossow

Zertifikat

Certificate



Zertifikat Nr. *Certificate No.*
R 50103498

Blatt *Page*
0002

Ihr Zeichen *Client Reference*
L.Y.H.

Unser Zeichen *Our Reference*
ZC10-HJA- 14702151 001

Ausstellungsdatum
12.09.2007

Date of Issue
(day/mo/yr)

Genehmigungsinhaber *License Holder*
Zhejiang HKE Relay Co., Ltd.
28 Jiacun Industry Area
Ningbo, Zhejiang 315135
P.R. China

Fertigungsstätte *Manufacturing Plant*
Zhejiang HKE Relay Co., Ltd.
28 Jiacun Industry Area
Ningbo, Zhejiang 315135
P.R. China

Prüfzeichen *Test Mark*



Geprüft nach *Tested acc. to*
EN 61810-1:2004

Zertifiziertes Produkt (Geräteidentifikation)
Certified Product (Product Identification)

Lizenzentgelte - Einheit
License Fee - Unit

Relais (Relay)

Continuation

Number of Cycles for
Mechanical Endurance : 10,000,000
Thermal Insulation Class : F
Type of Interruption : Micro-disconnection
Insulation System between
Coil and Contact : Basic Insulation

Remark: The certified products also comply with Annex ZE of
EN 60730-1:2000+A1+A12+A13+A14+A15+A16 in addition
to above mentioned standard.

The labelling requirements acc. to EU Directive 2001/95
have to be observed for distribution within the EEA.

ANLAGE (Appendix): 1

Dem Zertifikat liegt unsere Prüf- und Zertifizierungsordnung zugrunde.
Das Produkt entspricht den o.g. Anforderungen, die Herstellung wird überwacht.
This certificate is based on our Testing and Certification Regulation. The product
fulfills above mentioned requirements, the production is subject to surveillance.

Zertifizierungsstelle

TÜV Rheinland Product Safety GmbH, Am Grauen Stein, D-51105 Köln
Tel.: (+49/221)8 06 - 13 71 e-mail: cert-validity@de.tuv.com
Fax: (+49/221)8 06 - 39 35 http://www.tuv.com/safety

Dipl.-Ing. J. Rossow



Zertifikat

Certificate



Zertifikat Nr. *Certificate No.*
R 50103498

Blatt *Page*
0003

| <i>Ihr Zeichen Client Reference</i> | <i>Unser Zeichen Our Reference</i> | <i>Ausstellungsdatum</i> | <i>Date of Issue</i> <i>(day/mo/yr)</i> |
|-------------------------------------|------------------------------------|--------------------------|--|
| L.Y.H. | ZC10-HJA- 14702151 003 | 24.08.2011 | |

Genehmigungsinhaber *License Holder*
Zhejiang HKE Relay Co., Ltd.
28 Jiacun Industry Area
Ningbo, Zhejiang 315135
P.R. China

Fertigungsstätte *Manufacturing Plant*
Zhejiang HKE Relay Co., Ltd.
28 Jiacun Industry Area
Ningbo, Zhejiang 315135
P.R. China

Prüfzeichen *Test Mark*

Geprüft nach *Tested acc. to*
EN 61810-1:2008

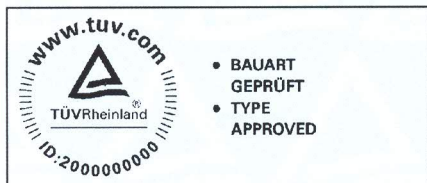

Zertifiziertes Produkt (Geräteidentifikation)
Certified Product (Product Identification)

Lizenzentgelte - Einheit
License Fee - Unit

Relais (Relay)

as page 0001-0002

Change

Test Requirement: See above

Remark: Appendix 1 issued on 05/09/2007 was replaced by
Appendix 1 issued on 22/08/2011.

Dem Zertifikat liegt unsere Prüf- und Zertifizierungsordnung zugrunde und es bestätigt die Konformität des Produktes mit den oben genannten Standards und Prüfgrundlagen. Zusätzliche Anforderungen in Ländern, in denen das Produkt in Verkehr gebracht werden soll, müssen zusätzlich betrachtet werden. Die Herstellung des zertifizierten Produktes wird überwacht.
This certificate is based on our Testing and Certification Regulation and states the conformity of the product with the standards and testing requirements as indicated above. Any additional requirements in countries where the product is going to be marketed have to be considered additionally. The manufacturing of the certified product is subject to surveillance.

TÜV Rheinland LGA Products GmbH - Tillystraße 2 - 90431 Nürnberg
Tel.: (+49/221)8 06 - 13 71 e-mail: cert-validity@de.tuv.com
Fax: (+49/221)8 06 - 39 35 http://www.tuv.com/safety

Zertifizierungsstelle

James Li





PRODUCT CERTIFICATE

No.: CQC12002086133

NAME AND ADDRESS OF THE APPLICANT

ZHEJIANG HKE RELAY CO., LTD
JIACUN INDUSTRY AREA 28, NINGBO ZHEJIANG 315135

NAME AND ADDRESS OF THE MANUFACTURER

ZHEJIANG HKE RELAY CO., LTD
JIACUN INDUSTRY AREA 28, NINGBO ZHEJIANG 315135

NAME AND ADDRESS OF THE FACTORY

ZHEJIANG HKE RELAY CO., LTD (V002493)
JIACUN INDUSTRY AREA 28, NINGBO ZHEJIANG 315135

NAME, MODEL AND SPECIFICATION

ELECTRICAL RELAY

HRS1系列 触点负载: 1A 120VAC,3A 220VAC; 线圈电压: 3VDC、5VDC、6VDC、9VDC、12VDC、24VDC; 线圈功率: 0.36W,0.2W; 电气寿命: 2E4周期; 机械寿命: 5E4周期; 环境温度: -40℃~70℃ RTII(系列命名方式:HRS1 xyz-S-DCXXV,其中HRS1表示继电器系列号:HRS1,x代表引出端子数,其中空白为6只引出端子,K代表5只引出端子,y代表线圈功率,其中空白为360mW(1A),H为200mW(1A和3A),z代表触点负载,其中空白为1A,120VAC,3为3A 220VAC(4只端子),S代表塑封形式为封胶型,DCXXV表示线圈电压,分别为DC3V,DC5V,DC6V,DC9V,DC12V,DC24V)

THE STANDARDS AND TECHNICAL REQUIREMENTS FOR THE PRODUCTS

GB/T21711.1-2008

CERTIFICATION MODEL

Type Testing of Product + Initial Factory Inspection + Follow up Factory Inspection

This is to certify that the above mentioned products have met the requirements of certification rules CQC11-462155-2010.

Date of issue: Dec.19,2012

Date of expiry: Dec.19,2016

Validity of this certificate is subject to positive result of the regular follow up inspection by issuing certification body until the expiry date.

President:

Wang Kejiao



CHINA QUALITY CERTIFICATION CENTRE

Section 9, No.188, Nansihuan Xilu, Beijing 100070 P.R.China

<http://www.cqc.com.cn>

C 0041434



产品认证证书

证书编号: CQC12002086133

申请人名称及地址

浙江汇港电器有限公司
浙江省宁波市鄞州区云龙镇甲村工业区28号

制造商名称及地址

浙江汇港电器有限公司
浙江省宁波市鄞州区云龙镇甲村工业区28号

生产企业名称及地址

浙江汇港电器有限公司 (V002493)
浙江省宁波市鄞州区云龙镇甲村工业区28号

产品名称和系列、规格、型号

继电器

HRS1系列 触点负载: 1A 120VAC, 3A 220VAC; 线圈电压: 3VDC, 5VDC, 6VDC, 9VDC, 12VDC, 24VDC; 线圈功率: 0.36W, 0.2W; 电气寿命: 2E4周期; 机械寿命: 5E4周期; 环境温度: -40℃~70℃ RTII (系列命名方式: HRS1 xyz -S-DCXXV, 其中HRS1表示继电器系列号; HRS1, x代表引出端子数, 其中空白为6只引出端子, K代表5只引出端子, y代表线圈功率, 其中空白为360mW (1A), H为200mW (1A和3A), z代表触点负载, 其中空白为1A, 120VAC, 3为3A 220VAC (4只端子), S代表塑封形式为封胶型, DCXXV表示线圈电压, 分别为DC3V, DC5V, DC6V, DC9V, DC12V, DC24V)

产品标准和技术要求

GB/T21711.1-2008

认证模式

产品型式试验+初次工厂检查+获证后监督

上述产品符合CQC11-462155-2010认证规则的要求, 特发此证。

发证日期: 2012年12月19日

有效期至: 2016年12月19日

证书有效期内本证书的有效性依据发证机构的定期监督获得保持。

主任: _____



中国质量认证中心

中国·北京·南四环西路188号9区100070

<http://www.cqc.com.cn>

C 0041434

X-ON Electronics

Largest Supplier of Electrical and Electronic Components

Click to view similar products for [General Purpose Relays](#) category:

Click to view products by [Zhejiang](#) manufacturer:

Other Similar products are found below :

[PCN-105D3MH,000](#) [59641F200](#) [5JO-1000CD-SIL](#) [5X827E](#) [5X837F](#) [5X840F](#) [5X842F](#) [5X848E](#) [LY2N-AC120](#) [LY2S-AC220/240](#) [LY2-US-AC120](#) [LY2-US-DC24](#) [LY3-US-AC120](#) [LY4F-UA-DC12](#) [LY4F-UA-DC24](#) [LY4F-US-AC120](#) [LY4F-US-AC240](#) [LY4F-US-DC24](#) [LY4F-VD-AC110](#) [LYQ20DC12](#) [M115C60](#) [M115N010](#) [M115N0150](#) [603-12D](#) [60HE1-5DC](#) [60HE2S-12DC](#) [61211T0B4](#) [61212T400](#) [61222Q400](#) [61243B600](#) [61243C500](#) [61243Q400](#) [61311BOA2](#) [61311BOA6](#) [61311BOA8](#) [61311C0A2](#) [61311COA1](#) [61311COA6](#) [61311F0A2](#) [61311QOA1](#) [61311QOA4](#) [61311T0D6](#) [61311TOA6](#) [61311TOA7](#) [61311TOB3](#) [61311TOB4](#) [61311U0A6](#) [61312Q600](#) [61312T400](#) [61312T600](#)